

I/O Wiring Diagram

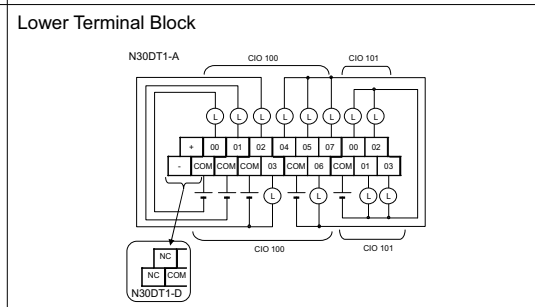

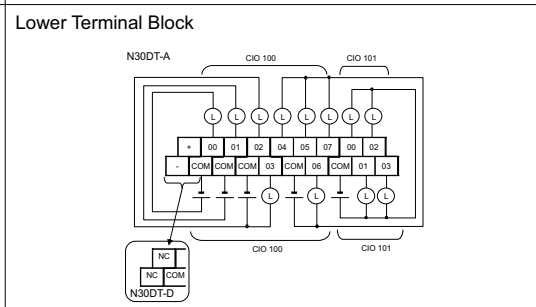
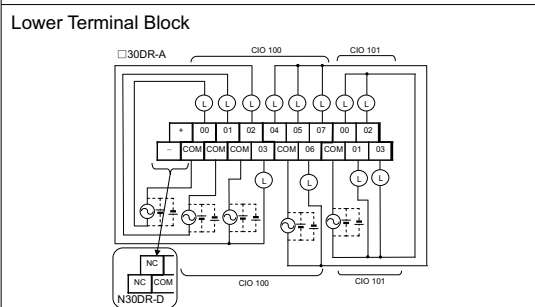
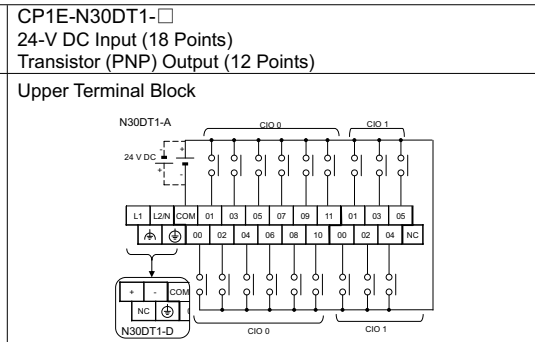
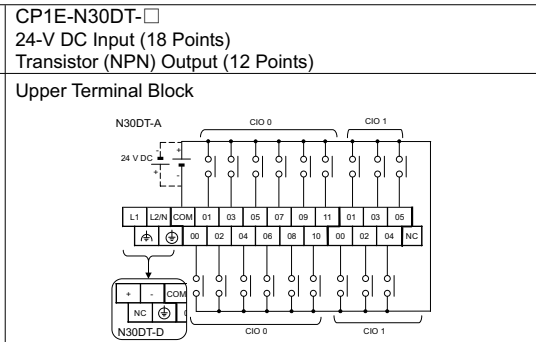
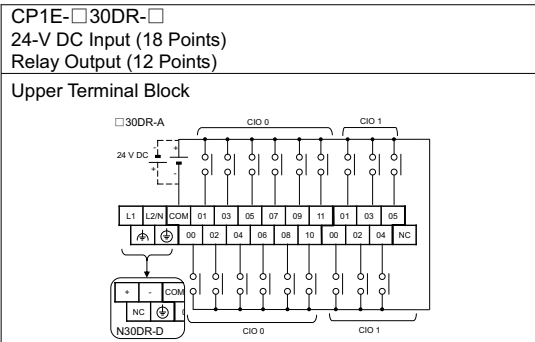
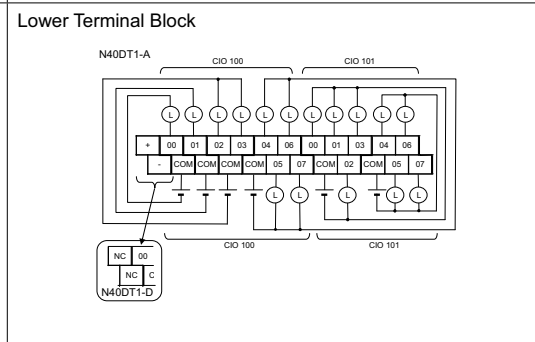
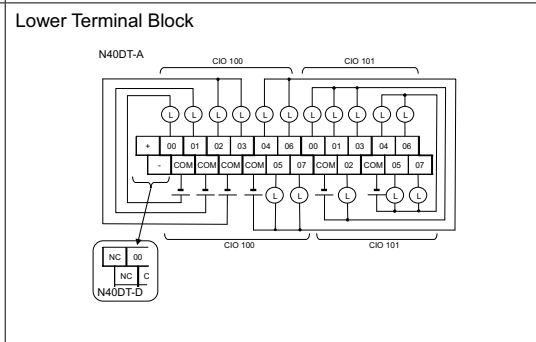
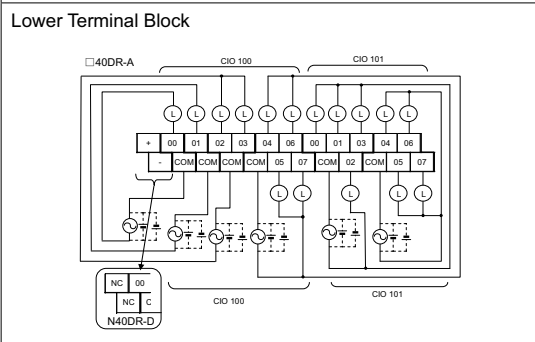
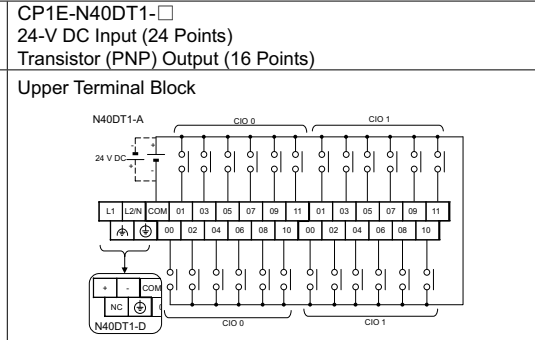
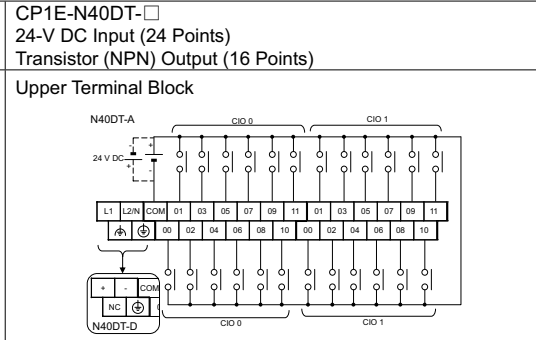
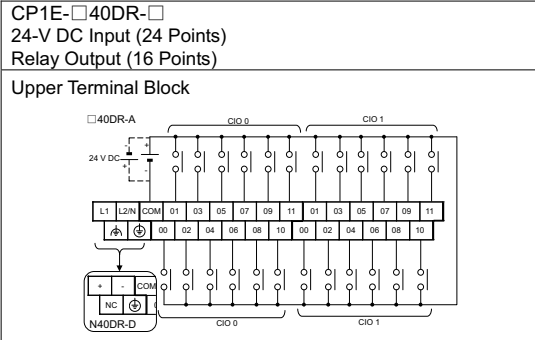
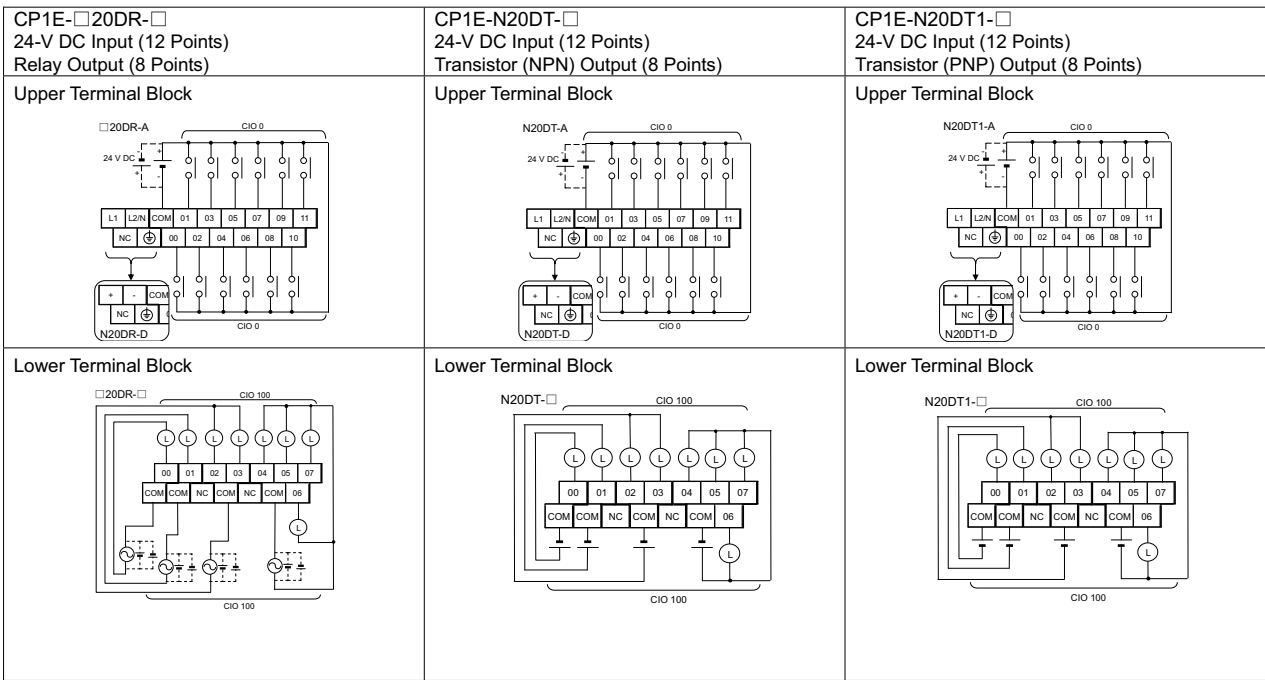

Precautions for Compliance with UL Standards and CSA Standards

Notice to Users of the SYSMAC CP1E CPU Units in the USA and Canada

Please observe the following installation information instead of the general information in the instruction manuals in order to use the product under the certified conditions of UL and CSA when the products are installed in the USA and Canada. These conditions are according to the National Electrical Code in the USA and the Canadian Electrical Code and may vary from information given in the product manuals or safety precautions.

- 24-V DC Power Supply Wiring for Models with DC Power Supply Input
 - Use an isolated DC power supply.
 - Do not use crimp terminals to wire the power supply. Tighten the screw directly on the solid wire.
- I/O Wiring
 - Do not use crimp terminals for I/O wiring. Tighten the screw directly on the solid wire.
 - Do not insert more than one wire in one terminal.
- RS-232C Cable for CP1E built-in RS232C port.
 - Use the recommended cable: XW2Z Series (e.g., XW2Z-200S-CV)
- Surrounding Air Temperature
 - The rated temperature for all other Units is 55°C.

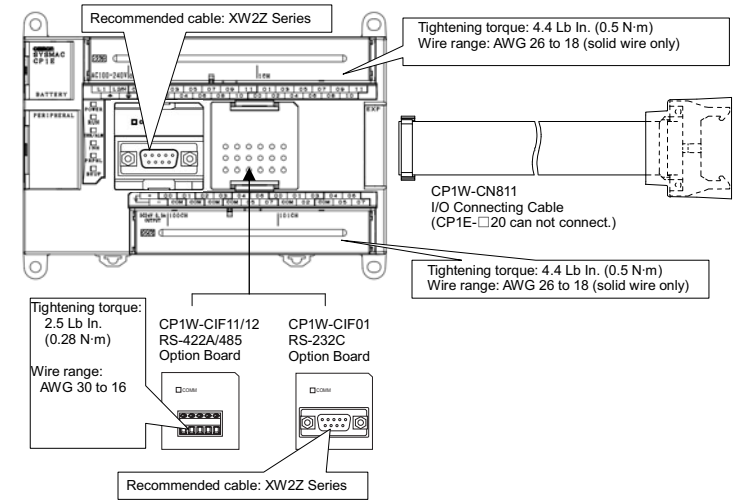

This equipment is suitable for use in Class I, Div. 2, Groups A, B, C, D or Non-Hazardous Locations Only

WARNING – Explosion Hazard – Substitution of Components May Impair Suitability for Class I, Div. 2.

WARNING – Explosion Hazard – Do Not Disconnect Equipment Unless Power Has Been Switched Off Or the Area Is Known To Be Non-Hazardous.