

# **ZS-CRT (CompoNet)**

**Sensor Communications Unit  
for Smart Sensors**

---

**USER'S MANUAL**



# Introduction

The ZS-CRT CompoNet Sensor Communications Unit was developed based on OMRON's advanced control technologies and rich experiences. The ZS-CRT is designed to be used with ZS-series, ZG-series, and ZFV-C-series Smart Sensors.

## Intended Audience

This manual is intended for the following personnel, who must also have knowledge of electrical systems (an electrical engineer or the equivalent) and computers.

- Personnel in charge of introducing FA systems into production facilities
- Personnel in charge of designing FA systems
- Personnel in charge of installing and connecting FA systems
- Personnel in charge of managing FA systems and facilities

## Notice

This manual provides information on using a ZS-CRT Sensor Communications Unit. Be sure to read this manual before attempting to install or use the ZS-CRT, and keep the manual close at hand for reference during operation.

## Trademarks and Copyrights

CompoNet is a registered trademark of the Open DeviceNet Vendors Association. Other product names and company names in this manual are trademarks or registered trademarks of their respective companies.

The copyrights for the ZS-CRT Sensor Communications Unit belong to OMRON Corporation.

## © OMRON, 2007

All rights reserved. No part of this publication may be reproduced, stored in a retrieval system, or transmitted, in any form, or by any means, mechanical, electronic, photocopying, recording, or otherwise, without the prior written permission of OMRON.

No patent liability is assumed with respect to the use of the information contained herein. Moreover, because OMRON is constantly striving to improve its high-quality products, the information contained in this manual is subject to change without notice. Every precaution has been taken in the preparation of this manual. Nevertheless, OMRON assumes no responsibility for errors or omissions. Neither is any liability assumed for damages resulting from the use of the information contained in this publication.



## ***Read and Understand this Manual***

Please read and understand this manual before using the product. Please consult your OMRON representative if you have any questions or comments.

## ***Warranty and Limitations of Liability***

### ***WARRANTY***

OMRON's exclusive warranty is that the products are free from defects in materials and workmanship for a period of one year (or other period if specified) from date of sale by OMRON.

OMRON MAKES NO WARRANTY OR REPRESENTATION, EXPRESS OR IMPLIED, REGARDING NON-INFRINGEMENT, MERCHANTABILITY, OR FITNESS FOR PARTICULAR PURPOSE OF THE PRODUCTS. ANY BUYER OR USER ACKNOWLEDGES THAT THE BUYER OR USER ALONE HAS DETERMINED THAT THE PRODUCTS WILL SUITABLY MEET THE REQUIREMENTS OF THEIR INTENDED USE. OMRON DISCLAIMS ALL OTHER WARRANTIES, EXPRESS OR IMPLIED.

### ***LIMITATIONS OF LIABILITY***

OMRON SHALL NOT BE RESPONSIBLE FOR SPECIAL, INDIRECT, OR CONSEQUENTIAL DAMAGES, LOSS OF PROFITS OR COMMERCIAL LOSS IN ANY WAY CONNECTED WITH THE PRODUCTS, WHETHER SUCH CLAIM IS BASED ON CONTRACT, WARRANTY, NEGLIGENCE, OR STRICT LIABILITY.

In no event shall the responsibility of OMRON for any act exceed the individual price of the product on which liability is asserted.

IN NO EVENT SHALL OMRON BE RESPONSIBLE FOR WARRANTY, REPAIR, OR OTHER CLAIMS REGARDING THE PRODUCTS UNLESS OMRON'S ANALYSIS CONFIRMS THAT THE PRODUCTS WERE PROPERLY HANDLED, STORED, INSTALLED, AND MAINTAINED AND NOT SUBJECT TO CONTAMINATION, ABUSE, MISUSE, OR INAPPROPRIATE MODIFICATION OR REPAIR.

## ***Application Considerations***

### ***SUITABILITY FOR USE***

OMRON shall not be responsible for conformity with any standards, codes, or regulations that apply to the combination of products in the customer's application or use of the products.

At the customer's request, OMRON will provide applicable third party certification documents identifying ratings and limitations of use that apply to the products. This information by itself is not sufficient for a complete determination of the suitability of the products in combination with the end product, machine, system, or other application or use.

The following are some examples of applications for which particular attention must be given. This is not intended to be an exhaustive list of all possible uses of the products, nor is it intended to imply that the uses listed may be suitable for the products:

- Outdoor use, uses involving potential chemical contamination or electrical interference, or conditions or uses not described in this manual.
- Nuclear energy control systems, combustion systems, railroad systems, aviation systems, medical equipment, amusement machines, vehicles, safety equipment, and installations subject to separate industry or government regulations.
- Systems, machines, and equipment that could present a risk to life or property.

Please know and observe all prohibitions of use applicable to the products.

**NEVER USE THE PRODUCTS FOR AN APPLICATION INVOLVING SERIOUS RISK TO LIFE OR PROPERTY WITHOUT ENSURING THAT THE SYSTEM AS A WHOLE HAS BEEN DESIGNED TO ADDRESS THE RISKS, AND THAT THE OMRON PRODUCTS ARE PROPERLY RATED AND INSTALLED FOR THE INTENDED USE WITHIN THE OVERALL EQUIPMENT OR SYSTEM.**

### ***PROGRAMMABLE PRODUCTS***

OMRON shall not be responsible for the user's programming of a programmable product, or any consequence thereof.

## ***Disclaimers***

### ***CHANGE IN SPECIFICATIONS***

Product specifications and accessories may be changed at any time based on improvements and other reasons.

It is our practice to change model numbers when published ratings or features are changed, or when significant construction changes are made. However, some specifications of the products may be changed without any notice. When in doubt, special model numbers may be assigned to fix or establish key specifications for your application on your request. Please consult with your OMRON representative at any time to confirm actual specifications of purchased products.

### ***DIMENSIONS AND WEIGHTS***

Dimensions and weights are nominal and are not to be used for manufacturing purposes, even when tolerances are shown.

### ***PERFORMANCE DATA***

Performance data given in this manual is provided as a guide for the user in determining suitability and does not constitute a warranty. It may represent the result of OMRON's test conditions, and the users must correlate it to actual application requirements. Actual performance is subject to the OMRON Warranty and Limitations of Liability.

### ***ERRORS AND OMISSIONS***

The information in this manual has been carefully checked and is believed to be accurate; however, no responsibility is assumed for clerical, typographical, or proofreading errors, or omissions.

# Safety Precautions

## Safety-related Indications and Their Meanings

The following precautionary indications and symbols are used in this manual to aid in the safe usage of the ZS-CRT Sensor Communications. These precautions contain important safety information. Be sure to observe them carefully.

The indications and symbols used herein, and their meanings, are as listed below.



### **WARNING**

Indicates a potentially hazardous situation which, if not avoided, could result in death or serious injury. Additionally, there may be severe property damage.



### **Caution**

Indicates a potentially hazardous situation which, if not avoided, may result in minor or moderate injury, or property damage.

### **Precautions for Safe Use**

Indicates actions that should be done, or avoided, for the safe use of this product.

### **Precautions for Correct Use**

Indicates actions that should be done, or avoided, to prevent operating failure or malfunction of this product, or to prevent adverse effects on the performance or functions of this product.

### **Note**

Notes within the text of this manual indicate safety-related points and information that are equivalent in importance to those included in the *Precautions for Safe Use* sections.



**WARNING** Be sure to configure the circuits for safety protection such as emergency stop circuits, interlock circuits, and/or limit circuits to the external control circuits so that the whole system operates on the safe side even if an abnormality occurs due to product failure or by external factors. Not doing so will lead to a serious accident due to abnormal operation.



# Precautions for Safe Use

Please observe the following precautions for safe use of the product:

## 1. Installation Environment

- Do not use the product in environments where it can be exposed to flammable or explosive gas.
- Do not install the product close to high-voltage devices and/or power devices in order to secure the safety of operations and maintenance.
- Do not install the product outdoor.

## 2. Power Supply and Wiring

- Do not apply voltage exceeding rated voltage or do not use AC power supply.
- If using dedicated flat cables of each CompoNet system 5 mm or more away from each other without bundling them to avoid operational instability due to interference.
- When performing operations described below, turn OFF the power supplies to the PLC's main unit and slaves, communication devices, and sensors:
  - Assembling the device
  - Setting up a DIP switch or rotary switch
  - Connecting cables or wiring
- Do not connect any network other than CompoNet.
- Do not connect any model other than allowed
- Be sure to use the communication cables and connectors specified for CompoNet.
- Be sure to confirm locking of devices with the locking mechanism such as a communication cable.
- When performing wiring or construction, be careful to avoid metallic particles from entering into the unit.
- When wiring a communication cable, observe the following:
  - Keep the communication cable away from power lines and/or high voltage lines.
  - Do not bend or fold the communication cable.
  - Do not pull the communication cable excessively.
  - Do not put anything on the communication cables.
  - Be sure to keep the communication cables in ducts.
- Check the wiring and switch settings carefully before energizing.
- Keep communication distances and the number of connected devices within the range defined by the CompoNet specifications.

## 3. Others

- Do not disassemble, repair, or modify the product.
- When performing the following operations, confirm that there is no influence on the facilities:
  - Changing PLC operation modes
  - Forced setting/resetting of relay contacts
  - Changing set values on the user program, current values, or PLC operation modes
- Dispose of this product as industrial waste.
- Do not pressurize this product when disposing of it.

# Precautions for Correct Use

Please observe the following precautions to prevent failure to operate, malfunctions, or undesirable effects on product performance.

## 1. Instruction site

Do not install the products in locations subject to the following conditions:

- Direct sunlight or near to heaters appliance
- Ambient temperature outside the rating
- Significant temperature change (with condensation)
- Relative humidity outside the rating
- Presence of corrosive or flammable gasses
- Presence of dust or iron particles
- Direct vibrations or shock to the body
- Direct splay of organic solvent, water or oil, etc.
- Strong magnetic or electric field.

## 2. Maintenance and Inspection

Never use paint thinner, benzine, acetone, or kerosene to clean the product.

Wipe out small dirt or dust carefully using a soft cloth containing a small quantity of alcohol.

# Revision History

A manual revision code appears as a suffix to the catalog number on the front cover of the manual.

<b>Cat. No.</b>	<b>Z277-E1-01</b>
-----------------	-------------------

↑  
Revision Code

Revision code	Date	Revision content
01	January 2008	Original production

---

**Section 1 Overview**

**1**

---

**Section 2 Installation and Connections**

**2**

---

**Section 3 CompoNet Communications Settings**

**3**

---

**Appendix**

**Appendix**

---

# Table of Contents

Introduction .....	v
Intended Audience .....	v
Notice .....	v
Trademarks and Copyrights .....	v
Safety Precautions .....	x
Safety-related Indications and Their Meanings .....	x
Precautions for Safe Use .....	xi
Precautions for Correct Use .....	xii
Revision History .....	xiii
Table of Contents .....	xv
Section 1 Overview .....	1-1
1-1 Features and System Configuration .....	1-2
1-1-1 Overview .....	1-2
1-1-2 Features .....	1-3
1-1-3 System Configuration .....	1-4
Section 2 Specifications and Installation .....	2-1
2-1 Specifications and Dimensions .....	2-2
2-1-1 Specifications .....	2-2
2-1-2 Dimensions .....	2-2
2-2 Installation .....	2-3
2-2-1 Mounting to DIN Track .....	2-3
2-2-2 Ferrite Core Accessories .....	2-3
2-2-3 Connecting to the Sensor Controller .....	2-4
Section 3 CompoNet Communications .....	3-1
3-1 CompoNet Communications Overview .....	3-2
3-1-1 Overview .....	3-2
3-1-2 Example of Using Explicit Message Communications .....	3-4
3-2 Nomenclature .....	3-5
3-2-1 Nomenclature and functions .....	3-5
3-3 CompoNet Wiring .....	3-7
3-4 Operating Procedure .....	3-8
3-4-1 Sensor Communications Unit Operating Procedure .....	3-8
3-5 Remote I/O Communications .....	3-9
3-5-1 Allocating I/O Data in the Master .....	3-9
3-5-2 Remote I/O Communications Using a ZFV-C-series Controller .....	3-14

3-5-3	Setting Monitor Data with the CompoNet Support Software .....	3-15
3-6	Explicit Message Communications.....	3-16
3-6-1	Basic Format of Explicit Messages .....	3-16
3-6-2	Explicit Messages and No-Protocol Commands .....	3-17
3-6-3	GET PARAMETER .....	3-18
3-6-4	SET PARAMETER .....	3-19
3-6-5	EXECUTE MEASUREMENT.....	3-20
3-6-6	GET MEASUREMENT VALUES.....	3-21
3-6-7	GET VERSION .....	3-24
3-6-8	INITIALIZE SETTINGS.....	3-25
3-6-9	SAVE SETTINGS .....	3-26
3-6-10	SWITCH BANK.....	3-27
3-6-11	GET BANK NUMBER.....	3-28
3-6-12	GET PROFILE.....	3-29
3-6-13	GET FLOW DATA .....	3-31
3-6-14	List of Error Codes.....	3-34

Appendix .....	Appendix-1
Appendix 1    CompoNet Device Profile .....	Appendix-2
Appendix 1-1 Device Profile.....	Appendix-2
Appendix 1-2 Object Implementation.....	Appendix-3

# **Section 1**

## **Overview**

# 1-1 Features and System Configuration

## 1-1-1 Overview

The Communications Unit is connected between a Smart Sensor and a PLC or other controller using CompoNet communications. It enables monitoring Sensor measurement values and judgment results, as well as reading and setting parameters, from the controller. (The following Sensor Controllers are compatible: ZS-LDC@@, ZS-MDC@@, ZS-HLDC@@, ZFV-CA@@, and ZG-WDC@@.) The Communications Unit and Sensor Controller are connected with USB.

CompoNet's remote I/O communications can be used to monitor measurement values and judgments without any programming. Explicit message communications can be used to read and set Sensor parameters and to execute measurements.



## 1-1-2 Features

- **Communications Interface That Connects Smart Sensors with a Host,** Including OMRON PLCs (such as the CS Series, CJ Series, and C200HX/HG/HE), As Well As CompoNet-compatible Computers or PLCs from Other Companies

- **Remote I/O Communications Slaves (ZS Series or ZG Series.)**

Remote I/O communications can be used to send Smart Sensors judgments and measurement values (maximum of 4 tasks) can be transmitted to the host PLC (master) without programming.

- **Message Communications**

Commands from the PLC can be used to send measurement triggers and set parameters, such as those for measurement modes and thresholds. Data such as flow data, threshold values, and other parameters can be read.

### 1-1-3 System Configuration

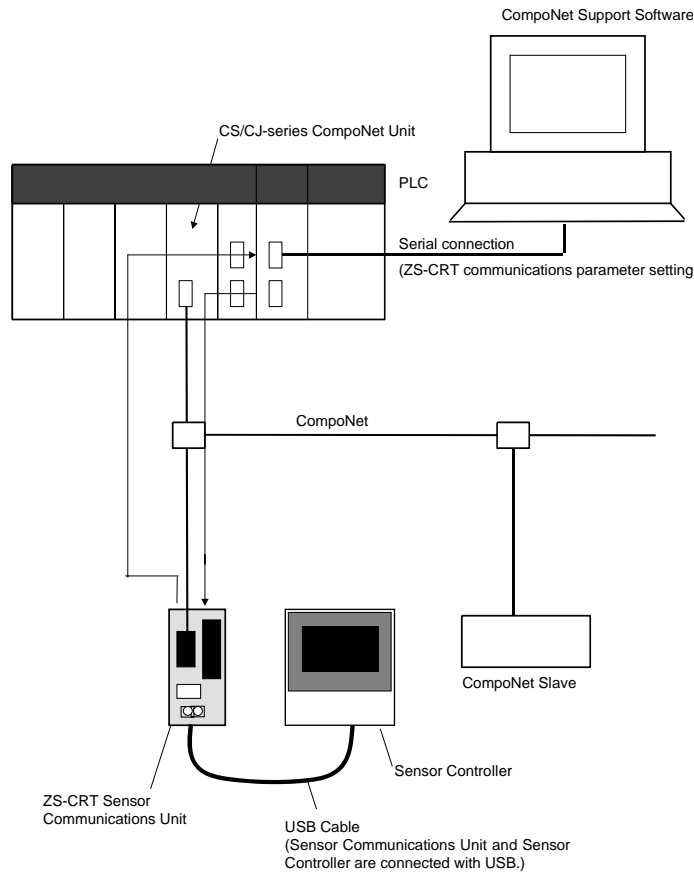

**Note:** The Sensor Communications Unit can be connected only to the Sensor Controller for channel 0. The Sensor Communications Unit will not operate if it is connected to a Sensor Controller for any other channel.

## **Section 2**

---

# **Specifications and Installation**

# 2-1 Specifications and Dimensions

## 2-1-1 Specifications

Item		Specifications		
Connected Sensor		ZS Series	ZG Series	ZFV-C Series
Communi- cations	Remote I/O communi- cations	<ul style="list-style-type: none"> <li>• USB communications status</li> <li>• Judgments</li> <li>• Measurement values</li> </ul>	<ul style="list-style-type: none"> <li>• USB communications status</li> <li>• Judgments</li> <li>• Measurement values</li> </ul>	<ul style="list-style-type: none"> <li>• USB communications status</li> </ul>
	Message communi- cations	<ul style="list-style-type: none"> <li>• Setting and reading Sen- sor parameters</li> <li>• Reading flow data</li> </ul>	<ul style="list-style-type: none"> <li>• Setting and reading Sen- sor parameters</li> <li>• Sending measurement triggers and reading meas- urement values</li> </ul>	<ul style="list-style-type: none"> <li>• Setting and reading Sen- sor parameters</li> <li>• Sending measurement triggers and reading meas- urement values</li> </ul>
Power supply		Supplied from the CompoNet communications connector.		
Sensor Controller connection channel		Can be connected only to channel 0.		
Compatible Sensor Controllers		<ul style="list-style-type: none"> <li>• ZS-LDC@@ (Ver. 2.300 or higher)</li> <li>• ZS-MDC@@ (Ver. 2.200 or higher)</li> <li>• ZS-HLDC@@ (Ver. 1.030 or higher)</li> </ul>	<ul style="list-style-type: none"> <li>• ZG-WDC@@ (Ver. 1.100 or higher)</li> </ul>	<ul style="list-style-type: none"> <li>• ZFV-CA@@ (Ver. 1.300 or higher)</li> </ul>
Power supply voltage		14 to 26.4 V DC		
Current consumption		200 mA max.		
Ambient operating temperature		0 to 50 °C		
Ambient operating humidity		25% to 85%		
Ambient storage temperature		-15 to 60 °C (with no icing or condensation)		
Size (mm)		30 × 58.2 × 98 mm (W × H × D)		
Weight		130 g		

## 2-1-2 Dimensions

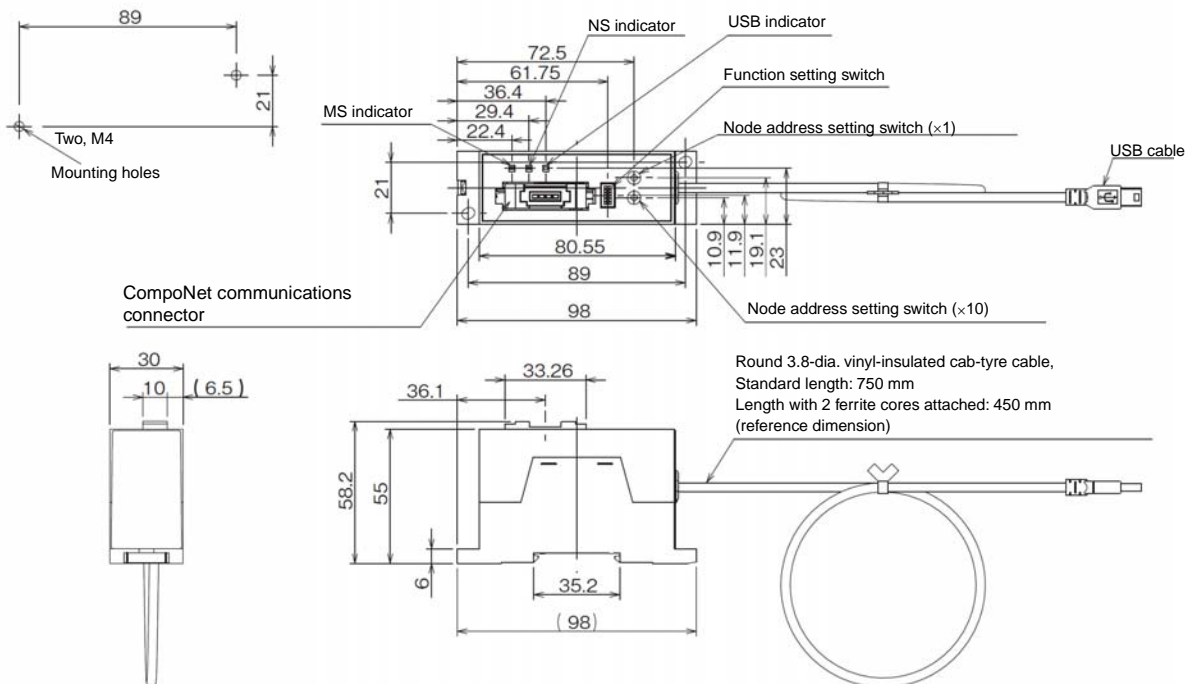

## 2-2 Installation

### 2-2-1 Mounting to DIN Track

1. Insert the hook on the opposite side of the CompoNet connector onto the DIN Track.
2. Press the hook on the CompoNet connector side into the DIN Track.

Do not mount by reversing the order of steps 1 and 2. Doing so could damage the mounting points.

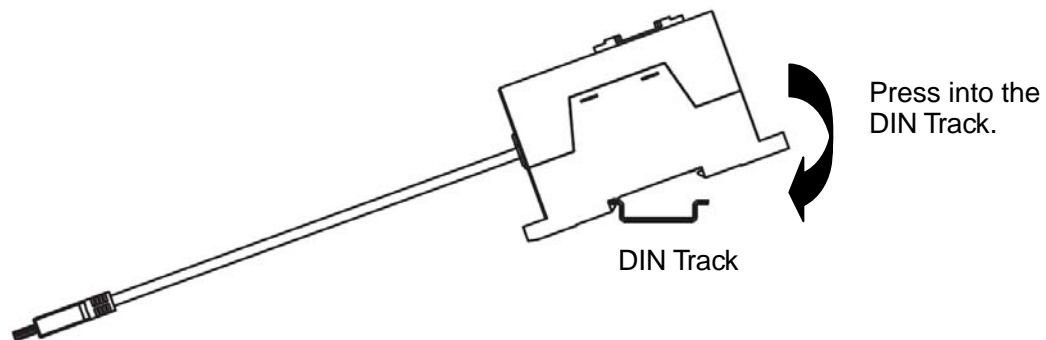

### 2-2-2 Ferrite Core Accessories

Install the enclosed ferrite cores as shown in the following figure. Wrap the cable once around each ferrite core.

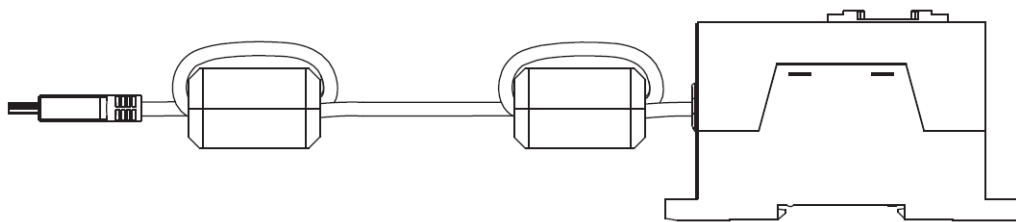

2-2 *Installation*

2-2-3 *Connecting to the Sensor Controller*

**2-2-3 Connecting to the Sensor Controller**

Connect the Unit to the USB connector on the Sensor Controller.

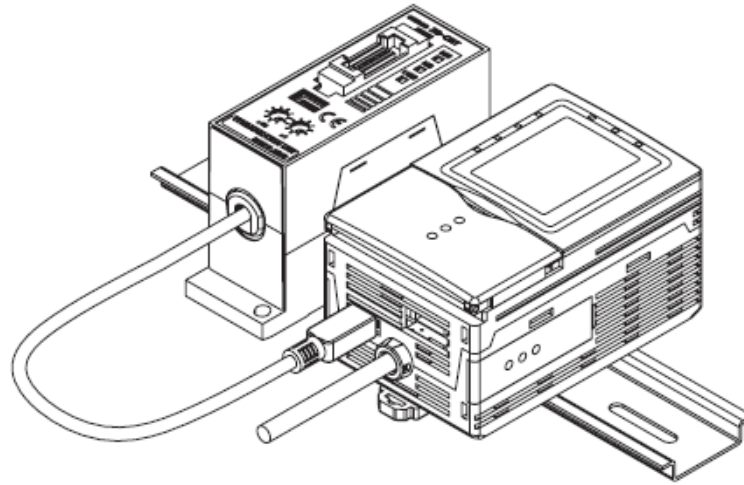

## **Section 3**

---

**CompoNet**

**Communications**

# 3-1 CompoNet Communications Overview

## 3-1-1 Overview

● **Remote I/O Communications (ZS Series and ZG Series)**

The ZS-CRT Communications Unit reads judgments and measurement values from the Smart Sensor and stores them in the Master Input Area.

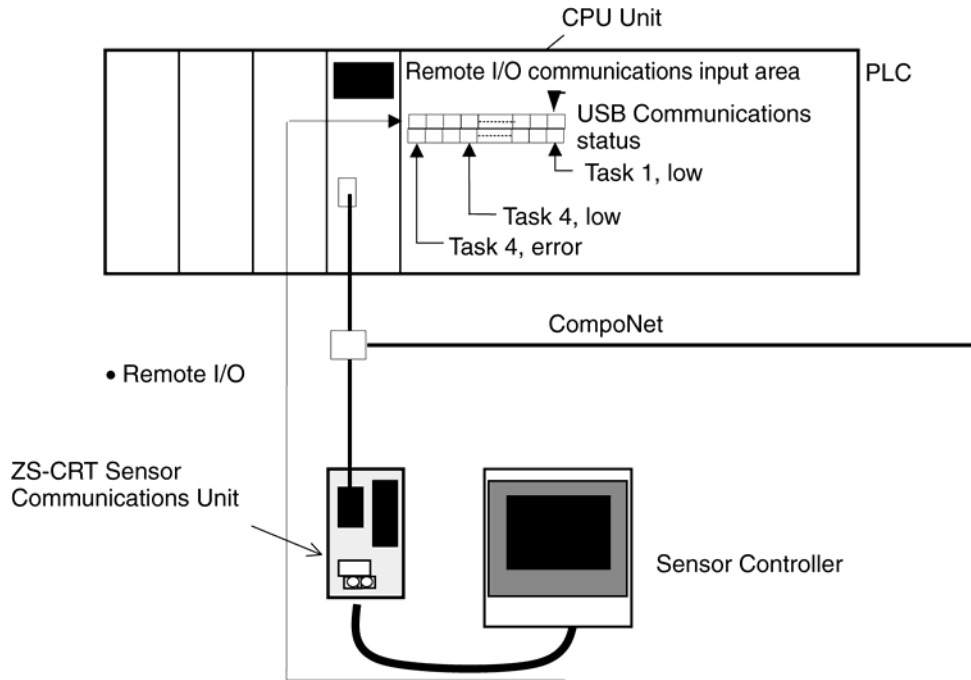

Monitored data	Allocated words	Communications data
Judgments	Input Area: 2 words	<ul style="list-style-type: none"> <li>● Status                             <ul style="list-style-type: none"> <li>● USB communications status between Sensor Communications Unit and Smart Sensor</li> <li>● Monitoring status for each task (monitored or not monitored)</li> </ul> </li> <li>● Judgments                             <ul style="list-style-type: none"> <li>● Judgments for tasks 1 to 4 (HIGH, PASS, LOW, or ERROR)</li> </ul> </li> </ul>
Measurement values	Input Area: 2 words + Number of monitored tasks × 2	<ul style="list-style-type: none"> <li>● Status                             <ul style="list-style-type: none"> <li>● USB communications status between Sensor Communications Unit and Smart Sensor</li> <li>● Monitoring status for each task</li> <li>● Decimal point format and number of decimal places for measurement values</li> </ul> </li> <li>● Measurement Values for Tasks 1 to 4                             <ul style="list-style-type: none"> <li>● Two words are used for the measurement value for one task.</li> </ul> </li> </ul>



Judgments + Measurement values	Input Area 2 words + Number of monitored tasks × 2	<ul style="list-style-type: none"> <li>● Status                     <ul style="list-style-type: none"> <li>● USB communications status between Sensor Communications Unit and Smart Sensor</li> <li>● Monitoring status for each task (monitored or not monitored)</li> <li>● Decimal point format and number of decimal places for measurement values</li> </ul> </li> <li>● Judgments                     <ul style="list-style-type: none"> <li>● Judgments for tasks 1 to 4 (HIGH, PASS, LOW, or ERROR)</li> </ul> </li> <li>● Measurement Values for Tasks 1 to 4                     <ul style="list-style-type: none"> <li>● Two words are used for the measurement value for one task.</li> </ul> </li> </ul>
--------------------------------	---	---

● **Explicit Message Communications**

The Sensor Communications Unit sends explicit message commands to read and write parameters in the connected Sensor Controller.

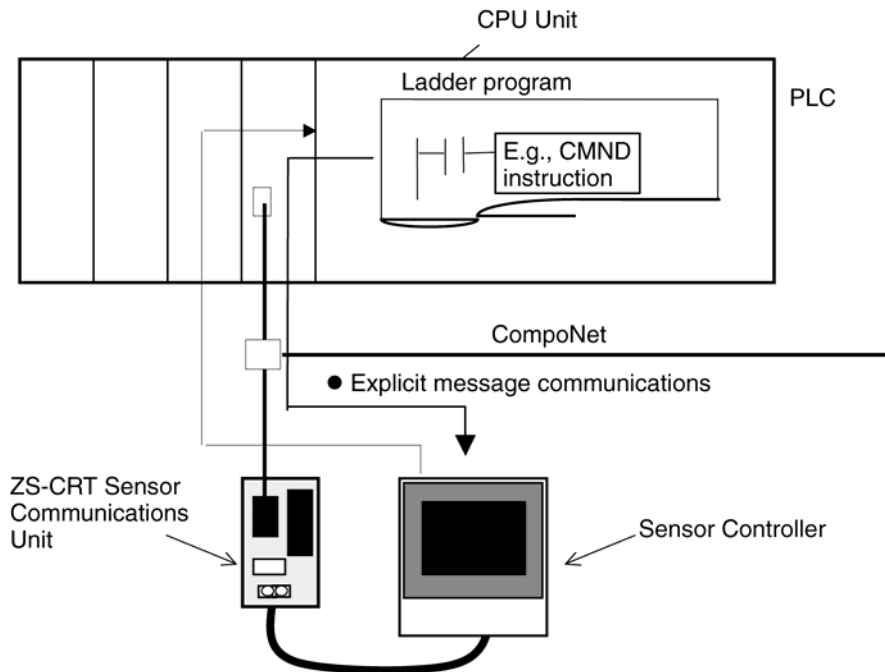

Command	Description	Applicable Sensors
GET PARAMETER	Reads the set value of Sensor Controller parameters.	ZS, ZG, ZFV-C
SET PARAMETER	Changes the set value of Sensor Controller parameters.	ZS, ZG, ZFV-C
EXECUTE MEASUREMENT	Sends measurement triggers.	ZG, ZFV-C
GET MEASUREMENT VALUES	Reads current measurement values.	ZS, ZG, ZFV-C
GET VERSION	Reads the Sensor Controller version.	ZS, ZG, ZFV-C
INITIALIZE SETTINGS	Returns all Sensor Controller data to the default settings.	ZG, ZFV-C
SAVE SETTINGS	Saves all bank data to flash memory in the Sensor Controller.	ZS, ZG, ZFV-C
SWITCH BANK	Switches the current bank.	ZS, ZG, ZFV-C
GET BANK NUMBER	Reads the current bank number.	ZS, ZG, ZFV-C
GET PROFILE	Reads the profile.	ZG
GET FLOW DATA	Reads flow data.	ZS

### 3-1-2 Example of Using Explicit Message Communications

Example: Saving Setting Data from the Sensor Controller

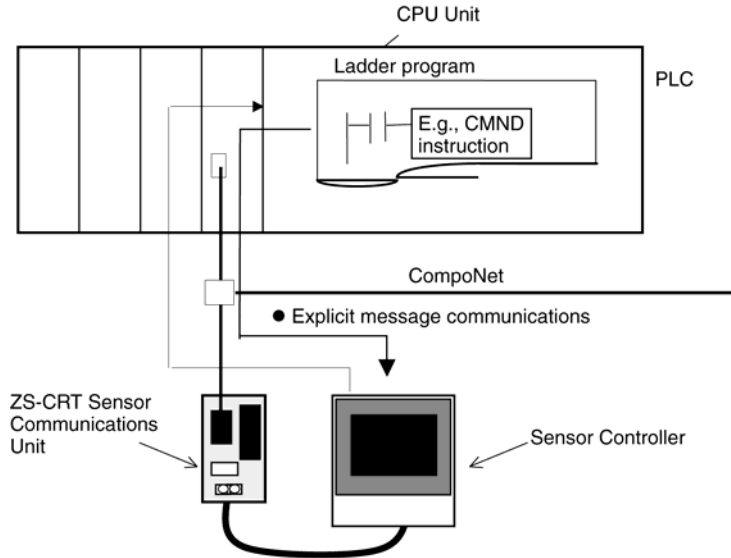

• **Command Format for SAVE SETTING DATA:**

The following explicit message is sent.

Destination node address	Service code	Class ID	Instance ID	Attribute ID	Data
1000 hex	0054 hex	00A1 hex	0000 hex	---	---

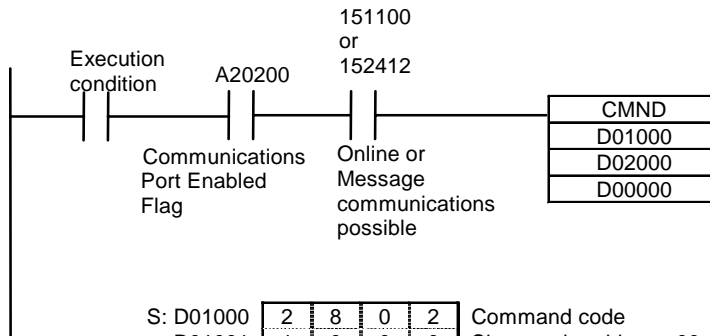

Sends 10 bytes of command data from D01000 to destination node with node address 05, and stores 10 bytes of response data in D02000 onwards at the local node. (D00000: Control data)

S: D01000	2	8	0	2	Command code
D01001	1	0	0	0	Slave node address: 00
D01002	0	0	5	4	Service code: 0052 hex
D01003	0	0	A	1	Class ID: 00A1 hex
D01004	0	0	0	0	Instance ID: 0000 hex (unit number)

D: D02000 [ ] First response word

C: D00000	0	0	0	A	Number of command data bytes: 10
D00001	0	0	0	A	Number of response data bytes: 10
D00002	0	0	0	0	Destination network address: 0
D00003	0	0	2	0	Destination Sensor Communications Unit node address: 00 hex
					Destination unit address: 20 hex
D00004	0	0	0	0	Response: Required, Communications port No.: 0, Number of retries: 0 hex
D00005	0	1	2	C	Response monitoring time: 30 s

## 3-2 Nomenclature

### 3-2-1 Nomenclature and functions

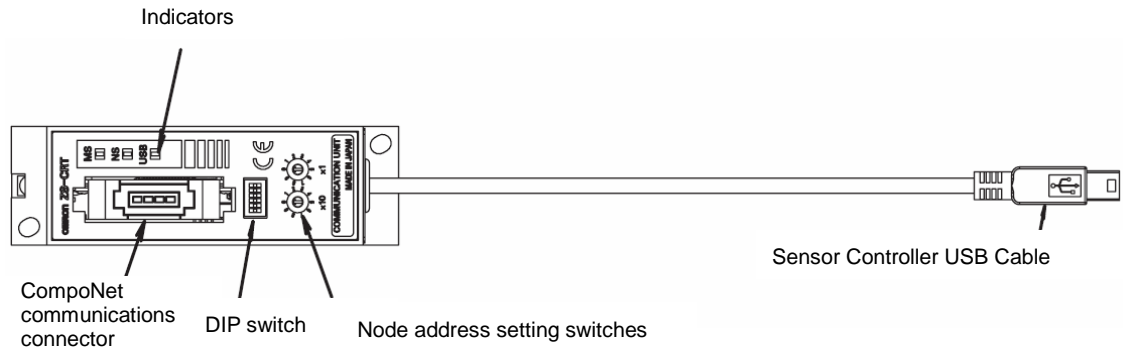

#### ■ LED Indicators

The meanings of the indicators are as given in the following table.

Indicator	Name	Color	Status	Status definition	Meaning
MS	Module status	Green	Lit	Normal status	Unit operating normally.
			Lit	Fatal error	Unit hardware error. Watchdog timer has timed-out.
		Red	Flash-ing	Non-fatal error	Setting error.
			–	Not lit	Power turned OFF
NS	Network status	Green	Lit	Online and participating	Communications are operating normally and node is participating in the network.
			Flash-ing	Online but not participating	Communications operating normally and preparations to participate in the network are in progress.
		Red	Lit	Fatal communications error	Duplication address setting error.
			Flash-ing	Non-fatal communications error	Communications timeout.
		–	Not lit	Power turned OFF/initializing	Power turned OFF or initializing.
			USB	Green	Lit
Flash-ing	Sensor communications in progress	USB communications operating normally and message communications are being executed.			
Red	Lit	Sensor communications error		EEPROM checksum error or USB communications error. (See note.)	
	Flash-ing	Sensor communications error/Sensor not connected		USB communications error (see note) or USB cable not connected.	
–	Not lit	Power turned OFF A non-supported Sensor Controller is connected.		Connect a Sensor Controller that is not supported.	

**Note:** The indicator stays lit or flashes from the time that the power is turned ON until initializing the Sensor Controller has been completed and communications are possible.

## 3-2 Nomenclature

### 3-2-1 Nomenclature and functions

#### ● Indicator Status during Normal Operation

MS	Normal when lit green.
NS	Normal (online with communications established) when lit green.
USB	Normal when lit green indicating I/O communications are in progress, or flashing green indicating message communications are in progress.

#### ■ Switches

##### ● Node address setting Switches

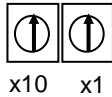

The rotary switches are used to set the CompoNet node address. The left rotary switch sets the ten's digit, and the right rotary switch sets the one's digit. Set the Unit's CompoNet node address to between 00 and 63. The switch settings are read when the power is turned ON.

##### ● DIP Switch for Setting Functions

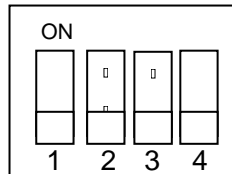

Turn OFF all pins.

#### ■ CompoNet Communications Connector

The CompoNet communications cable is connected. Either a Flat Connector Plug or Open Type Connector (DCN4-TB4) can be connected to the CompoNet communications connector.

#### ■ Sensor Controller Cable

The Sensor Controller cable is used for communications with the Sensor Controller. Connect the Sensor Controller using the USB port on the Sensor Controller.

## 3-3 CompoNet Wiring

Attach the connector to the CompoNet communications cable, and then connect the connector to the CompoNet connector on the Sensor Communications Unit.

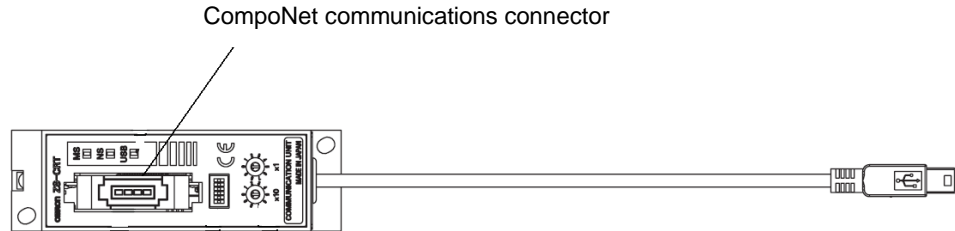

Refer to the following manuals for information on CompoNet communications cables, connector models, and installation methods.

- CRT1 CompoNet Slave Units and Repeater Unit OPERATION MANUAL (Cat. No. W457)
- CS1W-CRM21/CJ1W-CRM21 CompoNet Master Units OPERATION MANUAL (Cat. No. W456)

# 3-4 Operating Procedure

## 3-4-1 Sensor Communications Unit Operating Procedure

Step	Item	Description	
1	Mount Sensor Communications Unit to DIN Track.	Mount the Sensor Communications Unit to the DIN Track. Connect the Sensor Controller after mounting the Unit to the DIN Track.	
2	Install the ferrite cores on the Sensor Controller cable.	Install the ferrite cores on the Sensor Controller cable.	
3	Connect the Sensor Controller to the Sensor Communications Unit.	Connect the USB connector on the Sensor Controller cable to the USB port on the Sensor Controller.	
4	Connect a CompoNet communications cable to the CompoNet communications connector.	Connect a CompoNet communications cable to the CompoNet communications connector.	
5	Set the CompoNet Node address to between 0 and 63.	Set the CompoNet Node address to between 0 and 63.	
6	Set the DIP switch.	Confirm that all pins are set to OFF.	
7	Start the Sensor Controller.	Turn ON the power to the Sensor Controller.	
8	Set Sensor Controller USB communications.	When connecting a ZS-series Sensor Controller, set the Controller communications setting to non-procedural communications. (The Sensor Communications Unit and Sensor Controller cannot communicate unless non-procedural communications is set.)	
9	Turn ON the DC power supply.	The Sensor Communications Unit is powered through the CompoNet connector.	
8	Check the indicators.	MS	Normal when lit green.
		NS	Normal (online with communications established) when lit green.
		USB	Sensor communications in progress when lit green.
9	Start communications.	Remote I/O communications	Enable the scan list in the Master, and set the PLC to RUN mode.
		Explicit message communications	Send explicit messages from the Master.

**Note:** Use the connected Sensor Controller in RUN mode. Communications are not possible in modes other than RUN mode. Also, do not use the controls on the Sensor Controller for operation when the Sensor Controller is connected to the Sensor Communications Unit.

## 3-5 Remote I/O Communications

### 3-5-1 Allocating I/O Data in the Master Unit

When using a ZS-series or ZG-series Sensor Controller, the Sensor Communications Unit can monitor Sensor judgments and measurement values by using CompoNet remote I/O communications. When using a ZFV-C-series Sensor Controller, only the USB communications status can be monitored by using remote I/O communications.

Words in the Input Area in the CompoNet Master are allocated to the monitor data sent from the Sensor Communications Unit.

The following three types of monitor data can be selected with the Sensor Communications Unit settings. (The data and tasks to be monitored are selected from the CompoNet Support Software.)

Monitored data	Allocated words	Communications data
Judgments	Input Area: 2 words	<ul style="list-style-type: none"> <li>● Status                             <ul style="list-style-type: none"> <li>● USB communications status between Sensor Communications Unit and Smart Sensor</li> <li>● Monitoring status for each task (monitored or not monitored)</li> </ul> </li> <li>● Judgments                             <ul style="list-style-type: none"> <li>● Judgments for tasks 1 to 4 (HIGH, PASS, LOW, or ERROR)</li> </ul> </li> </ul>
Measurement values	Input Area: 2 words + Number of monitored tasks × 2	<ul style="list-style-type: none"> <li>● Status                             <ul style="list-style-type: none"> <li>● USB communications status between Sensor Communications Unit and Smart Sensor</li> <li>● Monitoring status for each task</li> <li>● Decimal point format and number of decimal places for measurement values</li> </ul> </li> <li>● Measurement Values for Tasks 1 to 4                             <ul style="list-style-type: none"> <li>● Two words are used for the measurement value for one task.</li> </ul> </li> </ul>
Judgments + Measurement values	Input Area 2 words + Number of monitored tasks × 2	<ul style="list-style-type: none"> <li>● Status                             <ul style="list-style-type: none"> <li>● USB communications status between Sensor Communications Unit and Smart Sensor</li> <li>● Monitoring status for each task (monitored or not monitored)</li> <li>● Decimal point format and number of decimal places for measurement values</li> </ul> </li> <li>● Judgments                             <ul style="list-style-type: none"> <li>● Judgments for tasks 1 to 4 (HIGH, PASS, LOW, or ERROR)</li> </ul> </li> <li>● Measurement Values for Tasks 1 to 4                             <ul style="list-style-type: none"> <li>● Two words are used for the measurement value for one task.</li> </ul> </li> </ul>

**Note 1:** When using measurement triggers with a ZG-series Sensor Controller, check the status of the GATE signal and refer to the measurement result after the measurement is triggered. An error value (–999.999) will be returned during trigger measurement.

**Note 2:** When using measurement triggers with a ZG-series Sensor Controller, set the output response time to 30 s max. If the output response time is longer than 30 s, a communications error will be generated between the Sensor Communications Unit and the Sensor Controller. (Output response time = Measurement cycles × Average number of measurements)

**Note 3:** When switching banks on the Sensor Controller, make sure that the switching operation is made through the Sensor Communications Unit. If banks are switched by using a bank input line, a communications error will be generated in the Sensor Communications Unit.

### ■ Monitored Data: Judgments

Two words are allocated.

Word m: Status

Bit	Description
00	USB communications status
01	USB communications error
02	Judgment status
03	Measurement value status
04	Task 1 status
05	Task 2 status
06	Task 3 status
07	Task 4 status

Bit	Description
08	Decimal format
09 to 11	Number of decimal places
12	Reserved
13	Reserved
14	Reserved
15	Reserved

Word m + 1: Judgments

Bit	Description
00	Task 1, low
01	Task 1, pass
02	Task 1, high
03	Task 1, error
04	Task 2, low
05	Task 2, pass
06	Task 2, high
07	Task 2, error

Bit	Description
08	Task 3, low
09	Task 3, pass
10	Task 3, high
11	Task 3, error
12	Task 4, low
13	Task 4, pass
14	Task 4, high
15	Task 4, error

#### ● Status

- **USB Communications Status:**  
Turns ON when communications with the Sensor Controller have been established and correct I/O data is sent.
- **USB Communications Error:**  
Turns ON when communications with the Sensor Controller are not normal.
- **Judgment Status:**  
Turns ON when the judgment for either of tasks 1 to 4 is being monitored.
- **Measurement Value Status:**  
OFF.
- **Task 1 to 4 Status:**  
Turns ON when monitoring the judgment of the corresponding tasks.
- **Decimal Format:**  
Indicates the measurement value decimal format (1: Fixed decimal point, 0: Floating decimal point).
- **Number of Decimal Places**  
The number of decimal digits (1 to 5) when using the fixed decimal point format. Bit 9 is the rightmost digit, and bit 11 is the leftmost digit. For example, if there are 3 decimal digits, bit 9 and bit 10 will be set to 1, and bit 11 will be set to 0.

#### ● Judgments

Judgment for each task. The bit corresponding to each task is turned ON or OFF according to its judgment.



■ **Monitored Data: Measurement Values**

Four to ten words are allocated.

(The number of allocated words depends on the number of tasks for which the measurement value is being monitored.)

Word m: Status

Bit	Description
00	USB communications status
01	USB communications error
02	Judgment status
03	Measurement value status
04	Task 1 status
05	Task 2 status
06	Task 3 status
07	Task 4 status

Bit	Description
08	Decimal format
09 to 11	Number of decimal places
12	Reserved
13	Reserved
14	Reserved
15	Reserved

Word m + 1: Not used.

Words m + 2 to m + 9 (max.): Measurement Values

	15	14	13	12	11	10	09	08	07	06	05	04	03	02	01	00
m + 2	Task 1 measurement value, rightmost bytes															
m + 3	Task 1 measurement value, leftmost bytes															
:	:															
:	:															
m + 8	Task 4 measurement value, rightmost bytes															
m + 9	Task 4 measurement value, leftmost bytes															

● **Status**

- **USB Communications Status:**  
 Turns ON when communications with the Sensor Controller have been established and correct I/O data is sent.
- **USB Communications Error:**  
 Turns ON when communications with the Sensor Controller are not normal.
- **Judgment Status:**  
 OFF.
- **Measurement Value Status:**  
 Turns ON when the measurement value for either of tasks 1 to 4 is being monitored.
- **Task 1 to 4 Status:**  
 Turns ON when monitoring the measurement value of the corresponding task.
- **Decimal Format:**  
 Indicates the measurement value decimal format (1: Fixed decimal point, 0: Floating decimal point).

3-5 Remote I/O Communications  
 3-5-1 Allocating I/O Data in the Master Unit

- **Number of Decimal Places**  
 The number of decimal digits (1 to 5) when using the fixed decimal point format. Bit 9 is the rightmost digit, and bit 11 is the leftmost digit. For example, if there are 3 decimal digits, bit 9 and bit 10 will be set to 1, and bit 11 will be set to 0.

• **Measurement Values**

The measurement value for each task.  
 The tasks for which measurement values are to be monitored are set from the CompoNet Support Software. To monitor the measurement values of only specified tasks, the measurement values of only the specified task are returned starting from the beginning words.

Example: Monitoring Only Task 2

	15	14	13	12	11	10	09	08	07	06	05	04	03	02	01	00
m + 2	Task 2 measurement value, rightmost bytes															
m + 3	Task 2 measurement value, leftmost bytes															

■ **Monitored Data: Judgments + Measurement Values**

Four to ten words are allocated.  
 (The number of allocated words depends on the number of tasks for which the measurement value is being monitored.)

Word m: Status

Bit	Description	Bit	Description
00	USB communications status	08	Decimal format
01	USB communications error	09 to 11	Number of decimal places
02	Judgment status	12	Reserved
03	Measurement value status	13	Reserved
04	Task 1 status	14	Reserved
05	Task 2 status	15	Reserved
06	Task 3 status		
07	Task 4 status		

Word m + 1: Judgment

Bit	Description	Bit	Description
00	Task 1, low	08	Task 3, low
01	Task 1, pass	09	Task 3, pass
02	Task 1, high	10	Task 3, high
03	Task 1, error	11	Task 3, error
04	Task 2, low	12	Task 4, low
05	Task 2, pass	13	Task 4, pass
06	Task 2, high	14	Task 4, high
07	Task 2, error	15	Task 4, error

Word m + 2 to m + 9 (max.): Measurement Values

	15	14	13	12	11	10	09	08	07	06	05	04	03	02	01	00
m + 2	Task 1 measurement value, rightmost bytes															
m + 3	Task 1 measurement value, leftmost bytes															
:	:															
:	:															
m + 8	Task 4 measurement value, rightmost bytes															
m + 9	Task 4 measurement value, leftmost bytes															

● **Status**

- **USB Communications Status:**  
 Turns ON when communications with the Sensor Controller have been established and correct I/O data is sent.
- **USB Communications Error:**  
 Turns ON when communications with the Sensor Controller are not normal.
- **Judgment Status:**  
 Turns ON when the judgment for either of tasks 1 to 4 is being monitored.
- **Measurement Value Status:**  
 Turns ON when the measurement value for either of tasks 1 to 4 is being monitored.
- **Task 1 to 4 Status:**  
 Turns ON when monitoring the measurement value or the judgment of the corresponding task.
- **Decimal Format:**  
 Measurement value decimal format (1: Fixed decimal point, 0: Floating decimal point).
- **Number of Decimal Places**  
 The number of decimal digits (1 to 5) when using the fixed decimal point format. Bit 9 is the rightmost digit, and bit 11 is the leftmost digit. For example, if there are 3 decimal digits, bit 9 and bit 10 will be set to 1, and bit 11 will be set to 0.

● **Judgments**

The judgment for each task. The bit corresponding to each task is turned ON or OFF according to its judgment.

● **Measurement Values**

The measurement value for each task.

The tasks for which measurement values are to be monitored are set from the CompoNet Support Software. To monitor the measurement values of only specified tasks, the measurement values of only the specified task are returned starting from the beginning words.

Example: Monitoring Only Tasks 2 and 4

	15	14	13	12	11	10	09	08	07	06	05	04	03	02	01	00
m + 2	Task 2 measurement value, rightmost bytes															
m + 3	Task 2 measurement value, leftmost bytes															
m + 4	Task 4 measurement value, rightmost bytes															
m + 5	Task 4 measurement value, leftmost bytes															

### 3-5-2 Remote I/O Communications Using a ZFV-C-series Controller

When using a ZFV-C-series Controller, only the USB communications status will be sent when using CompoNet remote I/O communications.

Word m: Status

Bit	Description
00	USB communications status
01	USB communications error
02	-
03	-
04	-
05	-
06	-
07	-

Bit	Description
08	-
09	-
10	-
11	-
12	-
13	-
14	-
15	-

### 3-5-3 Setting Monitor Data with the CompoNet Support Software

- The data and tasks to be monitored are set from the CompoNet Support Software. Refer to the *CRT1-series CompoNet Slave Units and Repeater Unit Operation Manual* (Cat. No. W457) for information on general operating procedures for the CompoNet Support Software.

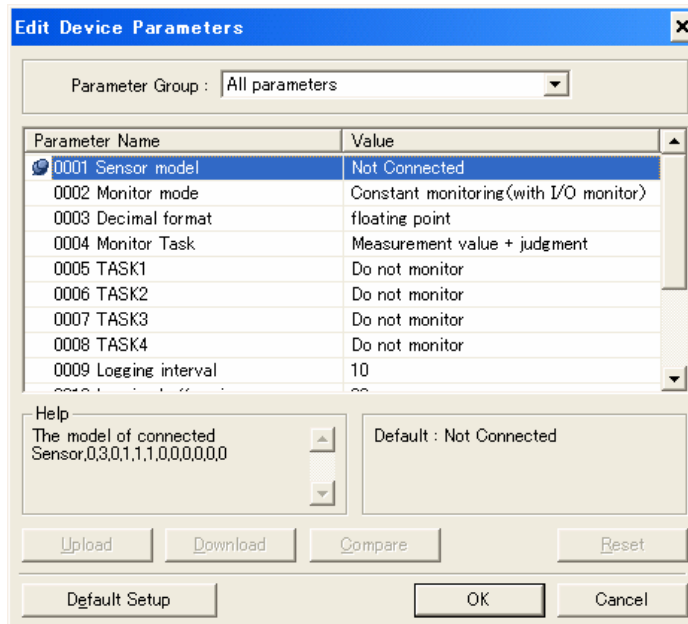

In the CompoNet Support Software, select the Sensor Communications Unit icon to display the setup dialog box shown above. The data and tasks to be monitored are set in this dialog box.

Setting	Description
Sensor model	The model of the connected Sensor will be displayed. This item cannot be selected only for the monitor.
Monitor mode	<ul style="list-style-type: none"> <li>• <b>Constant monitoring (with I/O monitor)</b> Select when not using data logging.</li> <li>• Data logging (without I/O monitor) Select when using data logging with the Sensor Communications Unit. When data logging is selected, I/O monitoring will not be performed.</li> </ul>
Decimal format (Only for the ZG)	<ul style="list-style-type: none"> <li>• Floating decimal point Select to display floating decimal point.</li> <li>• <b>Fixed decimal point</b> Select to display a fixed decimal point.</li> </ul>
Monitored data	<ul style="list-style-type: none"> <li>• Measurement values Select to monitor the measurement value.</li> <li>• Judgment Select to monitor the judgment.</li> <li>• <b>Measurement + judgment</b> Select to monitor the measurement value and judgment.</li> </ul>
Task 1 to Task 4	<ul style="list-style-type: none"> <li>• <b>Monitor</b> Select to monitor the corresponding task.</li> <li>• Do not monitor Select to not monitor the corresponding task.</li> </ul>

The items in bold font are the default settings. After setting the items to be monitored, download the necessary parameters to the Sensor Communications Unit.

## 3-6 Explicit Message Communications

Explicit messages can be sent from the Master to the Sensor Communications Unit to read or write any parameters. The Sensor Communications Unit processes the command sent from the Master and then return a response.

### 3-6-1 Basic Format of Explicit Messages

The basic format of commands and responses is shown below.

#### ● Command Format

Destination node address	Service code	Class ID	Instance ID	Data
-----------------------------	-----------------	-------------	----------------	------

##### Destination Node Address

The node address of the Unit that is sending the explicit message (command) is specified as a 2-byte hexadecimal number.

**Note: When using an OMRON CompoNet Master Unit, the leftmost byte of the destination node address of the Sensor Communications Unit is 10 hex.**

For example, when sending to node address 02, the destination node address is 1002 hex.

##### Service Code, Class ID, Instance ID, Data

These parameters are used to specify the command, object to process, and processing content.

**Note: The number of bytes designated for the class ID, instance ID, and attribute ID depend on the Master Unit. When sent from an OMRON CompoNet Master Unit, the class ID and instance ID are 2 bytes (4 digits).**

#### ● Response Format

##### • Normal Response

Number of bytes received	Source node address	Service code	Data
-----------------------------	------------------------	--------------	------

##### • Error Response

Number of bytes received 0004 hex (fixed)	Source node address	Service code	Error code
--	------------------------	--------------	------------

##### Number of Bytes Received

The number of bytes received from the source node address is returned in hexadecimal. When an error response is returned for an explicit message, the number of bytes is always 0004 hex.

##### Source Node Address

The node address of the node from which the command was sent is returned in hexadecimal.

**Note:** When using an OMRON CompoNet Master Unit, the leftmost byte of the destination node address returned by the Sensor Communications Unit is 10 hex.

**Service Codes**

For normal completion, the leftmost bit of the service code specified in the command is turned ON and the result is stored in the response as shown in the following table.

Command service code	Response service code
004C hex	00CC hex
004D hex	00CD hex
0050 hex	00D0 hex
0051 hex	00D1 hex
0052 hex	00D2 hex
0053 hex	00D3 hex
0054 hex	00D4 hex
0055 hex	00D5 hex
0056 hex	00D6 hex
0057 hex	00D7 hex
0058 hex	00D8 hex

When an error response is returned for an explicit message, the service code is always 0094 hex.

**Data**

Read data is included only when a read command is executed.

**Error Code**

The explicit message error code. For details, refer to the 3-6-14 *List of Error Codes* on page 3-34.

**3-6-2 Explicit Messages and No-Protocol Commands**

The Sensor Communications Unit converts received explicit messages into no-protocol commands and sends them to the Sensor Controller.

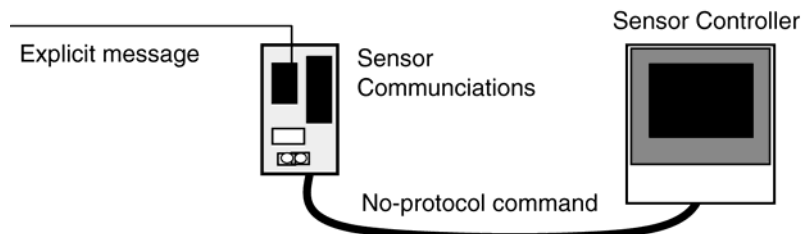

For details regarding no-protocol commands, refer to the no-protocol communications command reference or user's manual.

### 3-6-3 GET PARAMETER

The Get Parameter command reads Sensor Controller parameters.

Applicable Sensors	No-protocol command
ZS, ZG, ZFV-C	"DATAGET"

● **Command Format**

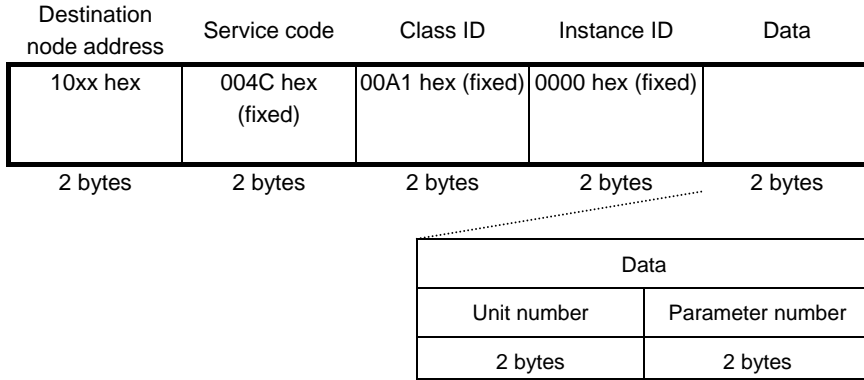

**Note:** When using a ZS-series Sensor Controller, the data number will be set instead of the parameter number.

● **Response Format**

- **Normal Response**

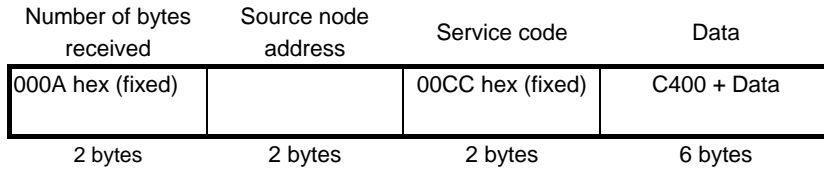

- **Error Response**

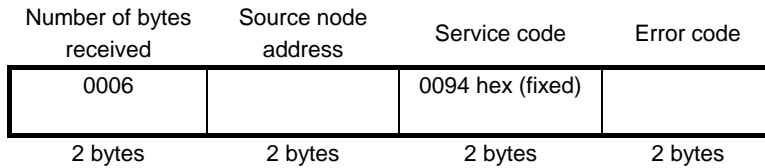



### 3-6-4 SET PARAMETER

The Set Parameter command changes the set values of Sensor Controller parameters.

Applicable Sensors	No-protocol command
ZS, ZG, ZFV-C	"DATASET"

#### ● Command Format

Destination node address	Service code	Class ID	Instance ID	Data
10xx hex	004D hex (fixed)	00A1 hex (fixed)	0000 hex (fixed)	
2 bytes	2 bytes	2 bytes	2 bytes	8 bytes

Data			
Unit number	Parameter number	C400 hex (fixed)	Set value
1 byte	1 byte	2 bytes	4 bytes

**Note:** When using a ZS-series Sensor Controller the data number will be set instead of the parameter number.

#### ● Response Format

##### · Normal Response

Number of bytes received	Source node address	Service code
0004		00CD hex (fixed)
2 bytes	2 bytes	2 bytes

##### · Error Response

Number of bytes received	Source node address	Service code	Error code
0006		0094 hex (fixed)	
2 bytes	2 bytes	2 bytes	2 bytes

**3-6-5 EXECUTE MEASUREMENT**

Sends a measurement trigger.

Applicable Sensors	No-protocol command
ZG	"TRIG"
ZFV-C	"MEASURE"

● **Command Format**

Destination node address	Service code	Class ID	Instance ID
10xx hex	0050 hex (fixed)	00A1 hex (fixed)	0000 hex (fixed)
2 bytes	2 bytes	2 bytes	2 bytes

● **Response Format**- **Normal Response**

Number of bytes received	Source node address	Service code
0004		00D0 hex (fixed)
2 bytes	2 bytes	2 bytes

- **Error Response**

Number of bytes received	Source node address	Service code	Error code
0006		0094 hex (fixed)	
2 bytes	2 bytes	2 bytes	2 bytes

### 3-6-6 GET MEASUREMENT VALUES

Reads the current measurement values.

Applicable Sensors	No-protocol command
ZS, ZG	"MEASURE"
ZFV-C	"DATAGET"

#### ● Command Format

Destination node address	Service code	Class ID	Instance ID	Data
10xx hex	0051 hex (fixed)	00A1 hex (fixed)	0000 hex (fixed)	Task number
2 bytes	2 bytes	2 bytes	2 bytes	1 byte

- Task number: Task number for which to read the measurement value (When the task number is set to 0, measurement values will be read for all tasks. This is applicable only for ZG-series Sensor Controllers.)

#### ● Response Format

The response format depends on the type of Sensor being used.

##### ■ ZS or ZFV-C

###### • Normal Response

Number of bytes received	Source node address	Service code	Data
000Chex		00D1 hex (fixed)	
2 bytes	2 bytes	2 bytes	8 bytes

Data		
C400 hex (fixed)	0400 hex (fixed)	Measurement value
2 bytes	2 bytes	4 bytes

###### • Error Response

Number of bytes received	Source node address	Service code	Error code
0006		0094 hex (fixed)	
2 bytes	2 bytes	2 bytes	2 bytes

■ ZG

- Normal Response for a Fixed Decimal Point

Task Number Not 0

Number of bytes received	Source node address	Service code	Data
000Chex		00D1 hex (fixed)	
2 bytes	2 bytes	2 bytes	8 bytes

Data			
C4 hex (fixed)	Number of integral digits	Data length	Measurement value
1 byte	1 byte	2 bytes	4 bytes

Task Number Is 0

Number of bytes received	Source node address	Service code	Data
0018 hex		00D1 hex (fixed)	
2 bytes	2 bytes	2 bytes	20 bytes

Data			
C4 hex (fixed)	Number of integral digits	Data length	Measurement value x 4
1 byte	1 byte	2 bytes	16 bytes

- Normal Response for a Floating Decimal Point

Task Number Not 0

Number of bytes received	Source node address	Service code	Data
000Chex		00D1 hex (fixed)	
2 bytes	2 bytes	2 bytes	8 bytes

Data		
CB00 hex (fixed)	Data length	Measurement value
2 bytes	2 bytes	4 bytes

Task Number Is 0

Number of bytes received	Source node address	Service code	Data
0018hex		00D1 hex (fixed)	
2 bytes	2 bytes	2 bytes	20 bytes

Data		
CB00 hex (fixed)	Data length	Measurement value x 4
2 bytes	2 bytes	16 bytes

**- Error Response**

Number of bytes received	Source node address	Service code	Error code
0006		0094 hex (fixed)	
2 bytes	2 bytes	2 bytes	2 bytes

Measurement values are read from the Sensor Controller as ASCII data. The Sensor Communications Unit converts the ASCII data to floating-point or fixed-decimal data.

Examples:

Fixed Decimal Point

Conditions

Number of integral digits: 3

Size: 16

If the value returned from the Sensor Controller is -999.999, the measurement value in the response will be 0xFFFF0BDC1 (-999999).

Floating Decimal Point

The floating decimal point will be converted according to the IEEE754 standard.

Condition

Size: 32

If the value returned from the Sensor Controller is -999.999, the measurement value in the response will be 0xc08F3FFDF3B645A2.

### 3-6-7 GET VERSION

Reads the Sensor Controller version.

Applicable Sensors	No-protocol command
ZS, ZG, ZFV-C	“VERGET”

● **Command Format**

Destination node address	Service code	Class ID	Instance ID
10xx hex	0052 hex (fixed)	00A1 hex (fixed)	0000 hex (fixed)
2 bytes	2 bytes	2 bytes	2 bytes

● **Response Format**

• **Normal Response**

Number of bytes received	Source node address	Service code	Data
Variable length		00D2 hex (fixed)	
2 bytes	2 bytes	2 bytes	Variable length

Data	
Size	Model + Version information
1 byte	Variable length

• **Error Response**

Number of bytes received	Source node address	Service code	Error code
0006		0094 hex (fixed)	
2 bytes	2 bytes	2 bytes	2 bytes

**3-6-8 INITIALIZE SETTINGS**

Returns all Sensor Controller data to the default settings.

Applicable Sensors	No-protocol command
ZG, ZFV-C	"DATAINIT"

- **Command Format**

Destination node address	Service code	Class ID	Instance ID
'10xx hex	0053 hex (fixed)	00A1 hex (fixed)	0000 hex (fixed)
2 bytes	2 bytes	2 bytes	2 bytes

- **Response Format**

- **Normal Response**

Number of bytes received	Source node address	Service code
0004		00D3 hex (fixed)
2 bytes	2 bytes	2 bytes

- **Error Response**

Number of bytes received	Source node address	Service code	Error code
0006		0094 hex (fixed)	
2 bytes	2 bytes	2 bytes	2 bytes

**Note:** When initializing the settings data with a ZS-series Sensor Controller, the communications settings for the Sensor Controller will return to CompoWay/F settings, and USB communications with the Sensor Communications Unit will result in an error. Reset the communications settings for the Sensor Controller to no-protocol communications

### 3-6-9 SAVE SETTINGS

Saves all bank data to flash memory in the Sensor Controller.

Applicable Sensors	No-protocol command
ZS, ZG, ZFV-C	"DATASAVE"

● **Command Format**

Destination node address	Service code	Class ID	Instance ID
10xx hex	0054 hex (fixed)	00A1 hex (fixed)	0000 hex (fixed)
2 bytes	2 bytes	2 bytes	2 bytes

● **Response Format**

· **Normal Response**

Number of bytes received	Source node address	Service code
0004		00D4 hex (fixed)
2 bytes	2 bytes	2 bytes

· **Error Response**

Number of bytes received	Source node address	Service code	Error code
0006		0094 hex (fixed)	
2 bytes	2 bytes	2 bytes	2 bytes



### 3-6-10 SWITCH BANK

Switches the current bank.

Applicable Sensors	No-protocol command
ZS, ZG, ZFV-C	"BANKSET"

#### ● Command Format

Destination node address	Service code	Class ID	Instance ID	Data
10xx hex	0055 hex (fixed)	00A1 hex (fixed)	0000 hex (fixed)	Bank number
2 bytes	2 bytes	2 bytes	2 bytes	1 byte

**Note:** When using a ZS-series Sensor Controller, set the bank number to the value obtained by subtracting 1 from the bank number.

#### ● Response Format

##### - Normal Response

Number of bytes received	Source node address	Service code
0004		00D5 hex (fixed)
2 bytes	2 bytes	2 bytes

##### - Error Response

Number of bytes received	Source node address	Service code	Error code
0006		0094 hex (fixed)	
2 bytes	2 bytes	2 bytes	2 bytes

### 3-6-11 GET BANK NUMBER

Reads the current bank number.

Applicable Sensors	No-protocol command
ZS, ZG, ZFV-C	"BANKGET"

● **Command Format**

Destination node address	Service code	Class ID	Instance ID
10xx hex	0056 hex (fixed)	00A1 hex (fixed)	0000 hex (fixed)
2 bytes	2 bytes	2 bytes	2 bytes

● **Response Format**

· **Normal Response**

Number of bytes received	Source node address	Service code	Data
0005		00D6 hex (fixed)	Bank number
2 bytes	2 bytes	2 bytes	1 byte

**Note:** When using a ZS-series Sensor Controller, the bank number that is read is one less than the actual bank number..

· **Error Response**

Number of bytes received	Source node address	Service code	Error code
0006		0094 hex (fixed)	
2 bytes	2 bytes	2 bytes	2 bytes

### 3-6-12 GET PROFILE

Reads the profile.

Applicable Sensors	No-protocol command
ZG	"PROFILE"

● **Command Format**

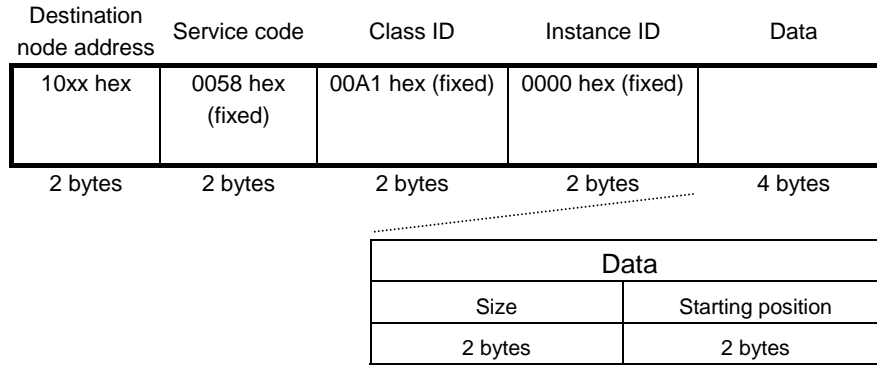

- Profile size: Size to be read (4 to 492; set in multiples of 4).
- Starting position: First address to be read (0 to 630).

**Note 1.** Each profile data item is 4 bytes (unit: nm). A total of 631 items can be read from the Sensor Controller (making a total of 2,524 bytes). Due to the size, a single explicit message cannot read all of this data. To read all of the data, the data must be split. Specify the starting position (data position) and size (in multiples of 4 bytes) for splitting the data, as shown in the following figure.

**Note 2.** The maximum profile data size that can be read using a single explicit message is 492 bytes.

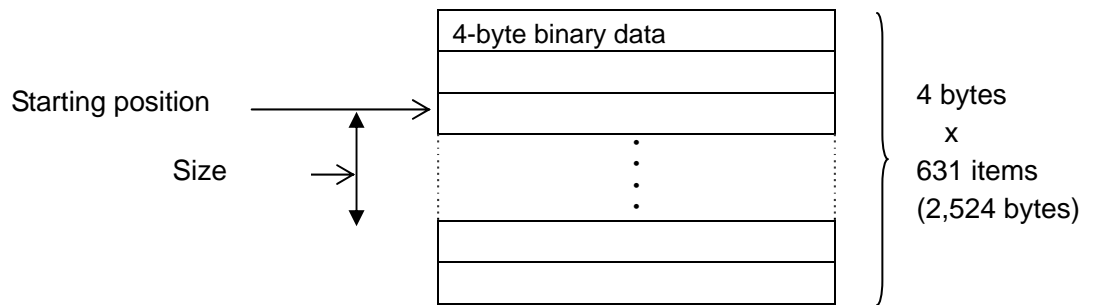

**Note 3.** The Sensor Communications Unit reads profile data from the Sensor Controller in the following instances:

1. When "0" is specified as the starting position.
2. When an explicit message is received immediately prior for the Sensor Controller relating to information other than the profile, profile data will be read from the Sensor Controller even though "0" is not specified as the starting position.

When reading profile data, obtain the profile that has a 0 starting position first, then change the starting position and continuously obtain profiles until they have all been read. If an explicit message is sent to the Sensor Controller before all of the profile data has been obtained, new profile data will be read from the Sensor Controller. To prevent this, do not send explicit messages to the Sensor Controller while profile data is being obtained.

● **Response Format**

- **Normal Response a Fixed Decimal Point**

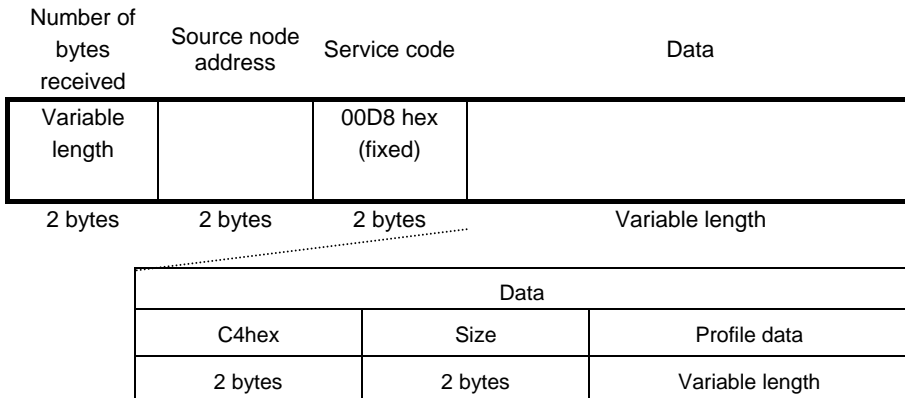

- **Normal Response a Floating Decimal Point**

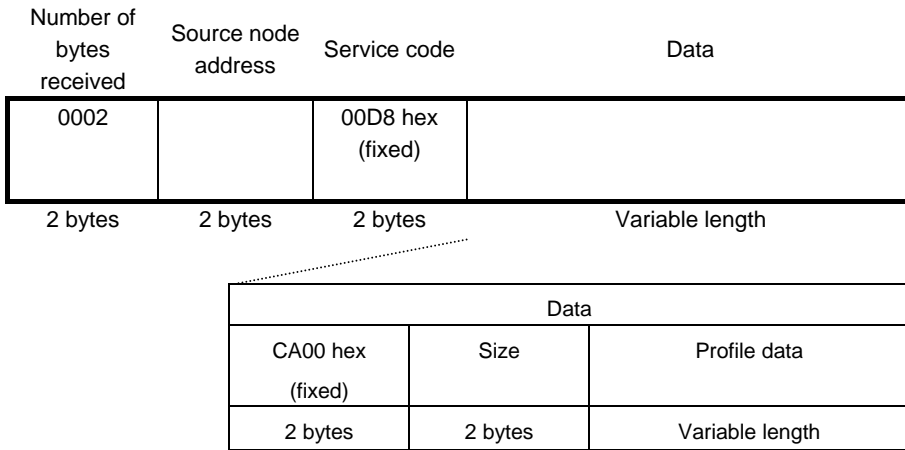

For information on the profile data, refer to the *ZG Series Smart Sensor 2D Profile Measuring Sensors User's Manual* (Cat. No. Z250).

- **Error Response**

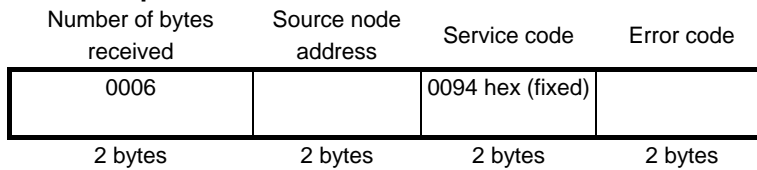

**3-6-13 GET FLOW DATA**

Reads the flow data.

Applicable Sensors	No-protocol command
ZS	"FLOWDATA"

- **Command Format**

Destina-  
tion node    Service code    Class ID    Instance ID  
address

10xx hex	0057 hex (fixed)	00A1 hex (fixed)	0000 hex (fixed)
2 bytes	2 bytes	2 bytes	2 bytes

- **Response Format**

- **Normal Response (Fixed Decimal Point)**

Number of    Source node    Service code    Data  
bytes received    address

0002		00D7 hex (fixed)	"
2 bytes	2 byte	2 bytes	Variable length

Data			
Size	Flow data	...	Flow data
2 bytes	8 bytes		8 bytes

For information on the flow data, refer to the ZS-series Sensor Controller User's Manual (Cat. No. Z250).

- **Error Response**

Number of bytes    Source node    Service code    Error code  
received    address

0006		0094 hex (fixed)	
2 bytes	2 bytes	2 bytes	2 bytes

To retrieve flow data, it is necessary to first set the logging conditions in the Sensor Communications Unit. The logging conditions are set by using the CompoNet Support Software.

■ Setting Logging Conditions

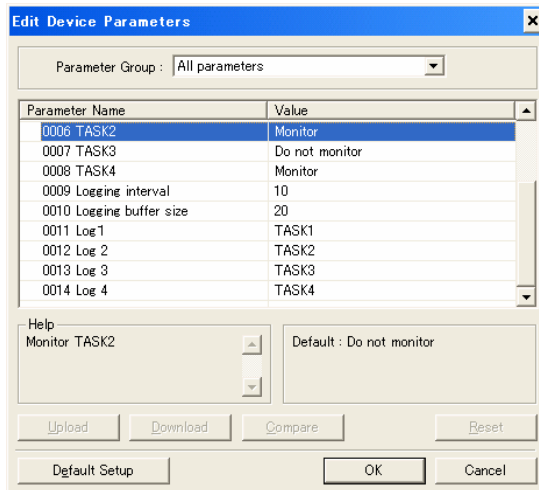

The logging conditions are set in the above dialog box. This is the same dialog box as the one used to select the data and tasks to be monitored.

Setting	Description
Monitor mode	<ul style="list-style-type: none"> <li>Constant monitoring (with I/O monitor) Select when not using data logging.</li> <li>Data logging (without I/O monitor) Select when using data logging.</li> </ul>
Logging interval	Set the logging interval. Set the logging interval to between 1 to 100. Logging is performed at the following interval: Measurement mode time set in the ZS-series Sensor Controller x Logging interval
Logging buffer size	Set the buffer size for storing temporary logging data.
Log 1 to Log 4	Register up to 4 tasks for logging. <ul style="list-style-type: none"> <li>Do not log. Select when not logging.</li> <li>Task 1 to Task 4 Select when logging the corresponding task.</li> </ul>

The relationship between the task to be logged and the Sensor Controller settings are shown in the following tables.

● ZS-LCD

A maximum of 3 items can be logged.

- Glass Thickness, Gap – Filmed, Other – Move

Contents	Task selected with CompoNet Support Software
Region 1 result	Task 1
Region 2 result	Task 2
Thickness/gap value	Task 3

- Glass Thickness/Gap Not Shown Above

Contents	Task selected with CompoNet Support Software
Thickness/gap value	Task 1

- All Other Cases

Contents	Task selected with CompoNet Support Software
Distance (measurement value)	Task 1

● **ZS-HLCD**

A maximum of 4 items can be logged.

· Multitask Mode Turned OFF

Measurements for Glass/Mode 2 or Glass Thickness/Mode 2

Contents	Task selected with CompoNet Support Software
Region 1 result	Task 1
Region 2 result	Task 2
Glass surface or thickness result	Task 3

· Measurements Other Than the Above

Contents	Task selected with CompoNet Support Software
Accumulation	Task 1

· Multitask Mode Turned ON

Contents	Task selected with CompoNet Support Software
Task 1 result	Task 1
Task 2 result	Task 2
Task 3 result	Task 3
Task 4 result	Task 4

● **ZS-MDC**

A maximum of 4 items can be logged.

Contents	Task selected with CompoNet Support Software
Accumulated data 1	Task 1
Accumulated data 2	Task 2
Accumulated data 3	Task 3
Accumulated data 4	Task 4

After setting the items to be monitored, download the parameters to the ZS-CRT.

■ **Remote I/O Communications Data during Data Logging**

The only data sent as remote I/O communications data during data logging is the status data.

Word m: Status

Bit	Description	Bit	Description
00	USB communications status	08	Reserved
01	USB communications error	09	Reserved
02	Reserved	10	Reserved
03	Reserved	11	Reserved
04	Reserved	12	Data logging running
05	Reserved	13	Overflow
06	Reserved	14	Reserved
07	Reserved	15	Reserved

● **Status**

- **USB Communications Status:**  
Turns ON when communications with the Sensor Controller has been established.
- **USB Communications Error:**  
Turns ON if a communications error occurs after communications with the Sensor Controller has been established.
- **Data Logging Running:**  
Turns ON when data is being logged.  
(ON: Data logging in progress, OFF: Data logging stopped)
- **Overflow:**  
Turns ON when an overflow occurs when collecting the flow data.  
If an overflow occurs, adjust send the GET FLOW DATA command more frequently from the PLC or increase the logging interval.

**3-6-14 List of Error Codes**

Response code	Error name	Cause
08FF	Service not supported	The service code is incorrect.
14FF	Invalid attribute value	The specified attribute value is not supported. The data written was outside valid range.
16FF	Object does not exist	The specified instance ID is not supported.
15FF	Too much data	The data is larger than the specified size.
13FF	Not enough data	The data is smaller than the specified size.
0CFF	Object state conflict	The specified command cannot be executed due to an internal error. Or an error response from the Sensor Controller or a timeout occurred.
20FF	Invalid parameter	The specified operation command data is not supported.



# Appendix

---

# Appendix 1 CompoNet Device Profile

## Appendix 1-1 Device Profile

Appendix

CompoNet Device Profile

Content	Setting	
Vendor ID	OMRON Corporation	47
Device type	Generic Device: 00H	
Product code	207	
Product name	ZS-CRT	
Revision	1.01	

## Appendix 1-2 Object Implementation

### Identity Object (0x01)

Object	Attribute	Not supported
Class	Service	Not supported

Object Instance 1	Attribute		GET SET	Value
	0x01	Vendor	Yes No	47
0x02	Device type	Yes No	Generic Device: 00H	
0x03	Product code	Yes No	207	
0x04	Revision	Yes No	1.01	
0x05	Status (bits supported)	Yes No	bit 0, bit 10	
0x06	Serial number	Yes No		
0x07	Product name	Yes No	ZS-CRT	
0x64	Protocol revision	Yes No	0101 (Ver. 1.1)	
Service			Parameter Option	
0x05	Reset	None		
0x0E	Get_Attribute_Single	None		

### Message Router Object (0x02)

Object	Attribute	Not supported
Class	Service	Not supported
Object Instance	Attribute	Not supported
	Service	Not supported
Addition of vendor specifics		None

Assembly Object (0x04)

Object	Attribute	Not supported
Class	Service	Not supported

Appendix

CompoNet Device Profile

Object Instance * *	Section	Data	Maximum number of instances		
	Type	Static I/O	1		
	Attribute		GET	SET	Value
	0x01	Number of Members in List	No	No	
	0x02	Member List	No	No	
	0x03	Data	Yes	Yes	
	Service		Parameter option		
	0x0E	Get_Attribute_Single	None		
	0x10	Set_Attribute_Single	None		

Input

Instance	Byte offset	Data							
		Bit 7							Bit 0
0x90 (144)	+0	IN data							
	:								
	+xx	IN data							
0x93 (147)	+0	Status							
	+1	Status							
	+2	IN data							
	:								
	+xx	IN data							

Output

Instance	Byte offset	Data							
		Bit 7							Bit 0
0xA0 (160)	+0	OUT data							
	:								
	+xx	OUT data							

Connection Object (0x05)

Object Class	Attribute		GET	SET	Value
	0x01	Revision	Yes	No	0x0001
Service			Parameter Option		
0x0E	Get_Attribute_Single	None			

Object Instance	Section	Data	Maximum number of instances		
	1	Instance type	POLL	1	
Production trigger		Cyclic			
Transport type		Server			
Transport class		2			
Attribute		GET	SET	Value	
0x01		State	Yes	No	
0x02		Instance type	Yes	No	00H
0x03		Transport class trigger	Yes	No	83H
0x04		Produced connection ID	Yes	No	
0x05		Consumed connection ID	Yes	No	
0x06		Initial comm. characteristics	Yes	No	21H
0x07		Produced connection size	Yes	No	64H
0x08		Consumed connection size	Yes	No	64H
0x09		Expected packed rate	Yes	Yes	
0x0C		Watchdog time-out action	Yes	Yes	One of 00,01
0x0D		Produced connection	Yes	No	00H
0x0E		Produced connection path	Yes	No	
0x0F	Consumed connection path length	Yes	No	00H	
0x10	Consumed connection path	Yes	No		
Service		Parameter Option			
0x05	Reset	None			
0x0E	Get_Attribute_Single	None			
0x10	Set_Attribute_Single	None			

CompoNet Link Object (0xF7)

Object Class	Attribute		GET	SET	Value
	0x01	Revision	Yes	No	0x0001
Service			Parameter Option		
0x0E	Get_Attribute_Single	None			

Object Instance	Attribute		GET	SET	Value	
	1	0x01	MAC ID	Yes	No	
0x02		Data rate	Yes	No		
0x05		Allocation choice	Yes	No		
0x0A		Explicit message timer	Yes	Yes		
Service			Parameter Option			
0x0E		Get_Attribute_Single	None			
0x10		Set_Attribute_Single	None			
0x4B	Allocate	Allocation choice, EPR, Explicit message timer				
0x4C	Release	Release choice				

**OMRON Corporation**  
**Industrial Automation Company**

**Sensing Devices Division H.Q.**  
**Application Sensors Division**  
Shiokoji Horikawa, Shimogyo-ku,  
Kyoto, 600-8530 Japan  
Tel: (81) 75-344-7068/Fax: (81) 75-344-7107

**Regional Headquarters**  
**OMRON EUROPE B.V.**  
Sensor Business Unit  
Carl-Benz-Str. 4, D-71154 Nufringen,  
Germany  
Tel: (49) 7032-811-0/Fax: (49) 7032-811-199

**OMRON ELECTRONICS LLC**  
One Commerce Drive Schaumburg,  
IL 60173-5302 U.S.A.  
Tel: (1) 847-843-7900/Fax: (1) 847-843-7787

**OMRON ASIA PACIFIC PTE. LTD.**  
No. 438A Alexandra Road # 05-05/08 (Lobby 2),  
Alexandra Technopark, Singapore 119967  
Tel: (65) 6835-3011/Fax: (65) 6835-2711

**OMRON (CHINA) CO., LTD.**  
Room 2211, Bank of China Tower,  
200 Yin Cheng Zhong Road,  
Pu Dong New Area, Shanghai, 200120, China  
Tel: (86) 21-5037-2222/Fax: (86) 21-5037-2200

**Authorized Distributor:**