

Machine Automation Controller
NX-series
Analog I/O Units

User's Manual
for High-speed Analog Input Units
NX-HAD□□□

Analog I/O Units





NOTE

All rights reserved. No part of this publication may be reproduced, stored in a retrieval system, or transmitted, in any form, or by any means, mechanical, electronic, photocopying, recording, or otherwise, without the prior written permission of OMRON.

No patent liability is assumed with respect to the use of the information contained herein. Moreover, because OMRON is constantly striving to improve its high-quality products, the information contained in this manual is subject to change without notice. Every precaution has been taken in the preparation of this manual. Nevertheless, OMRON assumes no responsibility for errors or omissions. Neither is any liability assumed for damages resulting from the use of the information contained in this publication.

Trademarks

- Sysmac and SYSMAC are trademarks or registered trademarks of OMRON Corporation in Japan and other countries for OMRON factory automation products.
- Microsoft, Windows, Excel, Visual Basic, and Microsoft Edge are either registered trademarks or trademarks of Microsoft Corporation in the United States and other countries.
- EtherCAT® is registered trademark and patented technology, licensed by Beckhoff Automation GmbH, Germany.
- Safety over EtherCAT® is registered trademark and patented technology, licensed by Beckhoff Automation GmbH, Germany.
- ODVA, CIP, CompoNet, DeviceNet, and EtherNet/IP are trademarks of ODVA.
- The SD and SDHC logos are trademarks of SD-3C, LLC.  

Other company names and product names in this document are the trademarks or registered trademarks of their respective companies.

Copyrights

Microsoft product screen shots used with permission from Microsoft.

Introduction

Thank you for purchasing an NX-series High-speed Analog Input Unit.

This manual contains information that is necessary to use the NX-series High-speed Analog Input Unit. Please read this manual and make sure you understand the functionality and performance of the High-speed Analog Input Unit before you attempt to use it in a control system.

Keep this manual in a safe place where it will be available for reference during operation.

Intended Audience

This manual is intended for the following personnel, who must also have knowledge of electrical systems (an electrical engineer or the equivalent).

- Personnel in charge of introducing FA systems.
- Personnel in charge of designing FA systems.
- Personnel in charge of installing and maintaining FA systems.
- Personnel in charge of managing FA systems and facilities.

For programming, this manual is intended for personnel who understand the programming language specifications in international standard IEC 61131-3 or Japanese standard JIS B 3503.

Applicable Products

This manual covers the following products.

- NX-series High-speed Analog Input Units
NX-HAD□□□

Relevant Manuals

To use the High-speed Analog Input Unit, you must refer to the manuals for all related products. Read all of the manuals that are relevant to your system configuration and application before you use the NX-series High-speed Analog Input Unit.

	(A) NX Units		System configuration				(D) Support Software		All Units		
	NX-series Analog I/O Units User's Manual for High-speed Analog Input Units	User's manuals for other NX Units	(B) CPU Units		(C) Slave Terminals		Sysmac Studio Version 1 Operation Manual	NX-IO Configurator Operation Manual	Sysmac Library User's Manual for High-speed Analog Inspection Library	NX-series System Units User's Manual	NX-series Data Reference Manual
NX-series NX102 CPU Unit Hardware User's Manual			NX-series NX1P2 CPU Unit Hardware User's Manual	NX-series CPU Unit Software User's Manual	NX-series EtherCAT Coupler Unit User's Manual	NX-series EtherNet/IP Coupler Unit User's Manual					
Learning about NX Units											
Specifications	<input type="radio"/>	<input type="radio"/>									
Functionality	<input type="radio"/>	<input type="radio"/>									
Application procedures	<input type="radio"/>	<input type="radio"/>									
Functions and function blocks for High-speed Analog Input Unit								<input type="radio"/>			
Wiring I/O power supply terminals and power supply terminals	<input type="radio"/>	<input type="radio"/>							<input type="radio"/>		
Learning about CPU Racks of NX-series CPU Units											
Specifications			<input type="radio"/>	<input type="radio"/>	<input type="radio"/>						
System configuration			<input type="radio"/>	<input type="radio"/>	<input type="radio"/>						
Power supply system			<input type="radio"/>	<input type="radio"/>					<input type="radio"/>		
Application procedures			<input type="radio"/>	<input type="radio"/>	<input type="radio"/>						
Installation procedures			<input type="radio"/>	<input type="radio"/>							
Support Software connection procedures					<input type="radio"/>						
Performance calculations					<input type="radio"/>						<input type="radio"/>
Learning about Slave Terminals											
Specifications						<input type="radio"/>	<input type="radio"/>				
System configuration						<input type="radio"/>	<input type="radio"/>				
Power supply system						<input type="radio"/>	<input type="radio"/>		<input type="radio"/>		
Application procedures						<input type="radio"/>	<input type="radio"/>				
Installation procedures						<input type="radio"/>	<input type="radio"/>				
Support Software connection procedures						<input type="radio"/>	<input type="radio"/>				
Performance calculations						<input type="radio"/>	<input type="radio"/>				<input type="radio"/>
Making settings								<input type="radio"/>	<input type="radio"/>		
Troubleshooting											
Troubleshooting CPU Racks or Slave Terminals			<input type="radio"/>	<input type="radio"/>	<input type="radio"/>	<input type="radio"/>	<input type="radio"/>	<input type="radio"/>	<input type="radio"/>		
Troubleshooting NX Units	<input type="radio"/>	<input type="radio"/>									

	(A) NX Units		System configuration				(D) Support Software		All Units				
			(B) CPU Units		(C) Slave Terminals								
	NX-series Analog I/O Units User's Manual for High-speed Analog Input Units	User's manuals for other NX Units	NX-series NX102 CPU Unit Hardware User's Manual	NX-series NX1P2 CPU Unit Hardware User's Manual	NX-series CPU Unit Software User's Manual	N/NX-series CPU Unit Software User's Manual	NX-series EtherCAT Coupler Unit User's Manual	NX-series EtherNet/IP Coupler Unit User's Manual	Sysmac Studio Version 1 Operation Manual	NX-IO Configurator Operation Manual	Sysmac Library User's Manual for High-speed Analog Inspection Library	NX-series System Units User's Manual	NX-series Data Reference Manual
Performing NX Unit maintenance	<input type="checkbox"/>	<input type="checkbox"/>											
Referencing data lists for NX Unit power consumptions, weights, etc.													<input type="checkbox"/>

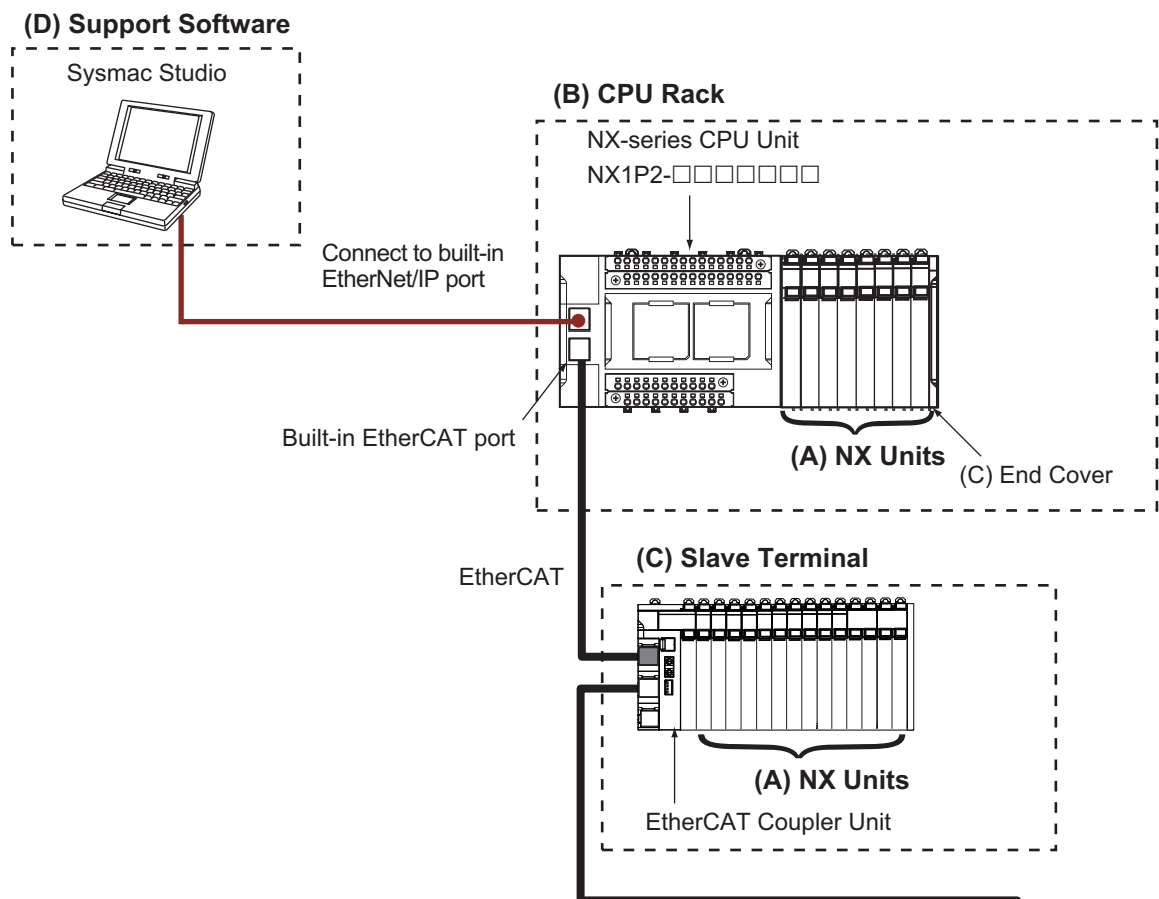

Manual Structure

Page Structure

The following page structure is used in this manual.

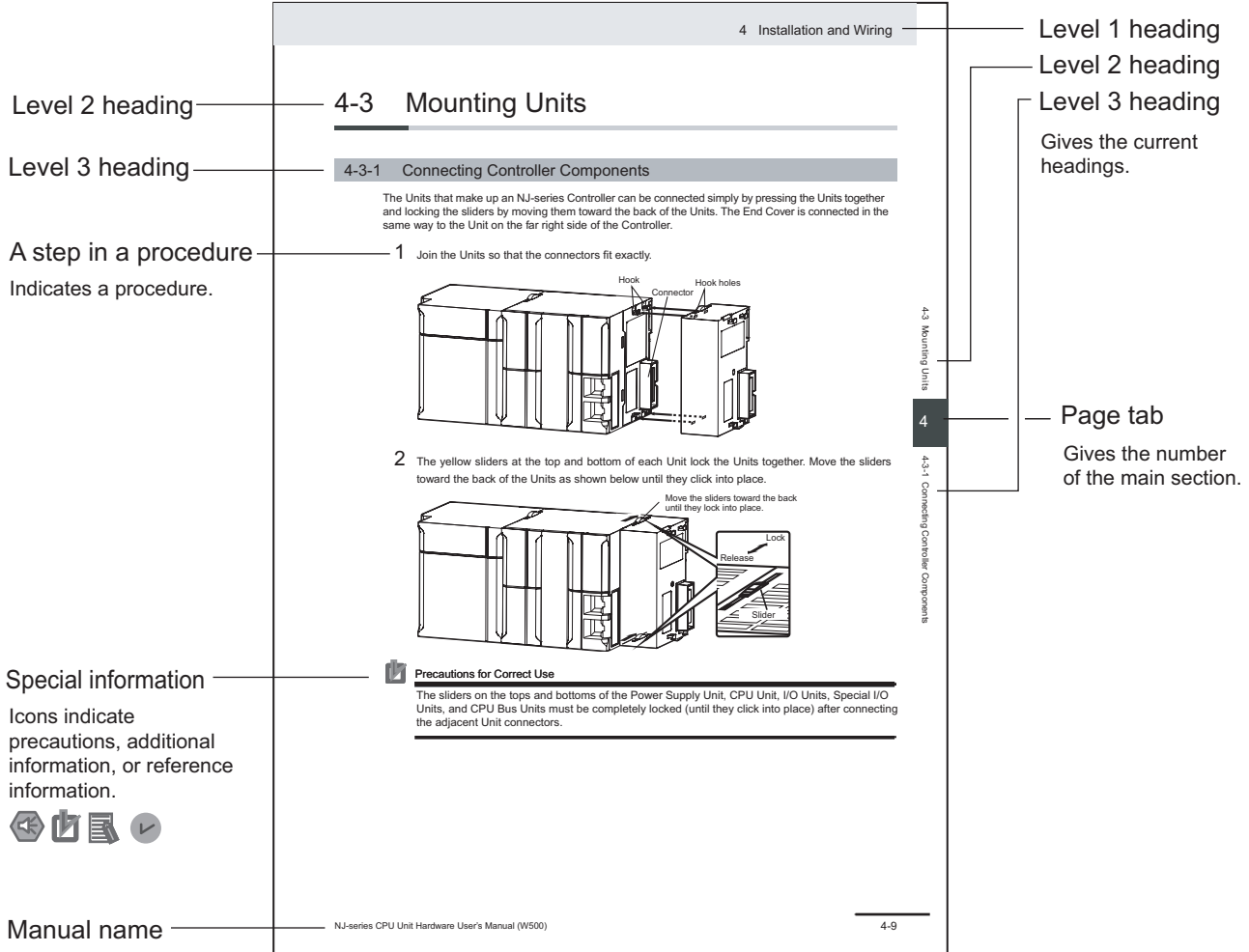

This illustration is provided only as a sample. It may not literally appear in this manual.

Special Information

Special information in this manual is classified as follows:



Precautions for Safe Use

Precautions on what to do and what not to do to ensure safe usage of the product.



Precautions for Correct Use

Precautions on what to do and what not to do to ensure proper operation and performance.



Additional Information

Additional information to read as required.

This information is provided to increase understanding or make operation easier.



Version Information

Information on differences in specifications and functionality for Controller with different unit versions and for different versions of the Sysmac Studio is given.

Precaution on Terminology

- In this manual, "download" refers to transferring data from the Support Software to a physical device and "upload" refers to transferring data from a physical device to the Support Software.
- In this manual, the directions in relation to the Units are given in the following figure, which shows upright installation.

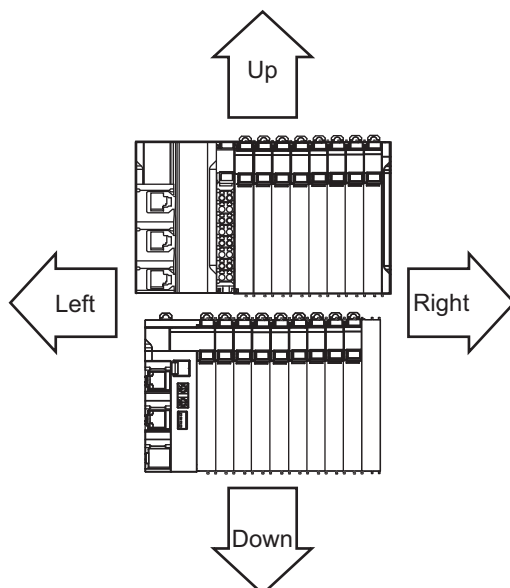

- This user's manual refers to "NY-series IPC Machine Controller Industrial Panel PCs and Industrial Box PCs" as simply "Industrial PCs" or as "NY-series Industrial PCs".

- This user's manual refers to the "built-in EtherCAT port on an NJ/NX-series Controller" or "built-in EtherCAT port on an NY-series Industrial PC" as simply a "built-in EtherCAT port".
- This user's manual may omit manual names and manual numbers in places that refer to the user's manuals for CPU Units and Industrial PCs. The following table gives some examples.

Examples:

Manual name	Omitted contents	Common text
NJ/NX-series CPU Unit Software User's Manual	Software user's manual for the connected CPU Unit or Industrial PC	Software User's Manual
NY-series IPC Machine Controller Industrial Panel PC / Industrial Box PC Software User's Manual		
NJ/NX-series CPU Unit Built-in EtherCAT® Port User's Manual	User's manual for the built-in EtherCAT port on the connected CPU Unit or Industrial PC	Built-in EtherCAT port
NY-series IPC Machine Controller Industrial Panel PC / Industrial Box PC Built-in EtherCAT® Port User's Manual		

- This user's manual may omit manual names and manual numbers in places that refer to the user's manuals for Communications Coupler Units.
- If the manual names and manual numbers for CPU Units are omitted, refer to *Related Manuals* on page 32 to determine the appropriate manual based on the common text for the omitted contents. If the manual names and manual numbers for Communications Coupler Units are omitted, refer to *Related Manuals* on page 32 to identify the manual for your Unit.

Sections in this Manual

1	Features and System Configuration	10	Inspection and Maintenance	1	10
2	Specifications and Operating Procedures	A	Appendices	2	A
3	Part Names and Functions	I	Index	3	I
4	Installation and Wiring			4	
5	I/O Refreshing			5	
6	Input Range and Converted Values			6	
7	I/O Data and List of Settings			7	
8	Functions			8	
9	Troubleshooting			9	

CONTENTS

Introduction	1
Intended Audience	1
Applicable Products	1
Relevant Manuals	2
Manual Structure	4
Page Structure	4
Special Information	5
Precaution on Terminology	5
Sections in this Manual	7
Terms and Conditions Agreement	13
Warranty, Limitations of Liability	13
Application Considerations	14
Disclaimers	14
Statement of security responsibilities for assumed use cases and against threats	15
Safety Precautions	16
Definition of Precautionary Information	16
Symbols	16
Warnings	17
Cautions	19
Precautions for Safe Use	20
Precautions for Correct Use	24
Regulations and Standards	26
Conformance to EU Directives	26
Conformance Requirement to EU Directives	27
Conformance to UL and CSA Standards	27
Conformance to Shipbuilding Standards	27
Conformance to KC Certification	27
Software Licenses and Copyrights	28
Unit Versions	29
Unit Versions	29
Unit Versions and Support Software Versions	31
Related Manuals	32
Terminology	36
Revision History	38

Section 1 Features and System Configuration

1-1 Features	1-2
1-2 System Configuration	1-5
1-2-1 System Configuration in the Case of a CPU Unit	1-5
1-2-2 System Configuration of Slave Terminals	1-6

1-2-3	Example of Application System Configuration	1-7
1-3	Model	1-9
1-3-1	Model Notation	1-9
1-3-2	Model List.....	1-9
1-4	List of Functions	1-11
1-5	Support Software	1-12

Section 2 Specifications and Operating Procedures

2-1	Specifications	2-2
2-1-1	General Specifications	2-2
2-1-2	Individual Specifications	2-2
2-2	Operating Procedures	2-3
2-2-1	Overall Procedure	2-3
2-2-2	Detailed Procedure for Configuring the Unit and Creating the User Program	2-4

Section 3 Part Names and Functions

3-1	Part Names	3-2
3-2	Indicators	3-3
3-2-1	TS Indicator	3-3
3-2-2	IN Indicator	3-4
3-2-3	Appearance Change of the Indicators.....	3-5
3-3	Terminal Blocks	3-6

Section 4 Installation and Wiring

4-1	Installing NX Units	4-2
4-1-1	Restriction on Installation Orientation	4-2
4-1-2	Restriction on Adjacent Units	4-3
4-2	Power Supply Types and Wiring	4-4
4-2-1	Power Supply Types	4-4
4-2-2	I/O Power Supply Applications and Methods	4-4
4-2-3	Calculating the Total Current Consumption from I/O Power Supply	4-5
4-3	Wiring the Terminals	4-7
4-3-1	Wiring to the Screwless Clamping Terminal Blocks	4-7
4-3-2	Preventing Incorrect Attachment of Terminal Blocks.....	4-17
4-3-3	Checking the Wiring	4-21
4-4	Wiring External Devices	4-22
4-4-1	Terminal Block Arrangement	4-22
4-4-2	Wiring Examples	4-22
4-4-3	Precautions for Wiring.....	4-25

Section 5 I/O Refreshing

5-1	I/O Refreshing	5-2
5-1-1	I/O Refreshing from CPU Units to NX Units	5-2
5-1-2	I/O Refreshing from CPU Units or Industrial PCs to Slave Terminal.....	5-3
5-1-3	Calculating the I/O Response Time of NX Units	5-4
5-2	I/O Refreshing Methods	5-6
5-2-1	Types of I/O Refreshing Methods.....	5-6
5-2-2	Setting the I/O Refreshing Methods	5-7

5-2-3	Restrictions in Refresh Cycles	5-8
5-2-4	I/O Refreshing Operation	5-9

Section 6 Input Range and Converted Values

6-1	Voltage Input Range and Converted Values	6-2
6-2	Current Input Range and Converted Values	6-5

Section 7 I/O Data and List of Settings

7-1	Specifications of I/O Data	7-2
7-1-1	Allocatable I/O Data	7-2
7-1-2	Data Details	7-6
7-1-3	Precautions for the I/O Data Size	7-12
7-2	Setting I/O Allocations with the Sysmac Studio	7-14
7-2-1	Displaying the Edit I/O Allocation Settings Window	7-14
7-2-2	Displayed I/O Allocation Settings	7-16
7-2-3	Configuring the I/O Allocation Settings	7-18
7-3	List of Settings	7-20

Section 8 Functions

8-1	Function Block Diagram	8-3
8-2	Selecting Channel To Use	8-4
8-2-1	Function Applications and Overview	8-4
8-2-2	Details on the Function	8-4
8-2-3	Setting Method	8-5
8-3	Input Range Selection	8-6
8-3-1	Function Applications and Overview	8-6
8-3-2	Details on the Function	8-6
8-3-3	Setting Method	8-6
8-4	Number of Samplings Setting	8-8
8-4-1	Function Applications and Overview	8-8
8-4-2	Details on the Function	8-8
8-4-3	Setting Method	8-11
8-4-4	Checking the Sampling Settings	8-11
8-5	Digital Filtering	8-18
8-5-1	Function Applications and Overview	8-18
8-5-2	Details on the Function	8-18
8-5-3	Setting Method	8-27
8-5-4	Checking the Digital Filter Settings	8-28
8-6	Input Disconnection Detection	8-29
8-6-1	Function Applications and Overview	8-29
8-6-2	Details on the Function	8-29
8-6-3	Setting Method	8-30
8-7	Over Range/Under Range Detection	8-31
8-7-1	Function Applications and Overview	8-31
8-7-2	Details on the Function	8-31
8-7-3	Setting Method	8-32
8-8	User Calibration	8-33
8-8-1	Function Applications and Overview	8-33
8-8-2	Details on the Function	8-33
8-8-3	Setting Method	8-34

8-9	Zero Set/Reset	8-38
8-9-1	Function Applications and Overview	8-38
8-9-2	Details on the Function	8-38
8-9-3	Setting Method	8-39
8-10	Trigger Input	8-40
8-10-1	Function Applications and Overview	8-40
8-10-2	Details on the Function	8-40
8-10-3	Identifying the Analog Input Value When Trigger Input Was Turned ON	8-45
8-10-4	Setting Method	8-47
8-11	Input Filter	8-48
8-11-1	Function Applications and Overview	8-48
8-11-2	Details on the Function	8-48
8-11-3	Setting Method	8-49

Section 9 Troubleshooting

9-1	How to Check for Errors	9-2
9-2	Checking for Errors with the Indicators	9-3
9-3	Checking for Errors and Troubleshooting on the Support Software	9-5
9-3-1	Checking for Errors from the Sysmac Studio	9-5
9-3-2	Checking for Errors from Support Software Other Than the Sysmac Studio	9-6
9-3-3	Event Codes and Corrections for Errors	9-6
9-3-4	Meaning of Error	9-12
9-4	Resetting Errors	9-35
9-5	Unit-specific Troubleshooting	9-36
9-6	Analog Input Value When an Error Occurs	9-39
9-7	Troubleshooting Flowchart	9-40

Section 10 Inspection and Maintenance

10-1	Cleaning and Inspection	10-2
10-1-1	Cleaning	10-2
10-1-2	Periodic Inspections	10-2
10-2	Maintenance Procedures	10-5

Appendices

A-1	Data Sheet	A-2
A-1-1	Model List.....	A-2
A-1-2	High-speed Analog Input Units	A-3
A-2	Dimensions	A-11
A-3	Programming Examples for Analog Input Data Collection with the Library	A-13
A-3-1	System Configuration	A-13
A-3-2	Programming Example.....	A-13
A-3-3	Connection to the Communications Coupler Unit	A-17
A-4	Digital Filter Design with the Library	A-21
A-4-1	System Configuration.....	A-21
A-4-2	Digital Filter Design Examples	A-21
A-4-3	Programming Example.....	A-25
A-4-4	Connection to the Communications Coupler Unit	A-34
A-5	List of NX Objects	A-38
A-5-1	Format of NX Object Descriptions.....	A-38

A-5-2	Unit Information Objects.....	A-38
A-5-3	Objects That Accept I/O Allocations.....	A-40
A-5-4	Other Objects.....	A-45
A-6	Version Information with CPU Units	A-51
A-6-1	Relationship between Unit Versions of Units	A-51
A-7	Version Information with Communications Coupler Units	A-52
A-7-1	Connection to an EtherCAT Coupler Unit.....	A-52
A-8	Displaying the Edit Unit Operation Settings Tab Page.....	A-54
A-8-1	Connection to the CPU Unit.....	A-54
A-8-2	Slave Terminal.....	A-55
A-9	Edit Unit Operation Settings Tab Page	A-57
A-10	Displaying the User Calibration Window.....	A-59
A-10-1	Connection to the CPU Unit.....	A-59
A-10-2	Slave Terminal.....	A-60

Index

Terms and Conditions Agreement

Warranty, Limitations of Liability

Warranties

- **Exclusive Warranty**

Omron's exclusive warranty is that the Products will be free from defects in materials and workmanship for a period of twelve months from the date of sale by Omron (or such other period expressed in writing by Omron). Omron disclaims all other warranties, express or implied.

- **Limitations**

OMRON MAKES NO WARRANTY OR REPRESENTATION, EXPRESS OR IMPLIED, ABOUT NON-INFRINGEMENT, MERCHANTABILITY OR FITNESS FOR A PARTICULAR PURPOSE OF THE PRODUCTS. BUYER ACKNOWLEDGES THAT IT ALONE HAS DETERMINED THAT THE PRODUCTS WILL SUITABLY MEET THE REQUIREMENTS OF THEIR INTENDED USE.

Omron further disclaims all warranties and responsibility of any type for claims or expenses based on infringement by the Products or otherwise of any intellectual property right.

- **Buyer Remedy**

Omron's sole obligation hereunder shall be, at Omron's election, to (i) replace (in the form originally shipped with Buyer responsible for labor charges for removal or replacement thereof) the non-complying Product, (ii) repair the non-complying Product, or (iii) repay or credit Buyer an amount equal to the purchase price of the non-complying Product; provided that in no event shall Omron be responsible for warranty, repair, indemnity or any other claims or expenses regarding the Products unless Omron's analysis confirms that the Products were properly handled, stored, installed and maintained and not subject to contamination, abuse, misuse or inappropriate modification. Return of any Products by Buyer must be approved in writing by Omron before shipment. Omron Companies shall not be liable for the suitability or unsuitability or the results from the use of Products in combination with any electrical or electronic components, circuits, system assemblies or any other materials or substances or environments. Any advice, recommendations or information given orally or in writing, are not to be construed as an amendment or addition to the above warranty.

See <https://www.omron.com/global/> or contact your Omron representative for published information.

Limitation on Liability; Etc

OMRON COMPANIES SHALL NOT BE LIABLE FOR SPECIAL, INDIRECT, INCIDENTAL, OR CONSEQUENTIAL DAMAGES, LOSS OF PROFITS OR PRODUCTION OR COMMERCIAL LOSS IN ANY

WAY CONNECTED WITH THE PRODUCTS, WHETHER SUCH CLAIM IS BASED IN CONTRACT, WARRANTY, NEGLIGENCE OR STRICT LIABILITY.

Further, in no event shall liability of Omron Companies exceed the individual price of the Product on which liability is asserted.

Application Considerations

Suitability of Use

Omron Companies shall not be responsible for conformity with any standards, codes or regulations which apply to the combination of the Product in the Buyer's application or use of the Product. At Buyer's request, Omron will provide applicable third party certification documents identifying ratings and limitations of use which apply to the Product. This information by itself is not sufficient for a complete determination of the suitability of the Product in combination with the end product, machine, system, or other application or use. Buyer shall be solely responsible for determining appropriateness of the particular Product with respect to Buyer's application, product or system. Buyer shall take application responsibility in all cases.

NEVER USE THE PRODUCT FOR AN APPLICATION INVOLVING SERIOUS RISK TO LIFE OR PROPERTY OR IN LARGE QUANTITIES WITHOUT ENSURING THAT THE SYSTEM AS A WHOLE HAS BEEN DESIGNED TO ADDRESS THE RISKS, AND THAT THE OMRON PRODUCT(S) IS PROPERLY RATED AND INSTALLED FOR THE INTENDED USE WITHIN THE OVERALL EQUIPMENT OR SYSTEM.

Programmable Products

Omron Companies shall not be responsible for the user's programming of a programmable Product, or any consequence thereof.

Disclaimers

Performance Data

Data presented in Omron Company websites, catalogs and other materials is provided as a guide for the user in determining suitability and does not constitute a warranty. It may represent the result of Omron's test conditions, and the user must correlate it to actual application requirements. Actual performance is subject to the Omron's Warranty and Limitations of Liability.

Change in Specifications

Product specifications and accessories may be changed at any time based on improvements and other reasons. It is our practice to change part numbers when published ratings or features are changed, or when significant construction changes are made. However, some specifications of the Product may

be changed without any notice. When in doubt, special part numbers may be assigned to fix or establish key specifications for your application. Please consult with your Omron's representative at any time to confirm actual specifications of purchased Product.

Errors and Omissions

Information presented by Omron Companies has been checked and is believed to be accurate; however, no responsibility is assumed for clerical, typographical or proofreading errors or omissions.

Statement of security responsibilities for assumed use cases and against threats

OMRON SHALL NOT BE RESPONSIBLE AND/OR LIABLE FOR ANY LOSS, DAMAGE, OR EXPENSES DIRECTLY OR INDIRECTLY RESULTING FROM THE INFECTION OF OMRON PRODUCTS, ANY SOFTWARE INSTALLED THEREON OR ANY COMPUTER EQUIPMENT, COMPUTER PROGRAMS, NETWORKS, DATABASES OR OTHER PROPRIETARY MATERIAL CONNECTED THERETO BY DISTRIBUTED DENIAL OF SERVICE ATTACK, COMPUTER VIRUSES, OTHER TECHNOLOGICALLY HARMFUL MATERIAL AND/OR UNAUTHORIZED ACCESS.

It shall be the users sole responsibility to determine and use adequate measures and checkpoints to satisfy the users particular requirements for (i) antivirus protection, (ii) data input and output, (iii) maintaining a means for reconstruction of lost data, (iv) preventing Omron Products and/or software installed thereon from being infected with computer viruses and (v) protecting Omron Products from unauthorized access.



Safety Precautions

Definition of Precautionary Information





The following notation is used in this manual to provide precautions required to ensure safe usage of the NX-series High-speed Analog Input Units.

The safety precautions that are provided are extremely important to safety. Always read and heed the information provided in all safety precautions.

The following notation is used.

 WARNING	<p>Indicates a potentially hazardous situation which, if not avoided, could result in death or serious injury. Additionally, there may be severe property damage.</p>
 Caution	<p>Indicates a potentially hazardous situation which, if not avoided, may result in minor or moderate injury, or property damage.</p>

Symbols

	<p>The circle and slash symbol indicates operations that you must not do. The specific operation is shown in the circle and explained in text. This example indicates prohibiting disassembly.</p>
	<p>The triangle symbol indicates precautions (including warnings). The specific operation is shown in the triangle and explained in text. This example indicates a precaution for electric shock.</p>
	<p>The triangle symbol indicates precautions (including warnings). The specific operation is shown in the triangle and explained in text. This example indicates a general precaution.</p>
	<p>The filled circle symbol indicates operations that you must do. The specific operation is shown in the circle and explained in text. This example shows a general precaution for something that you must do.</p>

Warnings

WARNING

During Power Supply

Do not touch the terminal section while power is ON.
Electric shock may occur.



Do not attempt to take any Unit apart.
In particular, high-voltage parts are present in Units that supply power while power is supplied or immediately after power is turned OFF. Touching any of these parts may result in electric shock. There are sharp parts inside the Unit that may cause injury.



Fail-safe Measures

Provide safety measures in external circuits to ensure safety in the system if an abnormality occurs due to malfunction of the CPU Unit, Industrial PC, other Units, or slaves or due to other external factors affecting operation.
Not doing so may result in serious accidents due to incorrect operation.



Emergency stop circuits, interlock circuits, limit circuits, and similar safety measures must be provided in external control circuits.



The CPU Unit or Industrial PC will turn OFF all outputs from Output Units in the following cases. The remote I/O slaves will operate according to the settings in the slaves.

- If a power supply error occurs.
- If the power supply connection becomes faulty.
- If a CPU watchdog timer error or CPU reset occurs.
- If a Controller error in the major fault level occurs.
- While the CPU Unit is on standby until RUN mode is entered after the power is turned ON



External safety measures must be provided to ensure safe operation of the system in such cases.

The outputs may remain ON or OFF due to deposition or burning of the output relays or destruction of the output transistors. As a countermeasure for such problems, external safety measures must be provided to ensure safe operation of the system.



If external power supplies for slaves or other devices are overloaded or short-circuited, the voltage will drop, outputs will turn OFF, and the system may be unable to read inputs. Provide external safety measures in control with monitoring of external power supply voltage as required so that the system operates safely in such a case.



You must take fail-safe measures to ensure safety in the event of incorrect, missing, or abnormal signals caused by broken signal lines, momentary power interruptions, or other causes.



Not doing so may result in serious accidents due to incorrect operation.

Voltage and Current Inputs

Make sure that the voltages and currents that are input to the Units and slaves are within the specified ranges.

Inputting voltages or currents that are outside of the specified ranges may cause accidents or fire.



Transferring

Always confirm safety at the destination node before you transfer Unit configuration information, parameters, settings, or other data from tools such as the Sysmac Studio.

The devices or machines may operate unexpectedly, regardless of the operating mode of the Controller.



Cautions

⚠ Caution

Wiring

When you connect a computer or other peripheral device to a Communications Coupler Unit that has a non-isolated DC power supply, either ground the 0-V side of the external power supply (i.e. Unit power supply) or do not ground it at all.

If the peripheral devices are grounded incorrectly, the external power supply (i.e. Unit power supply) may be short-circuited.

Never ground the 24-V side of the power supply, as shown in the following figure.

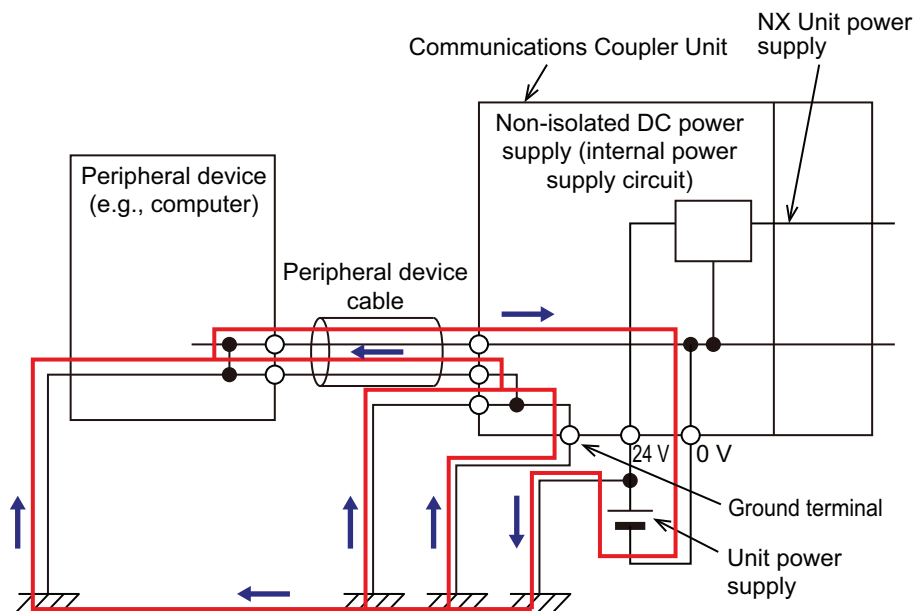

Be sure that all terminal screws and cable connector screws are tightened to the torque specified in the relevant manuals. The loose screws may result in fire or malfunction.



Online Editing

Execute online editing only after confirming that no adverse effects will be caused by deviations in the timing of I/O. If you perform online editing, the task execution time may exceed the task period, I/O may not be refreshed with external devices, input signals may not be read, and output timing may change.



Precautions for Safe Use

Transporting

- When transporting any Unit, use the special packing box for it.
Also, do not subject the Unit to excessive vibration or shock during transportation.
- Do not drop any Unit or subject it to abnormal vibration or shock.
Doing so may result in Unit malfunction or burning.

Mounting

- Mount terminal blocks and connectors only after checking the mounting location carefully.
- Be sure that the terminal blocks, expansion cables, and other items with locking devices are properly locked into place.

Installation

- Always turn OFF the power supply before installing the Unit. If the power supply is not OFF, the Unit may malfunction or may be damaged.
- Always turn OFF the Unit power supply and I/O power supply before you remove the NX Unit.
- Do not apply labels or tape to the Unit. When the Unit is installed or removed, adhesive or scraps may adhere to the pins in the NX bus connector, which may result in malfunctions.
- Do not touch the pins in the NX bus connector on the Unit. Dirt may adhere to the pins in the NX bus connector, which may result in malfunctions.

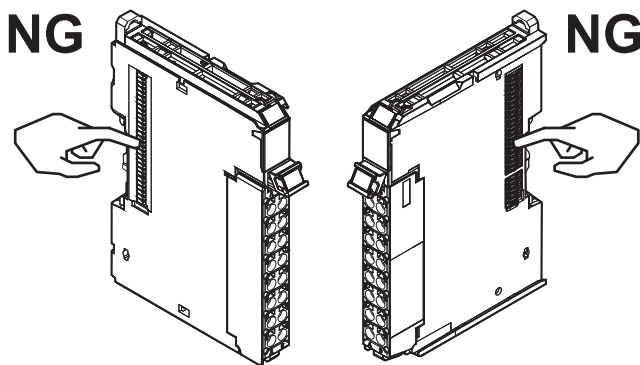

Example: NX Unit (12 mm width)

- Do not write on an NX Unit with ink within the restricted region that is shown in the following figure. Also do not get this area dirty. When the Unit is installed or removed, ink or dirt may adhere to the pins in the NX bus connector, which may result in malfunctions in the CPU Rack or the Slave Terminal.
Refer to the user's manual for the connected CPU Unit, Communications Coupler Unit, or Communication Control Unit for details on the restricted region on the CPU Unit, Communications Coupler Unit, or Communication Control Unit.

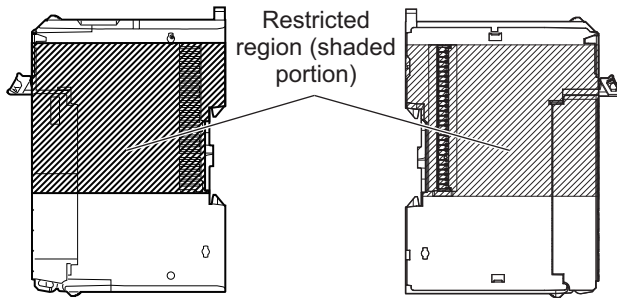

Wiring

- Double-check all switches and other settings and double-check all wiring to make sure that they are correct before turning ON the power supply.
- Use the correct wiring parts and tools when you wire the system.
- Do not pull on the cables or bend the cables beyond their natural limit. Also, do not place heavy objects on top of the cables or other wiring lines. Doing so may break the cable.
- When wiring or installing the Units, do not allow metal fragments to enter the Units.
- Do not press the flat-blade screwdriver straight into the release holes on a screwless clamping terminal block. Doing so may damage the terminal block.

NG

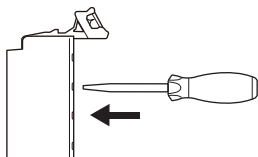

OK

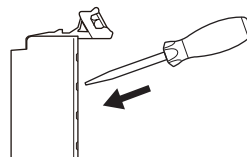

- When you insert a flat-blade screwdriver into a release hole on a screwless clamping terminal block, press it down with a force of 30N or less. Applying excessive force may damage the terminal block.
- Do not incline or twist the flat-blade screwdriver while it is in a release hole on a screwless clamping terminal block. Doing so may damage the terminal block.

NG

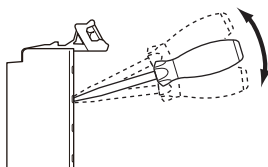

NG

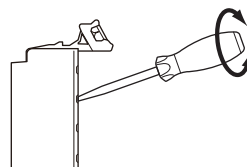

- If you use reed switches for the input contacts for AC Input Units, use switches with an allowable current of 1 A or greater. If the capacity of the reed switches is too low, inrush current may fuse the contacts.
- Use crimp terminals for wiring the M3 screw terminal blocks. Do not connect bare stranded wires directly to the M3 screw terminal blocks.

Power Supply Design

- Use all Units within the I/O power supply ranges that are given in the specifications.
- The I/O power supply current for the CPU Rack with an NX-series CPU Unit should be within the range specified for the CPU Unit model. For example, use the NX1P2 CPU Unit with a current of 4 A or less. Using the currents that are outside of the specifications may cause failure or corruption. Refer to the user's manual for the connected CPU Unit for the I/O power supply current for the CPU Unit model.
- Supply sufficient power according to the contents of this manual.
- Use the power supply voltage that is specified in this manual.
- Do not apply voltages that exceed the rated value to any Input Unit.
- Do not apply voltages or connect loads to the Output Units or slaves in excess of the maximum ratings.
- Inrush current occurs when the power supply is turned ON. When selecting fuses or breakers for external circuits, consider their fusing and detection characteristics as well as the above precautions and allow sufficient margin in shut-off performance.
- Install external breakers and take other safety measures against short-circuiting and overcurrents in external wiring.

Turning ON the Power Supply

- When you set the Operating Mode at Startup, confirm that no adverse effect will occur in the system.

Actual Operation

- Before you start operation, always register the NX Units that are connected to the Communications Coupler Unit in the host communications master as the Unit Configuration Information.
- Check the user program, data, and parameter settings for proper execution before you use them for actual operation.
- If you change the fail-soft operation setting, the output status when the error occurs may also change. Confirm safety before you change the fail-soft operation setting.
- If you use fail-soft operation, write programming to determine whether Unit I/O data is valid. Without such programming, the user program cannot distinguish between Units for which I/O refreshing is continued and Units for which I/O refreshing is stopped.

Turning OFF the Power Supply

- Do not disconnect the cable or turn OFF the power supply to the Controller or a Slave Terminal when downloading data or the user program from the Support Software.
- Always turn OFF the external power supply to the Units before attempting any of the following.
 - a) Mounting or removing an NX Unit, Communications Coupler Unit, CPU Unit, Industrial PC, or Communication Control Unit
 - b) Assembling Units
 - c) Setting DIP switches or rotary switches
 - d) Connecting or wiring cables

- e) Attaching or removing terminal blocks or connectors

Units that supply power continue to supply power to the Units for up to several seconds after the power supply is turned OFF. The PWR indicator remains lit as long as power is supplied. Confirm that the PWR indicator is not lit before you perform any of the above.

Operation

- Confirm that the controlled system will not be adversely affected before you perform any of the following operations.
 - a) Changing the operating mode of the CPU Unit or Industrial PC (including changing the setting of the Operating Mode at Startup)
 - b) Changing the user program or settings
 - c) Changing set values or present values
 - d) Forced refreshing
- Always sufficiently check the safety at the connected devices before you change the settings of a slave or Unit.

General Communications

- Do not exceed the ranges that are given in the specifications for the communications distance and number of connected Units.
- Refer to the user's manual for the Communications Coupler Unit for precautions for the safe use of communications with the connected Communications Coupler Unit.

Unit Replacement

- When you replace a Unit, start operation only after you transfer the settings and variables that are required for operation to the new Unit.

Disposal

- Dispose of the product according to local ordinances as they apply.

Using the High-speed Analog Input Unit

- The High-speed Analog Input Units can be used only in the upright orientation. Otherwise, Unit failure or malfunction may occur.
- Do not connect the High-speed Analog Input Units next to a Relay Output Unit. Otherwise, Unit malfunction may occur.

Precautions for Correct Use

Storage, Mounting, and Wiring

- Follow the instructions in this manual to correctly perform installation and wiring.
- Do not operate or store the Units in the following locations. Doing so may result in malfunction, in operation stopping, or in burning.
 - Locations subject to direct sunlight
 - Locations subject to temperatures or humidity outside the range specified in the specifications
 - Locations subject to condensation as the result of severe changes in temperature
 - Locations subject to corrosive or flammable gases
 - Locations subject to dust (especially iron dust) or salts
 - Locations subject to exposure to water, oil, or chemicals
 - Locations subject to shock or vibration
- Take appropriate and sufficient countermeasures during installation in the following locations.
 - Locations subject to strong, high-frequency noise
 - Locations subject to static electricity or other forms of noise
 - Locations subject to strong electromagnetic fields
 - Locations subject to possible exposure to radioactivity
 - Locations close to power lines
- Before touching a Unit, be sure to first touch a grounded metallic object in order to discharge any static build-up.
- Use the rated power supply voltage for the Units that supply power. Take appropriate measures to ensure that the specified power with the rated voltage and frequency is supplied in places where the power supply is unstable.
- Install the Units away from sources of heat and ensure proper ventilation. Not doing so may result in malfunction, in operation stopping, or in burning.
- Do not allow foreign matter to enter the openings in the Unit. Doing so may result in Unit burning, electric shock, or failure.

Actual Operation

- If you change the event level of an error, the output status when the error occurs may also change. Confirm safety before you change an event level.

Turning OFF the Power Supply

- Do not turn OFF the power supply while data is being transferred.
- Do not turn OFF the power supply while parameters are being written to the CPU Unit, Communications Coupler Unit, Communication Control Unit, or NX Units.

General Communications

- Refer to the user's manual for the Communications Coupler Unit for precautions for the correct use of communications with the connected Communications Coupler Unit.
- Refer to the user's manual for the Communication Control Unit for precautions for the correct use of communications with the connected Communication Control Unit.

Regulations and Standards

Conformance to EU Directives

Applicable Directives

- EMC Directives
- Low Voltage Directive

Concepts

● EMC Directives

OMRON devices that comply with EU Directives also conform to the related EMC standards so that they can be more easily built into other devices or the overall machine. The actual products have been checked for conformity to EMC standards.*1

Whether the products conform to the standards in the system used by the customer, however, must be checked by the customer. EMC-related performance of the OMRON devices that comply with EU Directives will vary depending on the configuration, wiring, and other conditions of the equipment or control panel on which the OMRON devices are installed. The customer must, therefore, perform the final check to confirm that devices and the overall machine conform to EMC standards.

*1. Applicable EMC (Electromagnetic Compatibility) standards are as follows: EMS (Electromagnetic Susceptibility): EN 61131-2, EMI (Electromagnetic Interference): EN 61131-2 (Radiated emission: 10-m regulations).

● Low Voltage Directive

Always ensure that devices operating at voltages of 50 to 1,000 VAC and 75 to 1,500 VDC meet the required safety standards. The applicable directive is EN 61010-2-201.

● Conformance to EU Directives

The NX-series Units comply with EU Directives. To ensure that the machine or device in which the NX-series Units are used complies with EU Directives, the following precautions must be observed.

- The NX-series Units must be installed within a control panel.
- You must use SELV power supply for the DC power supplies that are connected as the Unit power supplies and I/O power supplies for the NX-series Units.

EMC standard compliance was confirmed for the recommended Power Supplies. Refer to the user's manual for the connected CPU Unit for information on the recommended Power Supplies for the CPU Rack of the NX-series CPU Unit. If your High-speed Analog Input Unit is connected to a Slave Terminal, we recommend that you use the OMRON S8VK-S-series Power Supplies.

- NX-series Units that comply with EU Directives also conform to the Common Emission Standard (EN 61131-2). Radiated emission characteristics (10-m regulations) may vary depending on the configuration of the control panel used, other devices connected to the control panel, wiring, and other conditions.

You must therefore confirm that the overall machine or equipment in which the NX-series Units are used complies with EU Directives.

- You must use power supplies with an output hold time of 10 ms or longer for the DC power supplies that are connected as the Unit power supplies and I/O power supplies for the NX-series Units.
- This is a Class A product (for industrial environments). In a residential environment, it may cause radio interference. If radio interference occurs, the user may be required to take appropriate measures.

Conformance Requirement to EU Directives

The immunity test conditions for the NX-series High-speed Analog Input Units are as follows:

Model	Overall accuracy of analog input section	Digital filtering	Input filter for trigger input
<ul style="list-style-type: none"> • NX-HAD401 • NX-HAD402 	6%/-6%	<ul style="list-style-type: none"> • Digital low-pass filter: Disabled • Moving average filter 1: Disabled • Moving average filter 2: Disabled 	4 μ s

Use a shield wire (2 conductors, twisted wire) to connect the High-speed Analog Input Units. The compatibility was confirmed in a condition that the shield wire was not connected. The compatibility was also confirmed in a configuration where the I/O wiring was less than 30 m.

Conformance to UL and CSA Standards

Some NX-series products comply with UL and CSA standards.

If you use an NX-series product that complies with UL or CSA standards and the machinery or system in which you use the NX-series product must also comply with the standards, refer to the *Instruction Sheet* that is provided with the product. The *Instruction Sheet* provides the application conditions for complying with the standards.

Conformance to Shipbuilding Standards

Some NX-series products comply with shipbuilding standards.

If you use an NX-series product that complies with shipbuilding standards and the machinery or system in which you use the NX-series product must also comply with the standards, consult with your OMRON representative. Application conditions are defined according to the installation location. Application may not be possible for some installation locations.

For usage conditions for shipbuilding standards, refer to *Conformance to Shipping Standards* in the user's manual for the CPU Unit or Communications Coupler Unit that the NX Units are connected to. Note that the usage conditions are provided in the relevant user's manuals for Units whose conformance to shipbuilding standards is confirmed.

Conformance to KC Certification

When you use this product in South Korea, observe the following precautions.

사 용 자 안 내 문

이 기기는 업무용 환경에서 사용할 목적으로 적합성평가를 받은 기기로서 가정용 환경에서 사용하는 경우 전파간섭의 우려가 있습니다.

This product meets the electromagnetic compatibility requirements for business use. There is a risk of radio interference when this product is used in home.

Software Licenses and Copyrights

This product incorporates certain third party software. The license and copyright information associated with this software is available at http://www.fa.omron.co.jp/nj_info_e/.

Unit Versions

This section describes the notation that is used for unit versions, the confirmation method for unit versions, and the relationship between unit versions and Support Software versions.

Unit Versions

A “unit version” has been introduced to manage the Units in the NX Series according to differences in functionality accompanying Unit upgrades.

An example is provided below for Communications Coupler Units and NX Units. For the notation that is used for the unit versions of CPU Units or Industrial PCs and the confirmation method for unit versions, refer to the user’s manual for each Unit.

Notation of Unit Versions on Products

The unit version is given with the Unit specifications on the side of the Unit or in the notched area.

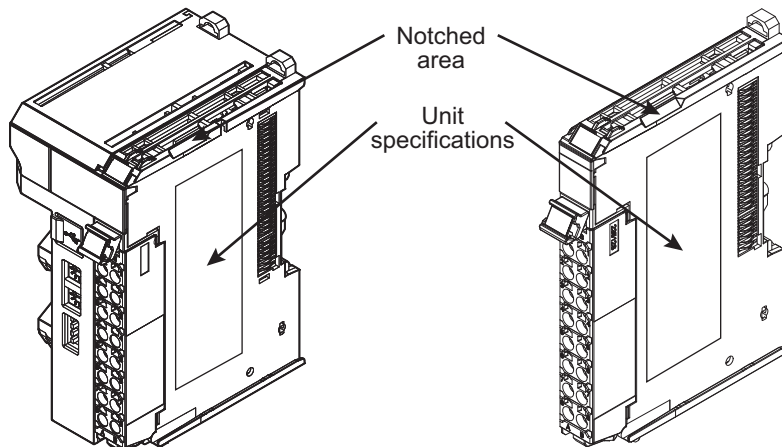

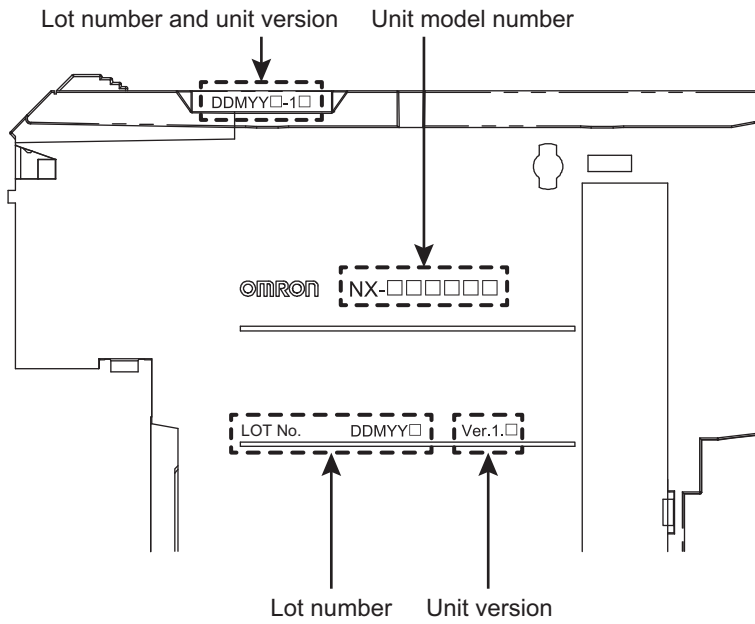

The following information is provided in the Unit specifications on the Unit.

Name	Function
Unit model number	Gives the model of the Unit.
Unit version	Gives the unit version of the Unit.
Lot number	Gives the lot number of the Unit. DDMY□: Lot number, □: Used by OMRON. “M” gives the month (1 to 9: January to September, X: October, Y: November, Z: December)

The following information is provided in the notched area on the Unit.

Name	Function
Lot number and unit version	Gives the lot number and unit version of the Unit. <ul style="list-style-type: none"> DDMY□: Lot number, □: Used by OMRON. “M” gives the month (1 to 9: January to September, X: October, Y: November, Z: December) 1□: Unit version The decimal portion of the unit version is omitted. (It is provided in the Unit specifications.)

Confirming Unit Versions with the Support Software

If your NX Unit is connected to a CPU Unit, refer to the user’s manual of the connected CPU Unit for the confirmation method for the unit version of the NX Unit.

If your NX Unit is connected to a Communications Coupler Unit, refer to the user’s manual of the connected Communications Coupler Unit for the confirmation method for the unit version of the Communications Coupler Unit and NX Unit.

Unit Versions and Support Software Versions

The functions that are supported depend on the unit version of the Unit. The version of Support Software that supports the functions that were added for an upgrade is required to use those functions. Refer to *A-6 Version Information with CPU Units* on page A-51 or *A-7 Version Information with Communications Coupler Units* on page A-52 for the functions that are supported by each Unit version.

Related Manuals

The following table shows related manuals. Use these manuals for reference.

Manual name	Cat. No.	Model	Application	Description
NX-series Analog I/O Units User's Manual for High-speed Analog Input Units	W592	NX-HAD□□□	Learning how to use NX-series High-speed Analog Input Units	The hardware, setup methods, and functions of the NX-series High-speed Analog Input Units are described.
NX-series Data Reference Manual	W525	NX-□□□□□□	Referencing lists of the data that is required to configure systems with NX-series Units.	Lists of the power consumptions, weights, and other NX Unit data that is required to configure systems with NX-series Units are provided.
NX-series System Units User's Manual	W523	NX-PD1□□□ NX-PF0□□□ NX-PC0□□□ NX-TBX01	Learning how to use NX-series System Units.	The hardware and functions of the NX-series System Units are described.
Sysmac Studio Version 1 Operation Manual	W504	SYSMAC -SE2□□□	Learning about the operating procedures and functions of the Sysmac Studio.	Describes the operating procedures of the Sysmac Studio.
Sysmac Library User's Manual for High-speed Analog Inspection Library	W607	SYSMAC-XR016	Learning the function block specifications in the High-speed Analog Inspection Library.	Information required to use the High-speed Analog Inspection Library is described.
NJ/NX-series Troubleshooting Manual	W503	NX701-□□□□ NX502-□□□□ NX102-□□□□ NX1P2-□□□□ NJ501-□□□□ NJ301-□□□□ NJ101-□□□□	Learning about the errors that may be detected in an NJ/NX-series Controller.	Concepts on managing errors that may be detected in an NJ/NX-series Controller and information on individual errors are described.
NY-series Troubleshooting Manual	W564	NY532-□□□□ NY512-□□□□	Learning about the errors that may be detected in an NY-series Industrial PC.	Concepts on managing errors that may be detected in an NY-series Controller and information on individual errors are described.
NX-series EtherCAT® Coupler Unit User's Manual	W519	NX-ECC□□□	Learning how to use the NX-series EtherCAT Coupler Unit and EtherCAT Slave Terminals.	The following items are described: the overall system and configuration methods of an EtherCAT Slave Terminal (which consists of an NX-series EtherCAT Coupler Unit and NX Units), and information on hardware, setup, and functions to set up, control, and monitor NX Units through EtherCAT.

Manual name	Cat. No.	Model	Application	Description
NX-series CPU Unit Hardware User's Manual	W535	NX701-□□□□	Learning the basic specifications of the NX701 CPU Units, including introductory information, designing, installation, and maintenance. Mainly hardware information is provided.	An introduction to the entire NX701 system is provided along with the following information on the CPU Unit. <ul style="list-style-type: none"> • Features and system configuration • Introduction • Part names and functions • General specifications • Installation and wiring • Maintenance and inspection
NX-series NX502 CPU Unit Hardware User's Manual	W629	NX502-□□□□	Learning the basic specifications of the NX502 CPU Units, including introductory information, designing, installation, and maintenance. Mainly hardware information is provided.	An introduction to the entire NX502 system is provided along with the following information on the CPU Unit. <ul style="list-style-type: none"> • Features and system configuration • Introduction • Part names and functions • General specifications • Installation and wiring • Maintenance and inspection
NX-series NX102 CPU Unit Hardware User's Manual	W593	NX102-□□□□	Learning the basic specifications of the NX102 CPU Units, including introductory information, designing, installation, and maintenance. Mainly hardware information is provided.	An introduction to the entire NX102 system is provided along with the following information on the CPU Unit. <ul style="list-style-type: none"> • Features and system configuration • Introduction • Part names and functions • General specifications • Installation and wiring • Maintenance and inspection
NX-series NX1P2 CPU Unit Hardware User's Manual	W578	NX1P2-□□□□	Learning the basic specifications of the NX1P2 CPU Units, including introductory information, designing, installation, and maintenance. Mainly hardware information is provided.	An introduction to the entire NX1P2 system is provided along with the following information on the CPU Unit. <ul style="list-style-type: none"> • Features and system configuration • Introduction • Part names and functions • General specifications • Installation and wiring • Maintenance and inspection

Manual name	Cat. No.	Model	Application	Description
NJ-series CPU Unit Hardware User's Manual	W500	NJ501-□□□□ NJ301-□□□□ NJ101-□□□□	Learning the basic specifications of the NJ-series CPU Units, including introductory information, designing, installation, and maintenance. Mainly hardware information is provided.	An introduction to the entire NJ-series system is provided along with the following information on the CPU Unit. <ul style="list-style-type: none"> • Features and system configuration • Introduction • Part names and functions • General specifications • Installation and wiring • Maintenance and inspection
NY-series IPC Machine Controller Industrial Panel PC Hardware User's Manual	W557	NY532-□□□□	Learning the basic specifications of the NY-series Industrial Panel PCs, including introductory information, designing, installation, and maintenance. Mainly hardware information is provided.	An introduction to the entire NY-series system is provided along with the following information on the Industrial Panel PC. <ul style="list-style-type: none"> • Features and system configuration • Introduction • Part names and functions • General specifications • Installation and wiring • Maintenance and inspection
NY-series IPC Machine Controller Industrial Box PC Hardware User's Manual	W556	NY512-□□□□	Learning the basic specifications of the NY-series Industrial Box PCs, including introductory information, designing, installation, and maintenance. Mainly hardware information is provided.	An introduction to the entire NY-series system is provided along with the following information on the Industrial Box PC. <ul style="list-style-type: none"> • Features and system configuration • Introduction • Part names and functions • General specifications • Installation and wiring • Maintenance and inspection
NJ/NX-series CPU Unit Software User's Manual	W501	NX701-□□□□ NX502-□□□□ NX102-□□□□ NX1P2-□□□□ NJ501-□□□□ NJ301-□□□□ NJ101-□□□□	Learning how to program and set up an NJ/NX-series CPU Unit. Mainly software information is provided.	The following information is provided on a Controller built with an NJ/NX-series CPU Unit. <ul style="list-style-type: none"> • CPU Unit operation • CPU Unit features • Initial settings • Programming based on IEC 61131-3 language specifications
NY-series IPC Machine Controller Industrial Panel PC / Industrial Box PC Software User's Manual	W558	NY532-□□□□ NY512-□□□□	Learning how to program and set up the Controller functions of an NY-series Industrial PC.	The following information is provided on the NY-series Controller functions. <ul style="list-style-type: none"> • Controller operation • Controller features • Controller settings • Programming based on IEC 61131-3 language specifications

Manual name	Cat. No.	Model	Application	Description
NJ/NX-series CPU Unit Built-in EtherCAT® Port User's Manual	W505	NX701-□□□□ NX502-□□□□ NX102-□□□□ NX1P2-□□□□ NJ501-□□□□ NJ301-□□□□ NJ101-□□□□	Using the built-in EtherCAT port on an NJ/NX-series CPU Unit.	Information on the built-in EtherCAT port is provided. This manual provides an introduction and provides information on the configuration, features, and setup.
NY-series IPC Machine Controller Industrial Panel PC / Industrial Box PC Built-in EtherCAT® Port User's Manual	W562	NY532-□□□□ NY512-□□□□	Using the built-in EtherCAT port in an NY-series Industrial PC.	Information on the built-in EtherCAT port is provided. This manual provides an introduction and provides information on the configuration, features, and setup.
NJ/NX-series Instructions Reference Manual	W502	NX701-□□□□ NX502-□□□□ NX102-□□□□ NX1P2-□□□□ NJ501-□□□□ NJ301-□□□□ NJ101-□□□□	Learning detailed specifications on the basic instructions of an NJ/NX-series CPU Unit.	The instructions in the instruction set (IEC 61131-3 specifications) are described.
NY-series Instructions Reference Manual	W560	NY532-□□□□ NY512-□□□□	Learning detailed specifications on the basic instructions of an NY-series Industrial PC.	The instructions in the instruction set (IEC 61131-3 specifications) are described.

Terminology

Term	Abbreviation	Description
CPU Rack	---	A rack to which a CPU Unit is mounted. For NX-series CPU Units to which NX Units can be connected, a CPU Rack has a CPU Unit with NX Units and an End Cover mounted to it.
DC time	---	In a CPU Rack of a NX-series CPU Unit to which NX Units can be connected, time indicated by the clock shared between the CPU Unit and the NX Units. EtherCAT slaves that support distributed clock synchronization have a clock that is shared by all slaves in the network. The time that is based on this distributed clock is called the DC time. The same clock is shared by a CPU Unit, NX Units connected to the CPU Unit, and applicable EtherCAT slaves.
EtherCAT slave information	ESI	An XML file that contains setting information for an EtherCAT slave. Refer to <i>1-2-2 System Configuration of Slave Terminals</i> on page 1-6 for details.
I/O port	---	A logical interface that is used by the NJ/NX-series CPU Unit or NY-series Industrial PC to exchange data with an external device (slave or Unit).
I/O refreshing	---	Cyclic data exchange with external devices that is performed with predetermined memory addresses. Refer to <i>Section 5 I/O Refreshing</i> on page 5-1 for details.
NX bus	---	The NX-series internal bus.
NX message communications	---	Message communications to access NX objects.
PDO communications	---	An acronym for process data communications.
SDO communications	---	One type of EtherCAT communications in which service data objects (SDOs) are used to transmit information whenever required. Refer to the user's manual for the built-in EtherCAT port on the connected CPU Unit or Industrial PC for details.
Sync0	---	A signal that gives the interrupt timing based on the distributed clock (DC) in EtherCAT communications. The slaves execute controls according to this interrupt timing. Refer to the <i>NX-series EtherCAT Coupler Units User's Manual (Cat. No. W519)</i> for details.
Analog Input Time Stamp	---	The DC time at which AD conversion starts in the first sampling of analog input data during each task period in an NX-series High-speed Analog Input Unit. The timing of starting the AD conversion is the same for all channels. Refer to <i>Analog Input Time Stamp</i> on page 7-7 for details.
index	---	Address of an object within an application process.
object	---	An abstract representation of a particular component within a device, which consists of data, parameters, and methods.
differential input	---	A method of reading the difference between a positive analog output signal and a negative analog output signal, which are input to the Unit from the output device.
subindex	---	Sub-address of an object within the object dictionary.
sampling period	---	The period during which the sampling of analog input data is performed in an NX-series High-speed Analog Input Unit.
single-ended input	---	A method of reading the difference between the ground and a positive analog output signal, which is input to the Unit from the output device.

Term	Abbreviation	Description
Slave Terminal	---	A building-block remote I/O terminal, which consists of a Communication Coupler Unit connected with NX Units.
task period	---	The interval at which the primary periodic task or a periodic task is executed. Refer to the software user's manual for the connected CPU Unit or Industrial PC for details.
Communications Coupler Units	---	The generic name of an interface unit for remote I/O communications on a network between NX Units and a host network master.
Digital Filter Processing Period	---	The period during which the processing of the digital low-pass filter and moving average filters is executed.
Trigger Input Time Stamp	---	The DC time at which the trigger input changes from OFF to ON during the NX bus I/O refresh cycle of an NX-series High-speed Analog Input Unit. If the trigger input changes from OFF to ON more than once during the cycle, the DC time at the first change is recorded. Refer to <i>Ch 7 Trigger Input Time Stamp</i> on page 7-8 for details.
primary periodic task	---	The task with the highest priority. Refer to the software user's manual for the connected CPU Unit or Industrial PC for details.
process data	---	Collection of application objects designated to be transferred cyclically or acyclically for the purpose of measurement and control.
process data object	PDO	A structure that describes the mappings of parameters that have one or more process data entities.
process data communications	---	One type of EtherCAT communications in which process data objects (PDOs) are used to exchange information cyclically and in realtime. This is also called PDO communications.

Revision History

A manual revision code appears as a suffix to the catalog number on the front and back covers of the manual.

Cat. No.	W592-E1-04
-----------------	-------------------

↑
Revision code

Revision code	Date	Revised content
01	May 2018	Original production
02	April 2019	<ul style="list-style-type: none">• Made revisions accompanying the appearance change of the indicators.• Corrected mistakes.
03	July 2019	Corrected mistakes.
04	October 2025	Corrected mistakes.

1

Features and System Configuration

This section provides an overview of features, system configurations, unit models and functions of the NX-series High-speed Analog Input Units, as well as relevant support software.

1-1	Features	1-2
1-2	System Configuration	1-5
1-2-1	System Configuration in the Case of a CPU Unit	1-5
1-2-2	System Configuration of Slave Terminals	1-6
1-2-3	Example of Application System Configuration	1-7
1-3	Model	1-9
1-3-1	Model Notation	1-9
1-3-2	Model List	1-9
1-4	List of Functions	1-11
1-5	Support Software	1-12

1-1 Features

The High-speed Analog Input Units are used to process analog input signals and trigger input signals. The NX-series High-speed Analog Input Units have the following features.

Refer to *1-3 Model* on page 1-9 for details on High-speed Analog Input Unit models and *1-4 List of Functions* on page 1-11 for details on their functions.

Sampling Period of 5 μ s at the Shortest

The High-speed Analog Input Units can perform sampling in a sampling period of 5 μ s at the shortest, independent of the Controller's task period.

You can change the sampling period by setting the number of samplings.

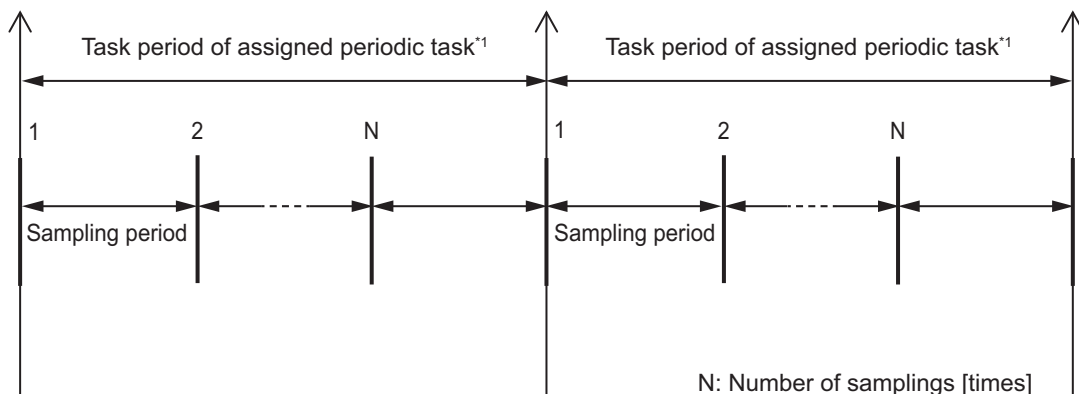

*1. The primary periodic task or the priority-5 periodic task should be assigned. If any other periodic task is assigned, the Unit does not perform sampling correctly.

Sampling Independent of the Number of Channels in Use

The High-speed Analog Input Units perform AD conversion in parallel for each channel that is in use. This enables a sampling period of 5 μ s at the shortest for each channel, independent of the number of channels.

Easy Comparison of Analog Input Data between Channels

For channels that use the same number of samplings, the High-speed Analog Input Units can obtain analog input values of each channel at the same timing. This enables easy comparison of analog input data between the channels.

Improved Environmental Resistance by Individually Isolated Channels

The analog input channels of the High-speed Analog Input Units are individually isolated. This suppresses the fluctuations of analog input values due to interference between channels.

Identification of Analog Input Values with Trigger Input

Both trigger input signals and analog input signals have time information. Based on their time information, you can identify the analog input value that was read at the time of the trigger input. This enables you to efficiently obtain the required analog input data.

Can be Connected to a CPU Unit or Communications Coupler Unit

NX Units NX-series High-speed Analog Input Units can be connected to the following Units.

- NX-series CPU Unit*1
- NX-series Communications Coupler Unit*2

When a CPU Unit and a Communications Coupler Unit are used together, you can unify the methods for installing, wiring, and setting up NX Units, and eventually reduce design costs.

Example:

NX-series NX102 CPU Unit

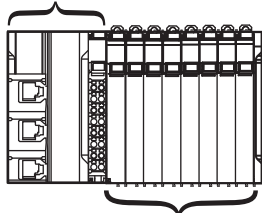

NX Units: NX-series High-speed Analog Input Units

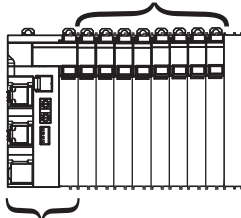

NX-series EtherCAT Coupler Unit

*1. For whether NX Units can be connected to the CPU Unit to be used, refer to the user's manual for the CPU Unit to be used.

*2. The High-speed Analog Input Units can be connected only to an EtherCAT Coupler Unit.

Synchronous I/O with Refresh Cycle of the NX Bus

When the NX-series CPU Unit or EtherCAT Coupler Unit is used together with NX Units that support synchronous I/O refreshing, the I/O control of multiple NX Units can be synchronized at the time to synchronize with the refresh cycle of the NX bus.

This provides an accurate I/O control because it suppresses jitter in the I/O timing of multiple NX Units.

Simple I/O Wiring with a Screwless Clamping Terminal Block

The terminal block is a screwless clamping terminal block.

You can connect the wires simply by pushing the ferrules into the terminals. The amount of wiring work is reduced without requiring the use of screws.

Stable Measurement with Digital Filtering

You can use digital filtering to suppress fluctuations of analog input values that are caused by electrical noise, and provide stable measurements. You can freely combine the following three digital filters for use.

- Digital low-pass filter
- Moving average filter 1
- Moving average filter 2

Designing Digital Filters with Ease

You can use a library of the Sysmac Library to sample and record analog input values before and after digital filtering.

By referring to the recorded results, you can identify the noise frequency band and confirm the noise removal effect to design digital filters easily.

1-2 System Configuration

NX Units NX-series High-speed Analog Input Units can be connected to the following Units.

- NX-series CPU Unit
- NX-series Communications Coupler Unit

The following explains the system configuration for each NX Unit connection destination.

The system configuration for each NX Unit connection destination is provided, and followed by an example of an application system configuration where an NX-series High-speed Analog Input Unit is used.

1-2-1 System Configuration in the Case of a CPU Unit

The following figure shows a system configuration when a group of NX Units is used with an NX-series NX102 CPU Unit. Refer to the user's manual for the connected CPU Unit for information on how to configure the system when a CPU Unit other than the NX102 CPU Unit is used.

You can connect the EtherCAT Slave Terminal to the built-in EtherCAT port on the CPU Unit.

Refer to *1-2-2 System Configuration of Slave Terminals* on page 1-6 for details on the system configuration of a Slave Terminal.

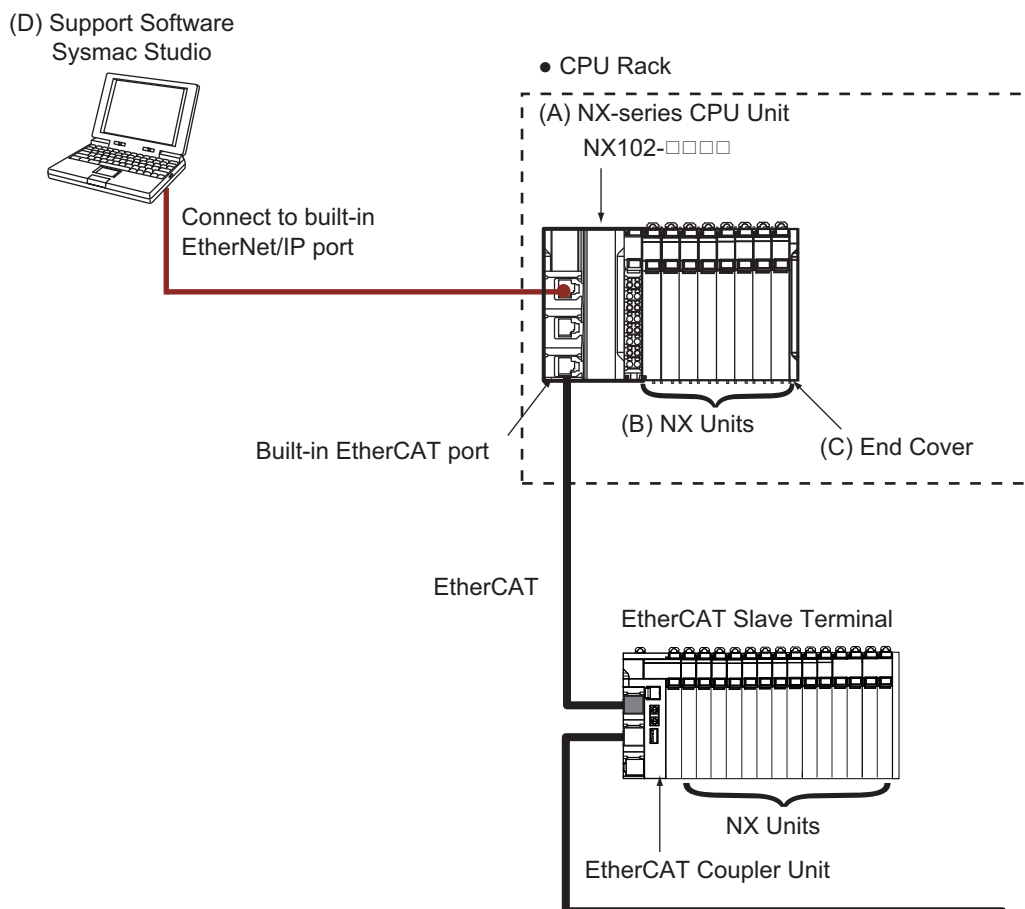

Letter	Item	Description
(A)	NX-series CPU Unit	The Unit that serves as the center of control for a Machine Automation Controller. It executes tasks, refreshes I/O for other Units and slaves, etc. NX Units can be connected to an NX102 CPU Unit.
(B)	NX Units	The NX Units perform I/O processing with connected external devices. The NX Units exchange data with the CPU Unit through I/O refreshing. A maximum of 32 NX Units can be connected to an NX102 CPU Unit.
(C)	End Cover	The End Cover is attached to the end of the CPU Rack.
(D)	Support Software (Sysmac Studio)	A computer software application for setting, programming, debugging, and troubleshooting NJ/NX/NY-series Controllers. For an NX102 CPU Unit, this application performs setting operation by making a connection to a built-in EtherNet/IP port.

1-2-2 System Configuration of Slave Terminals

A building-block remote I/O slave provided with a group of NX Units connected to a Communications Coupler Unit is generically called a Slave Terminal.

The NX Units can be flexibly combined with a Communications Coupler Unit to achieve the optimum remote I/O slave for the application with less wiring, less work, and less space.

EtherCAT Coupler Unit is the only Communications Coupler Unit that can be connected to the High-speed Analog Input Units. Other Communications Coupler Units cannot be connected.

The following figure shows an example of the system configuration when an EtherCAT Coupler Unit is used as a Communications Coupler Unit.

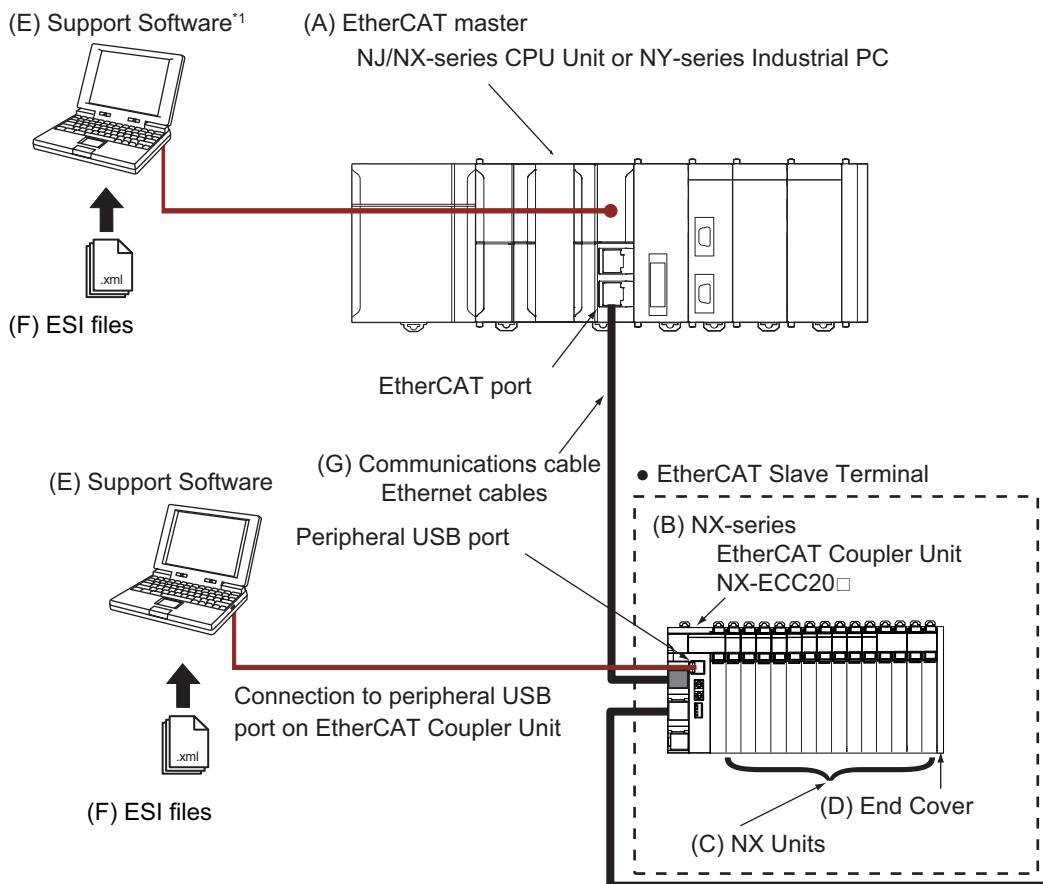

*1. The connection method for the Support Software depends on the model of the CPU Unit or Industrial PC.

Letter	Item	Description
(A)	EtherCAT master*1	The EtherCAT master manages the network, monitors the status of slaves, and exchanges I/O data with slaves. The High-speed Analog Input Units can be connected with the following OMRON master products. <ul style="list-style-type: none"> • NJ/NX-series CPU Units • NY-series Industrial PCs (NX5□□-1□00 and NY5□□-5□00) They cannot be connected to other manufacturers' master products, or other OMRON master products.
(B)	EtherCAT Coupler Unit	The EtherCAT Coupler Unit serves as an interface for process data communications on the EtherCAT network between the NX Units and the EtherCAT master. The I/O data for the NX Units is accumulated in the EtherCAT Coupler Unit and then all of the data is exchanged with the EtherCAT master at the same time. The EtherCAT Coupler Unit can also perform message communications (SDO communications) with the EtherCAT master.
(C)	NX Units	The NX Units perform I/O processing with connected external devices. The NX Units perform process data communications with the EtherCAT master through the EtherCAT Coupler Unit.
(D)	End Cover	The End Cover is attached to the end of the Slave Terminal.
(E)	Support Software*2	The Support Software runs on a personal computer and it is used to configure the EtherCAT network and EtherCAT Slave Terminal, and to program, monitor, and troubleshoot the Controllers.
(F)	ESI (EtherCAT Slave Information) file	The ESI file contains information that is unique to the EtherCAT Slave Terminal in XML format. You can load an ESI file into the Support Software to easily allocate Slave Terminal process data and make other settings. The ESI files for OMRON EtherCAT slaves are installed in the Support Software. You can obtain the ESI files for the latest models through the Support Software's automatic update function.
(G)	Communications cable	Use a double-shielded cable with aluminum tape and braiding of Ethernet category 5 (100Base-TX) or higher, and use straight wiring.

*1. An EtherCAT Slave Terminal cannot be connected to any of the OMRON CJ1W-NC□81/□82 Position Control Units even though they can operate as EtherCAT masters.

*2. The term Support Software indicates software that is provided by OMRON.

Refer to 1-5 *Support Software* on page 1-12 for information on Support Software.

1-2-3 Example of Application System Configuration

The following figure shows an example of a characteristic inspection system configuration where an NX-series High-speed Analog Input Unit is used.

The system reads analog input signals to detect abnormal noise, vibration and torque values through the inspection, and determines whether the workpiece operation is acceptable or not.

It uses input from devices such as a photoelectric sensor as trigger input to efficiently obtain the analog input data required for inspection.

In this way, you can configure a system based on a general-purpose Controller and perform characteristics inspection without using special measuring equipment.

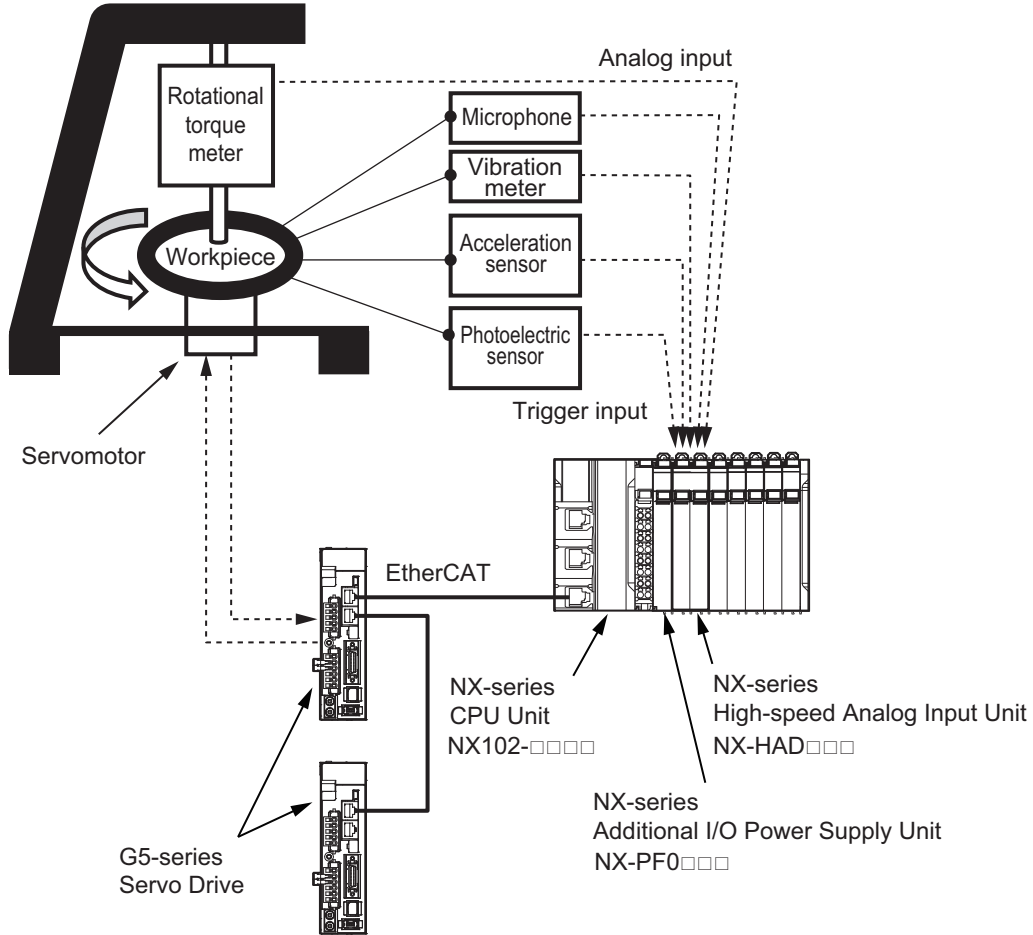

1-3 Model

This section describes the model notation and model list of the High-speed Analog Input Units.

1-3-1 Model Notation

The model numbers of the High-speed Analog Input Units are assigned based on the following rules.

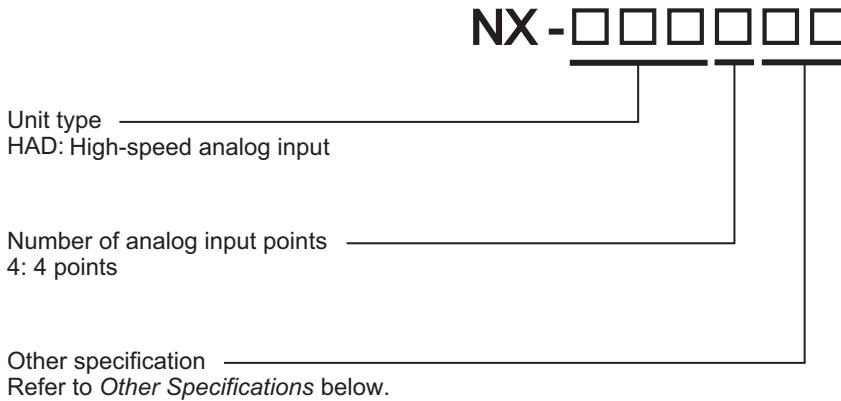

Other Specifications

Number	Analog input section				Trigger input section		I/O refreshing method
	Input range	Resolution	Input method	Conversion time	Number of points	Internal I/O common	
01	<ul style="list-style-type: none"> -10 to 10 V -5 to 5 V 0 to 10 V 0 to 5 V 1 to 5 V 	<ul style="list-style-type: none"> Input range of -10 to 10 V or -5 to 5 V 1/64000 (full scale) Other input ranges 1/32000 (full scale) 	Differential input	5 μs per channel	4 points	NPN	Synchronous I/O refreshing
02	<ul style="list-style-type: none"> 0 to 20 mA 4 to 20 mA 				4 points	PNP	

Refer to *Section 5 I/O Refreshing* on page 5-1 for details on the I/O refreshing method.

1-3-2 Model List

The following table lists the different models of the High-speed Analog Input Units.
For detailed specifications for each Unit, refer to *A-1-2 High-speed Analog Input Units* on page A-3.

Model	Analog input section					Trigger input section		I/O re-freshing method	Reference
	Number of points	Input range	Resolution	Input method	Conversion time	Number of points	Internal I/O common		
NX-HAD401	4 points	<ul style="list-style-type: none"> • -10 to 10 V • -5 to 5 V • 0 to 10 V • 0 to 5 V • 1 to 5 V • 0 to 20 mA • 4 to 20 mA 	*1	Differential input	5 μ s per channel	4 points	NPN	Synchronous I/O refreshing	page A-5
NX-HAD402						4 points	PNP		page A-8

*1. Depending on the input range, the resolution becomes as follows.

- For -10 to 10 V and -5 to 5 V: 1/64000 (full scale)
- For other ranges: 1/32000 (full scale)

1-4 List of Functions

This section describes the High-speed Analog Input Unit functions.

Function name	Description	Reference
Synchronous I/O Refreshing	With this I/O refreshing method, the timing to read inputs or to refresh outputs is synchronized on a fixed interval between more than one NX Unit connected to a CPU Unit. In addition, with this I/O refreshing method, the timing to read inputs or to refresh outputs is synchronized on a fixed interval between more than one NX Unit on more than one Slave Terminal.	5-2-2 <i>Setting the I/O Refreshing Methods</i> on page 5-7
Selecting Channel To Use	This function skips the conversion processing and error detection processing for unused inputs, and reduces the size of I/O data for the Unit.	8-2 <i>Selecting Channel To Use</i> on page 8-4
Input Range Selection	This function sets the input range of analog input.	8-3 <i>Input Range Selection</i> on page 8-6
Number of Samplings Setting	This function sets the number of samplings for analog input data to obtain. The sampling period is determined by the task period of the assigned periodic task and the number of samplings per period.	8-4 <i>Number of Samplings Setting</i> on page 8-8
Digital Filtering	This function uses the digital filter to remove noise components that are contained in analog input signals to suppress the fluctuations of analog input values. You can use the digital low-pass filter and moving average filters.	8-5 <i>Digital Filtering</i> on page 8-18
Input Disconnection Detection	This function detects disconnections of the analog input signal lines. It detects disconnections only when the input range is 1 to 5 V or 4 to 20 mA.	8-6 <i>Input Disconnection Detection</i> on page 8-29
Over Range/Under Range Detection	This function detects when the analog input signal exceeds the range for which conversion is possible.	8-7 <i>Over Range/Under Range Detection</i> on page 8-31
User Calibration	This function corrects offsets in the converted values that occur due to the deterioration of the NX Units and calibrate the Units.	8-8 <i>User Calibration</i> on page 8-33
Zero Set/Zero Reset	The zero set function corrects the analog input value to be the zero point at a desired time. The zero reset function resets the correction that is performed with the zero set function.	8-9 <i>Zero Set/Reset</i> on page 8-38
Trigger Input	This function obtains the input value of the digital input signal to trigger analog input signals, and the DC time at which the input changed.	8-10 <i>Trigger Input</i> on page 8-40
Input Filter	This function prevents fluctuations of data and maintains stability when the input bits of digital input signal at the trigger inputs are unstable due to chattering or noise.	8-11 <i>Input Filter</i> on page 8-48

1-5 Support Software

The Support Software that is used depends on the system configuration.

- **Support Software for a System Configured with a CPU Unit**

If your system is configured by connecting an NX Unit to a CPU Unit, the Sysmac Studio is used as the Support Software.

- **Support Software for a System Configured with a Slave Terminal**

If your system is configured by connecting an NX Unit to a Communications Coupler Unit, use different Support Software depending on the connected Communications Coupler Unit. Since the High-speed Analog Input Units can be connected only to an EtherCAT Coupler Unit, the Sysmac Studio is used as the Support Software.

Refer to *A-6 Version Information with CPU Units* on page A-51 or *A-7 Version Information with Communications Coupler Units* on page A-52 for information on the Support Software versions.

2

Specifications and Operating Procedures

This section describes the general specifications and individual specifications of and operating procedures for the High-speed Analog Input Units.

2-1	Specifications	2-2
2-1-1	General Specifications	2-2
2-1-2	Individual Specifications	2-2
2-2	Operating Procedures	2-3
2-2-1	Overall Procedure	2-3
2-2-2	Detailed Procedure for Configuring the Unit and Creating the User Program.....	2-4

2-1 Specifications

2-1-1 General Specifications

This section provides the general specifications of the High-speed Analog Input Units.

Item		Specification
Enclosure		Mounted in a panel
Grounding methods		Ground of 100 Ω or less
Operating environment	Ambient operating temperature	0 to 55°C
	Ambient operating humidity	10% to 95% (with no condensation or icing)
	Atmosphere	Must be free from corrosive gases.
	Ambient storage temperature	-25 to 70°C (with no condensation or icing)
	Altitude	2,000 m max.
	Pollution degree	2 or less: Conforms to JIS B 3502 and IEC 61131-2.
	Noise immunity	Conforms to IEC 61000-4-4, 2 kV (power supply line)
	Overvoltage category	Category II: Conforms to JIS B 3502 and IEC 61131-2.
	EMC immunity level	Zone B
	Vibration resistance	Conforms to IEC 60068-2-6. 5 to 8.4 Hz with amplitude of 3.5 mm, 8.4 to 150 Hz, acceleration of 9.8 m/s ² 100 min each in X, Y, and Z directions (10 sweeps of 10 min each = 100 min total)
	Shock resistance	Conforms to IEC 60068-2-27, 147 m/s ² , 3 times each in X, Y, and Z directions
Insulation resistance	Refer to the individual specifications of NX Units.	
Dielectric strength	Refer to the individual specifications of NX Units.	
Applicable standards		cULus: Listed (UL61010-2-201), ANSI/ISA 12.12.01, EU: EN 61131-2, RCM, KC (KC Registration), and EAC

Note 1. The specifications of insulation resistance and dielectric strength vary with NX Unit Models.

Note 2. Refer to the OMRON website (www.ia.omron.com) or ask your OMRON representative for the most recent applicable standards for each model.

2-1-2 Individual Specifications

Refer to *A-1 Data Sheet* on page A-2 for the individual specifications of the High-speed Analog Input Units.

2-2 Operating Procedures

This section describes the operating procedures for the High-speed Analog Input Units. First the overall procedure is provided, and then the procedure for configuring the Unit and creating the user program is described in detail.

Refer to the user's manual for the connected CPU Unit or Communications Coupler Unit for details on the operating procedures and how to download the settings of the CPU Unit or Slave Terminal to which the High-speed Analog Input Unit is connected.

2-2-1 Overall Procedure

The following table provides the overall procedure for using the High-speed Analog Input Units.

Procedure	Item	Description	Reference
1	Determining the Target Values	Determine the target values (including the allowable range) for the analog input sampling period.	8-4 <i>Number of Samplings Setting</i> on page 8-8
2	Configuring the Unit and Creating the User Program	Register the High-speed Analog Input Unit with the Support Software. Configure the High-speed Analog Input Unit offline for the functions to use and I/O allocations. In addition, create a user program. The Sysmac Library prepared for the High-speed Analog Input Units is usable in the user program.	<ul style="list-style-type: none"> 2-2-2 <i>Detailed Procedure for Configuring the Unit and Creating the User Program</i> on page 2-4 Software user's manual for the connected CPU Unit or Industrial PC <i>Sysmac Library User's Manual for High-speed Analog Inspection Library (Cat. No. W607)</i>
3	Installing the Unit	Attach the High-speed Analog Input Unit to the CPU Unit or Communications Coupler Unit. There are restrictions on the installation of the Unit. Check these restrictions before you install the Unit.	<i>Section 4 Installation and Wiring</i> on page 4-1
4	Wiring the Unit	Wire the High-speed Analog Input Unit. To use analog current input, prepare a short-circuit cable and connect the applicable terminals.	
5	Downloading the Unit Settings and the User Program	Turn ON the power supply to the CPU Unit or Communications Coupler Unit and download the Unit settings that are made with the Support Software to the High-speed Analog Input Unit. Also download the user program to the NJ/NX-series CPU Unit or NY-series Industrial PC.	<ul style="list-style-type: none"> Software user's manual for the connected CPU Unit User's manual for the connected Communications Coupler Unit
6	Calibrating the Unit	Calibrate the analog inputs of the High-speed Analog Input Unit, as required.	8-8 <i>User Calibration</i> on page 8-33

Pro- ce- dur- e	Item	Description	Reference
7	Checking Operation	Execute the following and check the operation of the High-speed Analog Input Unit. <ul style="list-style-type: none"> • Use the Support Software to check the wiring by reading the analog input values and trigger input values. • Check that the Unit settings and user program are working correctly. • If you use the digital filtering, check that it provides expected filtering effects. 	4-3-3 <i>Checking the Wiring</i> on page 4-21 A-4 <i>Digital Filter Design with the Library</i> on page A-21

2-2-2 Detailed Procedure for Configuring the Unit and Creating the User Program

The detailed procedure for configuring the Unit and creating the user program is shown below. After the flow diagram, each step in the flow is described.

Operation Flow

The operation flow is shown below.

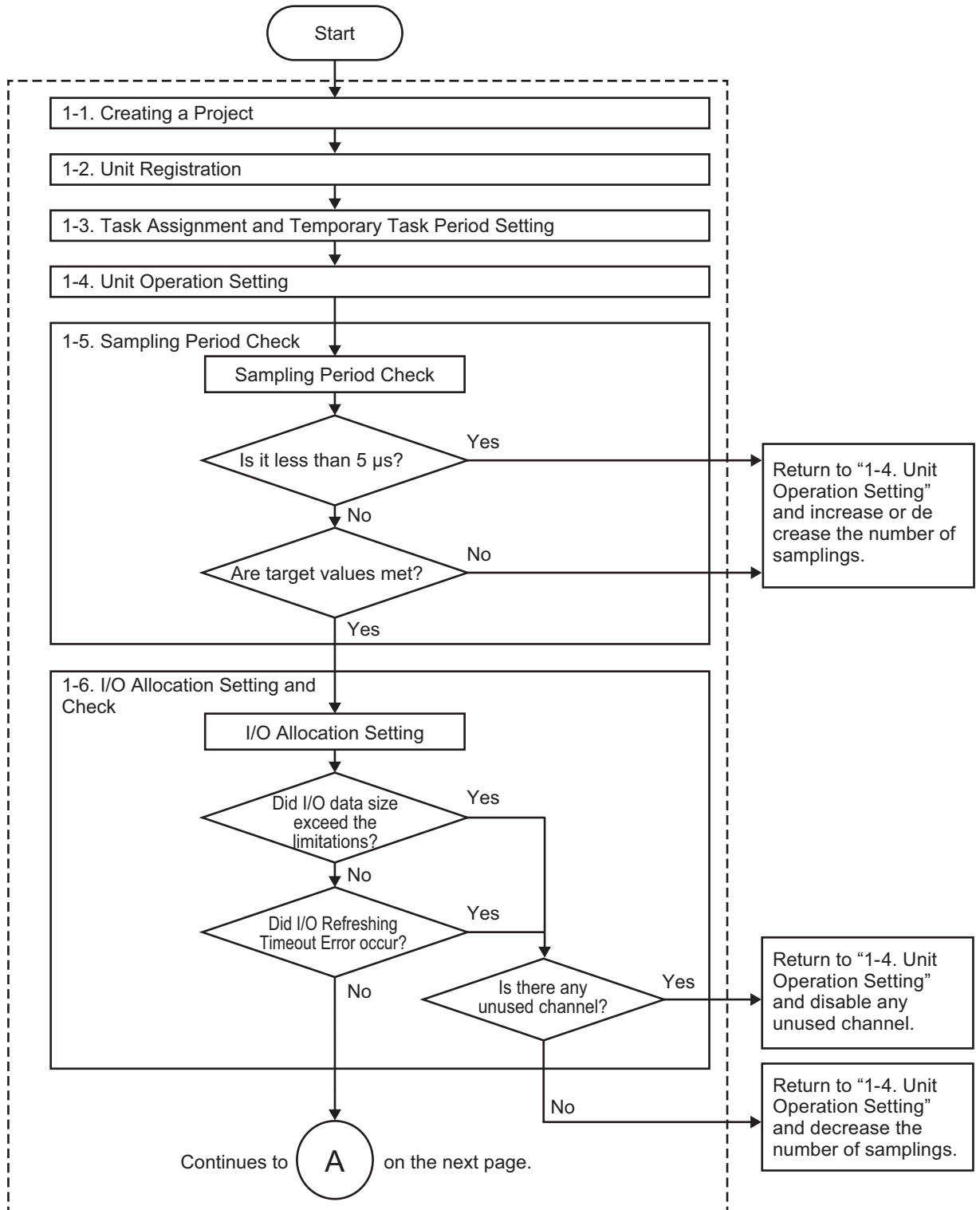

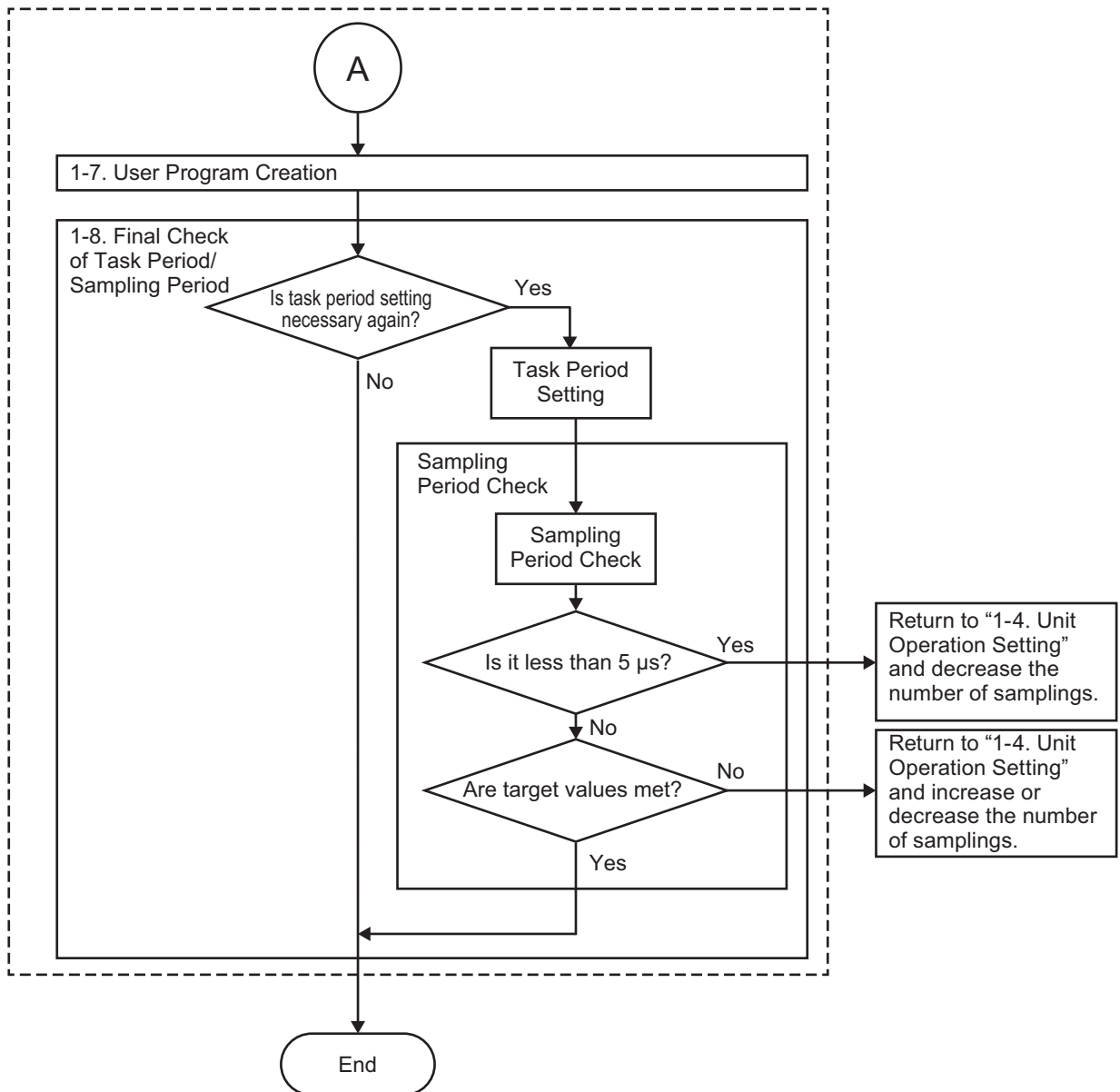

Description of Each Step

The following table describes each step in the operation flow and shows where references are provided.

Step	Item	Description	Reference
1-1	Project Creation	Create a project with the Support Software.	Operation manual for the Support Software that you are using
1-2	Unit Registration	Register the High-speed Analog Input Unit offline in the connected CPU Unit or Communications Coupler Unit.	

Step	Item	Description	Reference
1-3	Task Assignment and Temporary Task Period Setting	Temporarily configure the task settings with the task period for the CPU Unit or Communications Coupler Unit to which the High-speed Analog Input Unit is connected. When you use the High-speed Analog Input Unit, assign the primary periodic task or the priority-5 periodic task. If any other periodic task is assigned, the Unit does not perform sampling correctly.	Software user's manual for the connected CPU Unit
1-4	Unit Operation Setting	Set the following functions in the Unit operation settings. <ul style="list-style-type: none"> • Selecting Channel To Use • Input Range Selection • Number of Samplings Setting • Digital Filtering • Input Disconnection Detection • Input Filter 	<ul style="list-style-type: none"> • <i>8-2 Selecting Channel To Use</i> on page 8-4 • <i>8-3 Input Range Selection</i> on page 8-6 • <i>8-4 Number of Samplings Setting</i> on page 8-8 • <i>8-5 Digital Filtering</i> on page 8-18 • <i>8-6 Input Disconnection Detection</i> on page 8-29 • <i>8-11 Input Filter</i> on page 8-48
1-5	Sampling Period Check	In the Edit I/O Allocation Settings Window, check that the sampling period meets the following conditions: <ul style="list-style-type: none"> • It is 5 μs or longer. • The target values are met. 	<i>8-4 Number of Samplings Setting</i> on page 8-8
1-6	I/O Allocation Setting and Check	Click the Update I/O Entry Button in the Edit I/O Allocation Settings Window. When you click this button, the High-speed Analog Input Unit automatically allocates the required I/O data. If an I/O entry that matches the set values of the Unit operation settings has been set, you cannot click the button. After completion of the settings, check with the Support Software that the following conditions are met: <ul style="list-style-type: none"> • The limitations on the I/O data size are not exceeded.*1 • No I/O Refreshing Timeout Error occurred.*2 	<i>7-2 Setting I/O Allocations with the Sysmac Studio</i> on page 7-14
1-7	User Program Creation	Create the user program. The Sysmac Library prepared for the High-speed Analog Input Units is usable in the user program.	<ul style="list-style-type: none"> • Software user's manual for the connected CPU Unit or Industrial PC • <i>Sysmac Library User's Manual for High-speed Analog Inspection Library</i> (Cat. No. W607)

Step	Item	Description	Reference
1-8	Final Check of Task Period/Sampling Period	<p>Check whether or not you need to set a task period again, since the task period may need to be changed depending on the size of the user program.</p> <p>To change the task period, you need to set a task period again. After completion of the setting, perform the final check of the sampling period on the Sampling Settings and Digital Filter Settings Tab Page. If you change the task period or a Unit operation setting on the Digital Filter Settings Tab Page, the change is immediately reflected on the sampling period value.</p>	<ul style="list-style-type: none"> • Software user's manual for the connected CPU Unit • 8-4-4 <i>Checking the Sampling Settings</i> on page 8-11

- *1. To connect to the CPU Unit, check this on the CPU and Expansion Racks Tab Page. To connect to the Communications Coupler Unit, check this on the Edit Slave Terminal Configuration Tab Page.
- *2. Check this on the Multi-view Explorer.



Precautions for Correct Use

- For the High-speed Analog Input Units, it takes time until the NX Unit I/O Data Active Status changes to TRUE when power is turned ON or the Unit is restarted. When you write the program, make sure that the Unit always checks if the NX Unit I/O Data Active Status has changed to TRUE before it starts operation.
Refer to the software user's manual for the connected CPU Unit or the user's manual for the connected EtherCAT Coupler Unit for information on the NX Unit I/O Data Active Status.
- When you use an NX-series High-speed Analog Input Unit in the CPU Rack or Slave Terminal, the primary periodic task or the priority-5 periodic task should be assigned. If any other periodic task is assigned, the Unit does not perform sampling correctly.
When any other periodic task is assigned, the High-speed Analog Input Units do not perform sampling throughout the task period. They perform sampling only during a part of the task period. Note that the Sysmac Studio does not display a correct sampling period on the Edit I/O Allocation Settings Window and the Sampling Settings and Digital Filter Settings Tab Page.

3

Part Names and Functions

This section describes the names and functions of the parts of the High-speed Analog Input Units.

3-1	Part Names	3-2
3-2	Indicators	3-3
3-2-1	TS Indicator	3-3
3-2-2	IN Indicator	3-4
3-2-3	Appearance Change of the Indicators	3-5
3-3	Terminal Blocks	3-6

3-1 Part Names

This section describes the names and functions of the parts of the High-speed Analog Input Units.

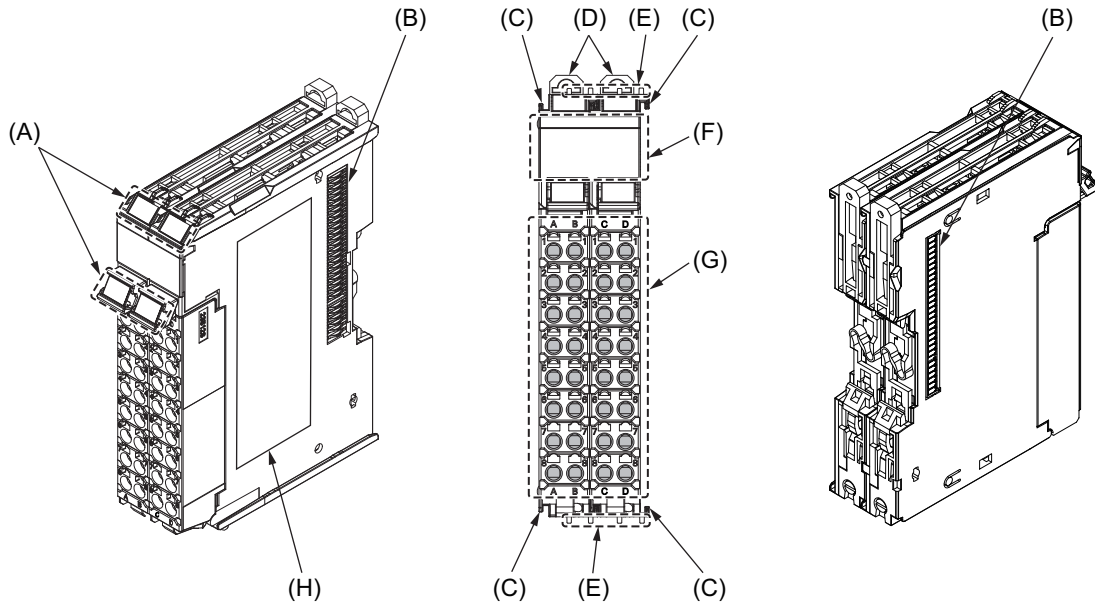

Letter	Name	Description
(A)	Marker attachment locations	The locations where markers are attached. The markers made by OMRON are installed for the factory setting. Commercially available markers can also be installed.
(B)	NX bus connector	This connector is used to connect each Unit.
(C)	Unit hookup guides	These guides are used to connect two Units.
(D)	DIN Track mounting hooks	These hooks are used to mount the NX Unit to a DIN Track.
(E)	Protrusions for removing the Unit	The protrusions to hold when removing the Unit.
(F)	Indicators	The indicators show the current operating status of the Unit.
(G)	Terminal block	The terminal block is used to connect external devices.
(H)	Unit specifications	The specifications of the Unit are given.

Refer to *Installation* in the hardware user's manual for the connected CPU Unit or the user's manual for the Communications Coupler Unit for details on attaching markers.

Refer to 3-2 *Indicators* on page 3-3 for details on the indicators.

Refer to 3-3 *Terminal Blocks* on page 3-6 for details on the terminal blocks.

3-2 Indicators

The High-speed Analog Input Units have indicators that show the current operating status of the Unit. This section describes the names and functions of the indicators.

The appearance of the indicators has been changed for models released in or before March 2019 with lot numbers that represent the date of or after March 20, 2019. In this manual, those models are shown with the indicators after the appearance change.

For details on the applicable models and the changes, refer to 3-2-3 *Appearance Change of the Indicators* on page 3-5.

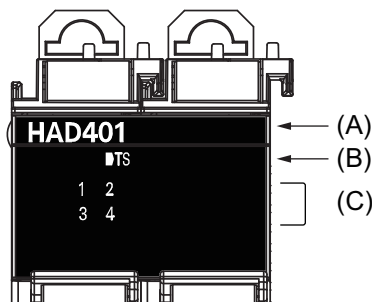

24 mm width



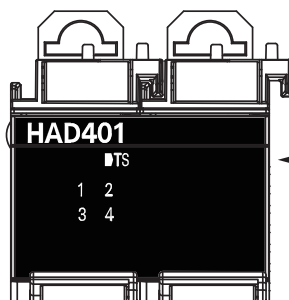

Letter	Name	Description
(A)	Model number indication	Gives the model number of the NX Unit, without the prefix. For example, HAD401 is given for the NX-HAD401. The text is orange.
(B)	TS indicator	This indicator shows the current operating status of the High-speed Analog Input Unit and its communications status with the CPU Unit or the Communications Coupler Unit.
(C)	IN indicator	This indicator shows the input status of each trigger input terminal on the High-speed Analog Input Unit.

3-2-1 TS Indicator



24 mm width

This indicator shows the current status of the High-speed Analog Input Unit and its communications status with the CPU Unit or the Communications Coupler Unit.

Color	Status	Description
Green		Lit <ul style="list-style-type: none"> The Unit is operating normally. The Unit is ready for I/O refreshing. I/O checking is operating.*1
		Flashing (at 2-s intervals) <ul style="list-style-type: none"> Initializing Restarting is in progress for the Unit. Downloading
Red		Lit <p>A hardware failure, WDT error, or other fatal error that is common to all I/O Units occurred.</p>
		Flashing (at 1-s intervals) <p>A communications error or other NX bus-related error that is common to all I/O Units occurred.</p>
---		Not lit <ul style="list-style-type: none"> No Unit power supply Restarting is in progress for the Unit. Waiting for initialization to start

*1. Refer to the user's manual for the Communications Coupler Unit for the status of the indicator on the Communications Coupler Units when I/O checking is in progress.

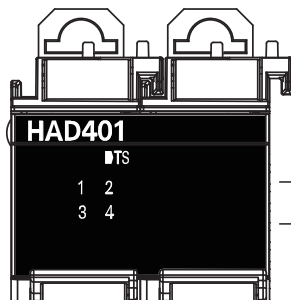

3-2-2 IN Indicator



24 mm width

This indicator shows the input status of each trigger input terminal on the High-speed Analog Input Unit.



The following shows an example of trigger input 1. The trigger input number is lit or not lit.

Color	Status	Description
Yellow		Lit <p>The trigger input corresponding to the number is ON.</p>
---		Not lit <p>The trigger input corresponding to the number is OFF.</p>



Additional Information

Product models before the appearance change have a square-shaped light-emitter on the left side of each trigger input number. For details on the applicable models and the changes, refer to 3-2-3 *Appearance Change of the Indicators* on page 3-5.

Color	Status	Description
Yellow	 Lit	Trigger input is ON.
---	 Not lit	Trigger input is OFF.

3-2-3 Appearance Change of the Indicators

The appearance of the indicators has been changed for models released in or before March 2019 with lot numbers that represent the date of or after March 20, 2019. See below for details on the applicable models and the changes. Models that are not listed here have the appearance after the change.

Applicable Models

NX-HAD401 and NX-HAD402

Change Details

● TS Indicator

The shape of the light emitting part of each indicator has been changed from a square to a pentagon.

See below.



Before change



After change

● IN Indicator

The indicators before the change have a square-shaped light-emitter on the left side of each trigger input number, and the indicators after the change have the trigger input numbers emitting light.

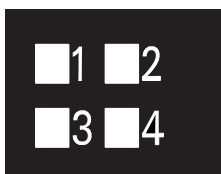

Before change

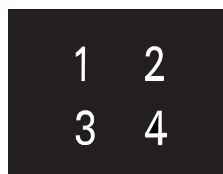

After change

3-3 Terminal Blocks

Screwless clamping terminal blocks are used for the High-speed Analog Input Units for easy wiring and removal.

The compatible terminal blocks for the High-speed Analog Input Units are NX-TBA162 and NX-TBB162.

The NX-TBA162 terminal block is connected to the left side of the Unit and the NX-TBB162 terminal block is connected to the right side of the Unit.

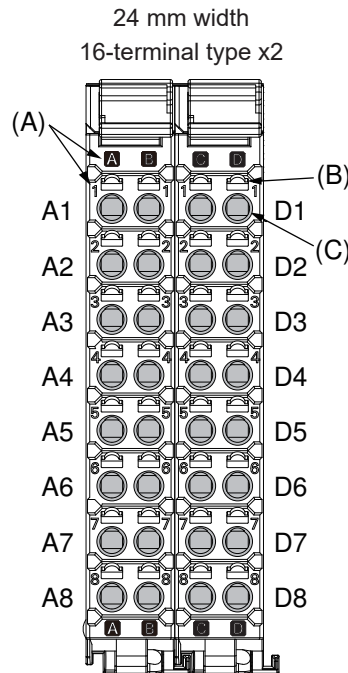

Letter	Name	Description
(A)	Terminal number indications	Terminal numbers for which A to D indicate the column, and 1 to 8 indicate the line are displayed. The terminal number is a combination of column and line, i.e. A1 to A8 and B1 to B8. A1 to A8 and B1 to B8 are terminal number of the left terminal block, C1 to C8 and D1 to D8 are terminal numbers of the right terminal block.
(B)	Release holes	Insert a flat-blade screwdriver into these holes to connect and remove the wires.
(C)	Terminal holes	The wires are inserted into these holes.

4

Installation and Wiring

This section describes how to install the NX Units, the types of power supplies used in the CPU Rack or Slave Terminal, their wiring methods, and how to wire the NX Units.

4

4-1	Installing NX Units.....	4-2
4-1-1	Restriction on Installation Orientation.....	4-2
4-1-2	Restriction on Adjacent Units	4-3
4-2	Power Supply Types and Wiring.....	4-4
4-2-1	Power Supply Types.....	4-4
4-2-2	I/O Power Supply Applications and Methods	4-4
4-2-3	Calculating the Total Current Consumption from I/O Power Supply.....	4-5
4-3	Wiring the Terminals	4-7
4-3-1	Wiring to the Screwless Clamping Terminal Blocks	4-7
4-3-2	Preventing Incorrect Attachment of Terminal Blocks.....	4-17
4-3-3	Checking the Wiring	4-21
4-4	Wiring External Devices	4-22
4-4-1	Terminal Block Arrangement	4-22
4-4-2	Wiring Examples	4-22
4-4-3	Precautions for Wiring	4-25

4-1 Installing NX Units

Refer to *Installation* in the hardware user's manual for the connected CPU Unit or the user's manual for the connected Communications Coupler Unit for information on installing NX Units, including the High-speed Analog Input Units.

This section describes the restrictions on installation which are specific to the High-speed Analog Input Units.



Precautions for Safe Use

- The High-speed Analog Input Units can be used only in the upright orientation. Otherwise, Unit failure or malfunction may occur.
- Do not connect the High-speed Analog Input Units next to a Relay Output Unit. Otherwise, Unit malfunction may occur.

4-1-1 Restriction on Installation Orientation

The High-speed Analog Input Units can be installed only in the upright orientation, regardless of the destination to which they are connected.

Connection to the CPU Unit

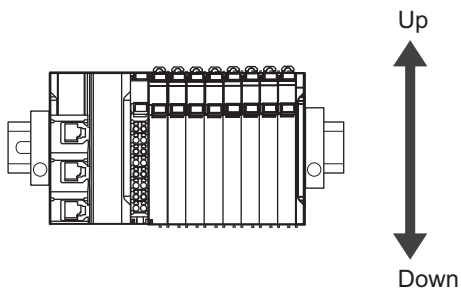

Connection to the Communications Coupler Unit

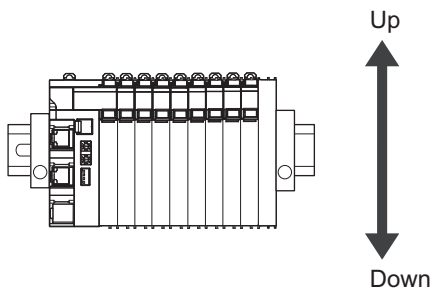

4-1-2 Restriction on Adjacent Units

The following Unit cannot be connected next to a High-speed Analog Input Unit.

- Relay Output Unit (NX-OC□□□□)

NG

NX-series Relay Output Unit (NX-OC □□□□)	NX-series High-speed Analog Input Unit (NX-HAD □□□)	NX-series Relay Output Unit (NX-OC □□□□)
--	--	--

OK

NX-series Relay Output Unit (NX-OC □□□□)	Other NX Unit	NX-series High-speed Analog Input Unit (NX-HAD □□□)	Other NX Unit	NX-series Relay Output Unit (NX-OC □□□□)
--	------------------	--	------------------	--

4-2 Power Supply Types and Wiring

This section describes the power supply types and wiring.

4-2-1 Power Supply Types

There are the following two types of power supplies that supply power to the NX Units.

Power supply name	Description
NX Unit power supply	This power supply is used for operating the NX Units.
I/O power supply	This power supply is used for driving the I/O circuits of the NX Units and for the connected external devices.

The method for supplying power to the NX Units and the wiring method depend on the specifications for the CPU Unit to which NX Units are connected or the specifications for the Slave Terminal. Refer to *Designing the Power Supply System* or *Wiring*, which are described both in the hardware user's manual for the CPU Unit to which NX Units are connected and user's manual for the Communications Coupler Unit, for details on the method for supplying power to the NX Units and the wiring method.

The subsequent sections describe the applications of I/O power supply for the High-speed Analog Input Units and supply methods, and how to calculate the total current consumption from the I/O power supply.

4-2-2 I/O Power Supply Applications and Methods

This section describes the I/O power supply applications and methods for the High-speed Analog Input Units.

I/O Power Supply Applications

The I/O power supply is used for the following applications.

- Operation of the trigger input circuit in the High-speed Analog Input Units
- Input current to the trigger input terminals of the High-speed Analog Input Units
- Power supply for external devices connected to trigger input terminals of the High-speed Analog Input Units

I/O Power Supply Method

Power is supplied by the following method.

● Supply from the NX Bus

Power is supplied through the NX bus connectors by connecting an I/O power supply to the I/O power supply terminals on the Communications Coupler Unit or Additional I/O Power Supply Unit.

Refer to *Designing the Power Supply System* and *Wiring* in the hardware user's manual for the connected CPU Unit for details on Units to which I/O power is supplied in a CPU Rack.

Refer to *Designing the Power Supply System and Wiring* in the user's manual for the connected Communications Coupler Unit for details on Units to which I/O power is supplied in a Slave Terminal.



Additional Information

NX-series Power Supply-related Units

The following three NX-series Units are related to power supply.

- Additional NX Unit Power Supply Units
- Additional I/O Power Supply Units
- I/O Power Supply Connection Units

Refer to *NX-series System Units User's Manual (Cat. No. W523)* for the specifications of these Units.

For a complete list of the latest power supply Units in the NX Series, refer to the product catalog or OMRON website, or contact your OMRON representative.

4-2-3 Calculating the Total Current Consumption from I/O Power Supply

The total current consumption of I/O power supplied from the NX bus must be within the range of the maximum I/O power supply current of the Communications Coupler Unit or the Additional I/O Power Supply Unit. However, when an Additional I/O Power Supply Unit is connected to the CPU Rack of a CPU Unit, the maximum I/O power supply current value may be smaller than that of the Additional I/O Power Supply Unit. For example, the maximum I/O power supply current for the CPU Rack of an NX1P2 CPU Unit is 4 A. Refer to *Maximum I/O Power Supply Current* under *Designing the I/O Power Supply from the NX Bus* in the hardware user's manual for the CPU Unit to which NX Units are connected for the maximum I/O power supply current of the CPU Rack.

To confirm this and to calculate the I/O power supply capacity, calculate the total current consumption of the I/O power supply from the NX bus.

Note that the current consumption from I/O power supply indicated in the data sheet for each Unit type does not include the load current of any external connection load and current consumption of any connected external devices.

The total current consumption from I/O power supply of the High-speed Analog Input Units is calculated as follows:

Refer to *A-1 Data Sheet* on page A-2 for the current consumption from I/O power supply for each High-speed Analog Input Unit model.



Precautions for Safe Use

The I/O power supply current for the CPU Rack with an NX-series CPU Unit should be within the range specified for the CPU Unit model. For example, use the NX1P2 CPU Unit with a current of 4 A or less. Using the currents that are outside of the specifications may cause failure or corruption. Refer to the user's manual for the connected CPU Unit for the I/O power supply current for the CPU Unit model.

Total Current Consumption from I/O Power Supply from the NX Bus

The total current consumption from I/O power supply from the NX bus is the sum of the following: the current consumption from I/O power supply of the NX Unit that supplies the I/O power from the NX

bus, the current consumption of each applicable I/O circuit, and current consumption of any connected external devices.

- Total Current Consumption from I/O Power Supply of the High-speed Analog Input Unit
= (Current consumption from I/O power supply of the High-speed Analog Input Unit) + (Input current to the trigger input terminals × Number of input points used) + (Total current consumption of external devices connected to the trigger input terminals)

4-3 Wiring the Terminals

This section describes how to wire the terminals on the High-speed Analog Input Units.

WARNING

Make sure that the voltages and currents that are input to the Units and slaves are within the specified ranges. Inputting voltages or currents that are outside of the specified ranges may cause accidents or fire.



CAUTION

Be sure that all terminal screws and cable connector screws are tightened to the torque specified in the relevant manuals. The loose screws may result in fire or malfunction.



4-3-1 Wiring to the Screwless Clamping Terminal Blocks

This section describes how to connect wires to the screwless clamping terminal blocks, the installation and removing methods, and functions for preventing incorrect attachment.

You can connect ferrules that are attached to the twisted wires to the screwless clamping terminal block. You can also connect the twisted wires or the solid wires to the screwless clamping terminal block. If you connect the ferrules, all you need to do to connect the wires is to insert the ferrules into the terminal holes.

Wiring Terminals

The terminals to be wired are as follows.

- I/O power supply terminals
- Input terminals

Applicable Wires

You can connect twisted wires, solid wires, or ferrules attached to twisted wires to the screwless clamping terminal block. The applicable wire dimensions and preparation methods are given below.

● Dimensions of Wires Connected to the Terminal Block

The dimensions of wires that you can connect into the terminal holes of the screwless clamping terminal block are as in the figure below.

Process the applicable wires that are specified in the following description to apply the dimensions.

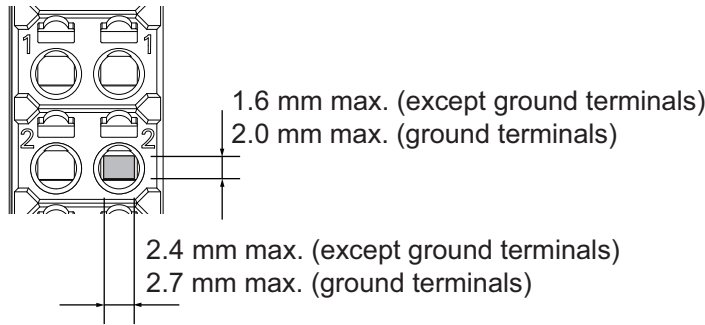

● Using Ferrules

If you use ferrules, attach the twisted wires to them.

Observe the application instructions for your ferrules for the wire stripping length when attaching ferrules.

Always use plated one-pin ferrules. Do not use unplated ferrules or two-pin ferrules.

The applicable ferrules, wires, and crimping tools are given in the following table.

Terminal type	Manufacturer	Ferrule model	Applicable wire (mm ² (AWG))	Crimping tool
All terminals except ground terminals	Phoenix Contact	AI0,34-8	0.34 (#22)	Phoenix Contact (Applicable wire sizes are given in parentheses.) CRIMPFOX 6 (0.25 to 6 mm ² , AWG24 to 10)
		AI0,5-8	0.5 (#20)	
		AI0,5-10		
		AI0,75-8	0.75 (#18)	
		AI0,75-10		
		AI1,0-8	1.0 (#18)	
		AI1,0-10		
		AI1,5-8	1.5 (#16)	
Ground terminals		AI2,5-10	2.0*1	
All terminals except ground terminals	Weidmuller	H0.14/12	0.14 (#26)	Weidmuller (Applicable wire sizes are given in parentheses.) PZ6 Roto (0.14 to 6 mm ² , AWG26 to 10)
		H0.25/12	0.25 (#24)	
		H0.34/12	0.34 (#22)	
		H0.5/14	0.5 (#20)	
		H0.5/16		
		H0.75/14	0.75 (#18)	
		H0.75/16		
		H1.0/14	1.0 (#18)	
		H1.0/16		
		H1.5/14	1.5 (#16)	
	H1.5/16			

*1. For the ferrule type AI2,5-10, use wires with a diameter of 2.0 to 2.1 mm². Wires with a diameter exceeding 2.1 mm² cannot be used with the screwless clamping terminal block.

When you use any ferrules other than those in the above table, crimp them to the twisted wires so that the following processed dimensions are achieved.

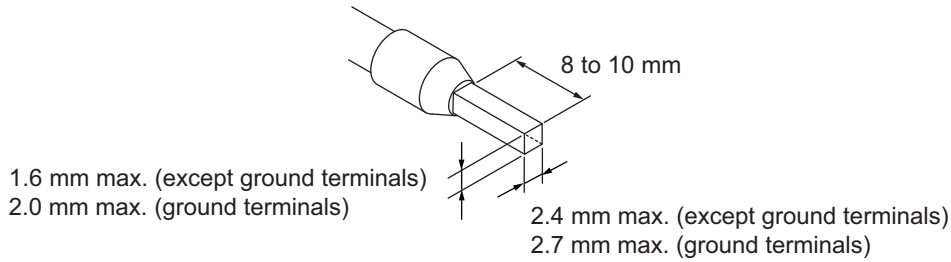

● **Using Twisted or Solid Wires**

If you use twisted wires or solid wires, use the following table to determine the correct wire specifications.

Terminals		Wire type				Wire size	Conductor length (stripping length)
		Twisted wires		Solid wires			
Classification	Current capacity	Plated	Unplated	Plated	Unplated		
All terminals except ground terminals	2 A max.	Possible	Possible	Possible	Possible	0.08 to 1.5 mm ² (AWG28 to 16)	8 to 10 mm
	Greater than 2 A and 4 A or less		Not possible	Possible*1	Not possible		
	Greater than 4 A	Possible*1		Not possible			
Ground terminals	---	Possible	Possible	Possible*2	Possible*2	2.0 mm ²	9 to 10 mm

- *1. Secure wires to the screwless clamping terminal block. Refer to *Securing Wires* on page 4-13 for how to secure wires.
- *2. With the NX-TB□□□1 Terminal Block, use twisted wires to connect the ground terminal. Do not use a solid wire.

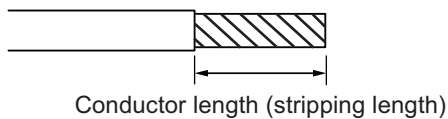



Precautions for Correct Use

- Use cables with suitable wire sizes for the carrying current. There are also restrictions on the current due to the ambient temperature. Refer to the manuals for the cables and use the cables correctly for the operating environment.
- For twisted wires, strip the sheath and twist the conductor portion. Do not unravel or bend the conductor portion of twisted wires or solid wires.

NG

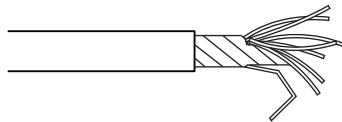

Unravel wires

NG

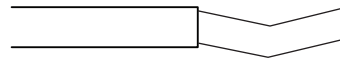

Bend wires



Additional Information

If more than 2 A will flow on the wires, use plated wires or use ferrules.

Connecting and Removing Wires

This section describes how to connect and remove wires.

● **Terminal Block Parts and Names**

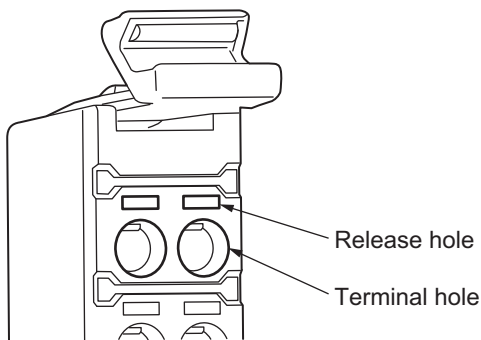

● **Required Tools**

Use a flat-blade screwdriver to connect and remove wires.

Use the following flat-blade screwdriver.

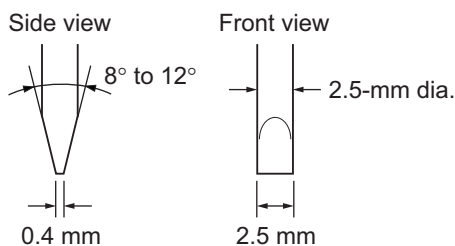

Recommended screwdriver

Model	Manufacturer
SZF 0-0,4X2,5	Phoenix Contact

● Connecting Ferrules

Insert the ferrule straight into the terminal hole.

You do not need to insert a flat-blade screwdriver into the release hole.

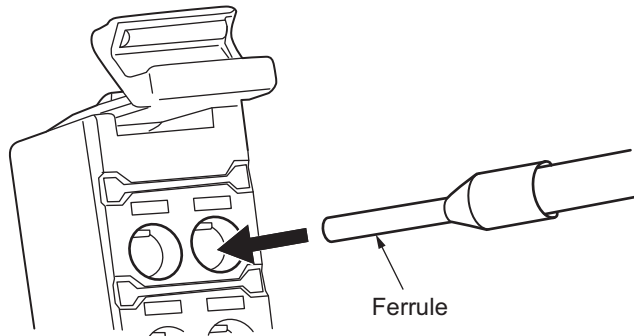

After you make a connection, make sure that the ferrule is securely connected to the terminal block.

● Connecting Twisted Wires or Solid Wires

Use the following procedure to connect the twisted wires or solid wires to the terminal block.

- 1 Press a flat-blade screwdriver diagonally into the release hole.
The optimal angle for insertion is between 10° to 15° . If the screwdriver is inserted correctly, you should feel resistance from the spring inside the release hole.

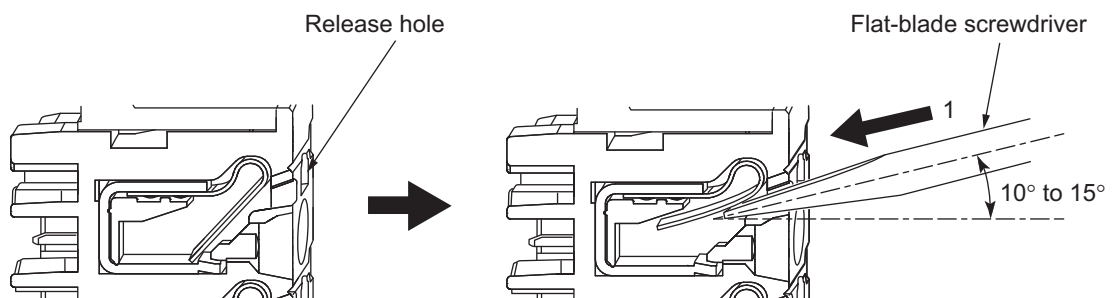

- 2 Leave the flat-blade screwdriver pressed into the release hole and insert the twisted wire or the solid wire into the terminal hole.
Insert the stripped portion of the wire all the way into the terminal hole to prevent shorting.

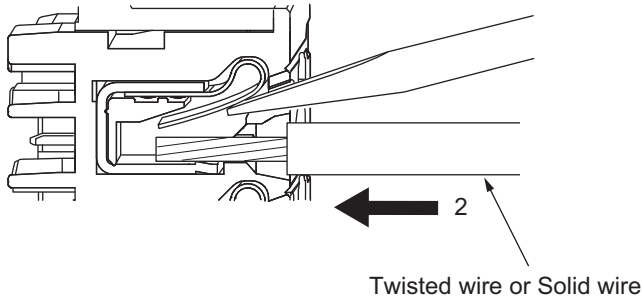

3 Remove the flat-blade screwdriver from the release hole.

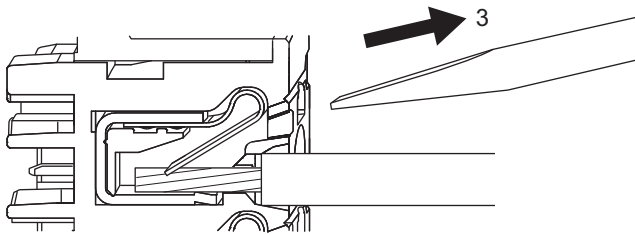

After you make a connection, lightly pull the twisted wire or the solid wire to make sure that the wire is securely connected to the terminal block.



Precautions for Safe Use

- Do not press the flat-blade screwdriver straight into the release holes on a screwless clamping terminal block. Doing so may damage the terminal block.

NG

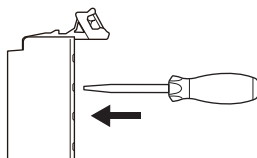

OK

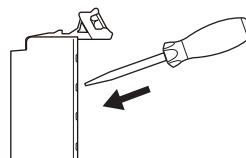

- When you insert a flat-blade screwdriver into a release hole on a screwless clamping terminal block, press it down with a force of 30N or less. Applying excessive force may damage the terminal block.
- Do not incline or twist the flat-blade screwdriver while it is in a release hole on a screwless clamping terminal block. Doing so may damage the terminal block.

NG

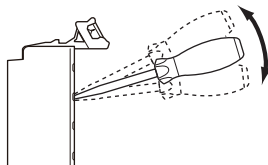

NG

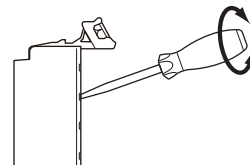

- Make sure that all wiring is correct.
- Do not bend the cable forcibly. Doing so may break the cables.

● Securing Wires

It is necessary to secure wires to the screwless clamping terminal block depending on the wire types that are used or the current flows on the wires.

The following table gives the necessity for securing wires.

Terminals		Wire type				
Classifica- tion	Current ca- pacity	Ferrule	Twisted wires		Solid wires	
			Plated	Unplated	Plated	Unplated
All terminals except ground termi- nals	2 A max.	No	No	No	No	No
	Greater than 2 A and 4 A or less			Yes	Not possible	Yes
			Greater than 4 A		Not possible	No
Ground termi- nals	---	No	No	No	No	No

Use the following procedure to secure the wires.

1 Prepare a cable tie.

A cable tie can be used with a width of 4 mm or less and a thickness of 1.5 mm or less. Select a cable tie correctly for the operating environment.

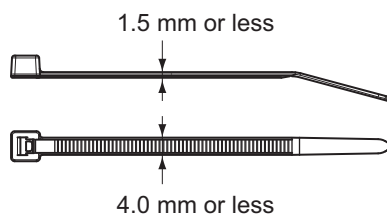

2 Pass a cable tie through the hole for securing wires on the bottom of the screwless clamping terminal block.

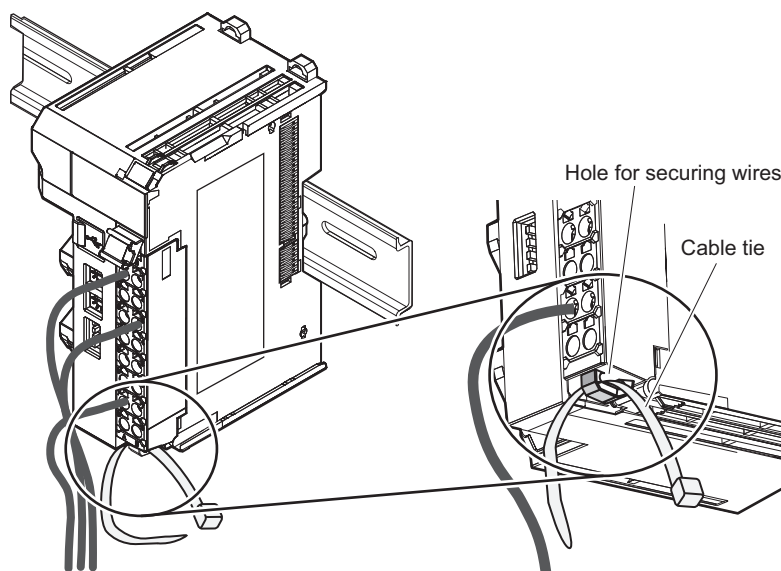

- 3** Bundle the wires with a cable tie and secure them to the screwless clamping terminal block.

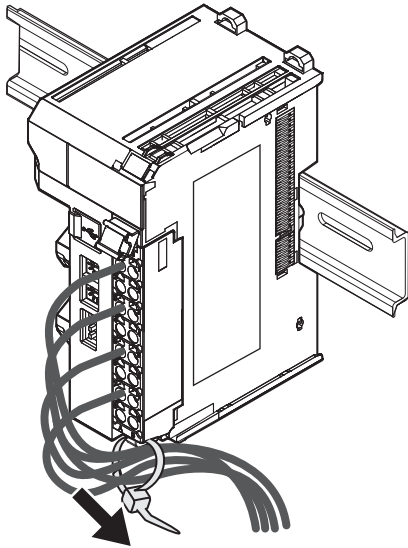

Secure wires within the range of 30 mm from the screwless clamping terminal block.

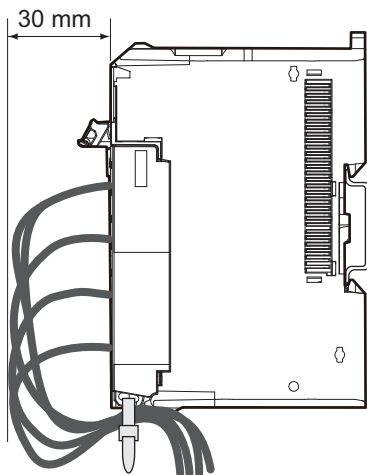

● Removing Wires

Use the following procedure to remove the wires from the terminal block. The removal method is the same for ferrules, twisted wires, and solid wires.

If wires are secured firmly to the terminal block, release them first.

- 1** Press the flat-blade screwdriver diagonally into the release hole. The optimal angle for insertion is between 10° to 15°. If the screwdriver is inserted correctly, you should feel resistance from the spring inside the release hole.

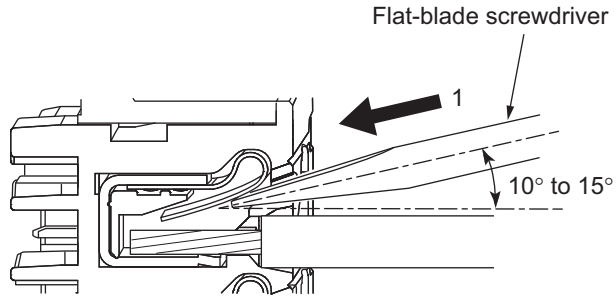

- 2** Insert the flat-blade screwdriver into the release hole and remove the wire from the terminal hole.

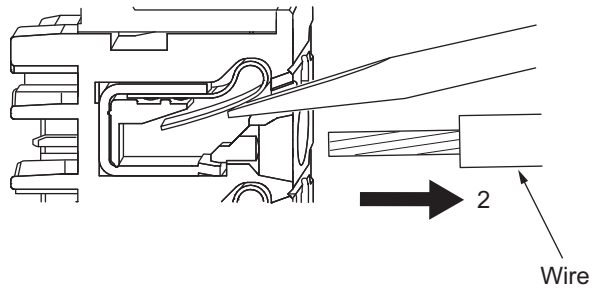

- 3** Remove the flat-blade screwdriver from the release hole.

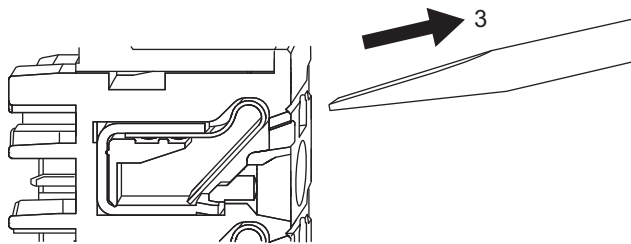



Precautions for Safe Use

- Do not press the flat-blade screwdriver straight into the release holes on a screwless clamping terminal block. Doing so may damage the terminal block.

NG

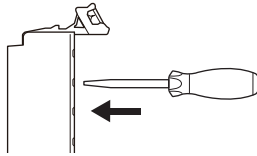

OK

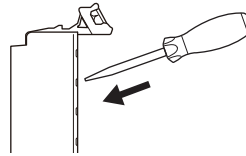

- When you insert a flat-blade screwdriver into a release hole on a screwless clamping terminal block, press it down with a force of 30N or less. Applying excessive force may damage the terminal block.
- Do not incline or twist the flat-blade screwdriver while it is in a release hole on a screwless clamping terminal block. Doing so may damage the terminal block.

NG

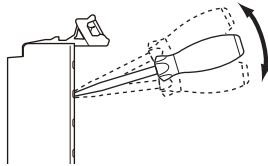

NG

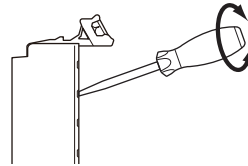

- Make sure that all wiring is correct.
- Do not bend the cable forcibly. Doing so may break the cables.

Removing a Terminal Block

- 1 Press the lock lever on the terminal block and pull out the top of the terminal block to remove it.

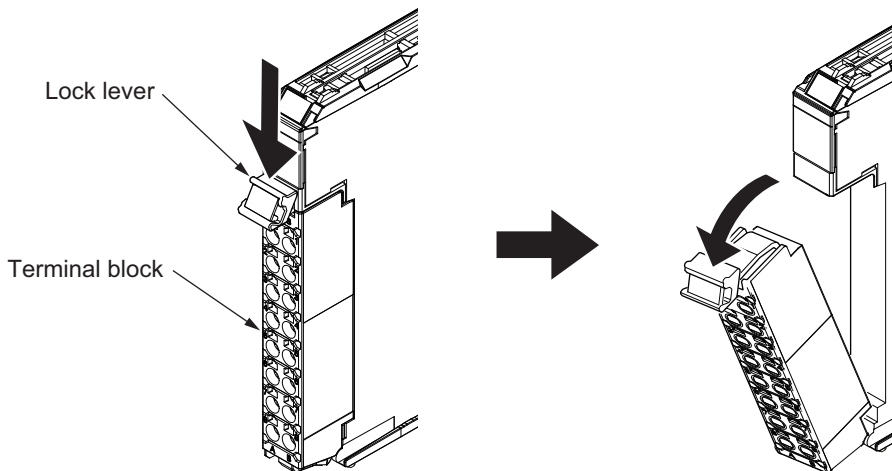

Attaching a Terminal Block

- 1 Mount the terminal block hook that is applicable to each Unit model on the guide at the bottom of the NX Unit, lift up the terminal block, and press in on the top of the terminal block until you hear it engage.
The terminal block will click into place on the Unit. After you mount the terminal block, make sure that it is locked to the Unit.

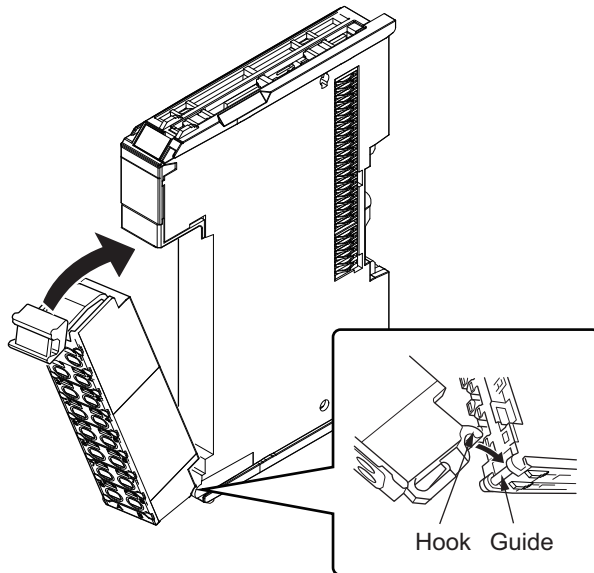

Refer to 3-3 *Terminal Blocks* on page 3-6 for the applicable terminal blocks.

4-3-2 Preventing Incorrect Attachment of Terminal Blocks

In order to prevent unintentionally installing the wrong terminal block, you can limit the combination of a Unit and a terminal block.

Insert three Coding Pins (NX-AUX02) into three of the six incorrect attachment prevention holes on the Unit and on the terminal block. Insert these pins into positions so that they do not interfere with each other when the Unit and terminal block are connected to each other.

You can use these pins to create a combination in which the wrong terminal block cannot be attached because the pin patterns do not match.

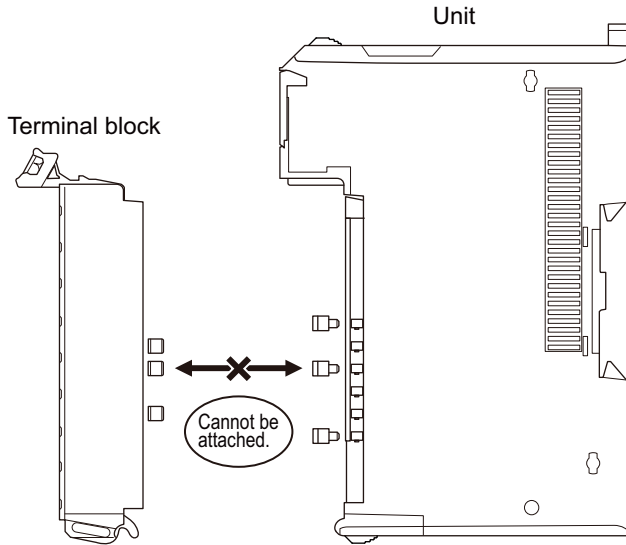

Types of Coding Pins

There are two types of Coding Pins, both with their own unique shape: one for terminal blocks and one for Units.

Three pins come with each runner.

For terminal block

For Unit

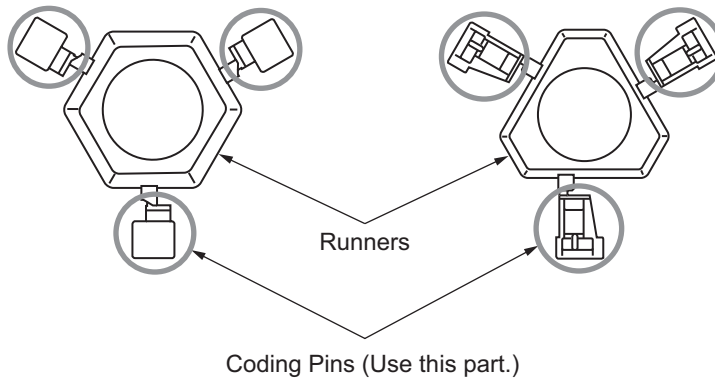

Use the following Coding Pins.

Name	Model	Specification
Coding Pin	NX-AUX02	For 10 Units (Terminal block: 30 pins, Unit: 30 pins)

Insertion Locations and Patterns of Coding Pins

Insert three Coding Pins each on the terminal block and on the Unit at the positions designated by the numbers 1 through 6 in the figure below.

As shown in the following table, there are 20 unique pin patterns that you can use.

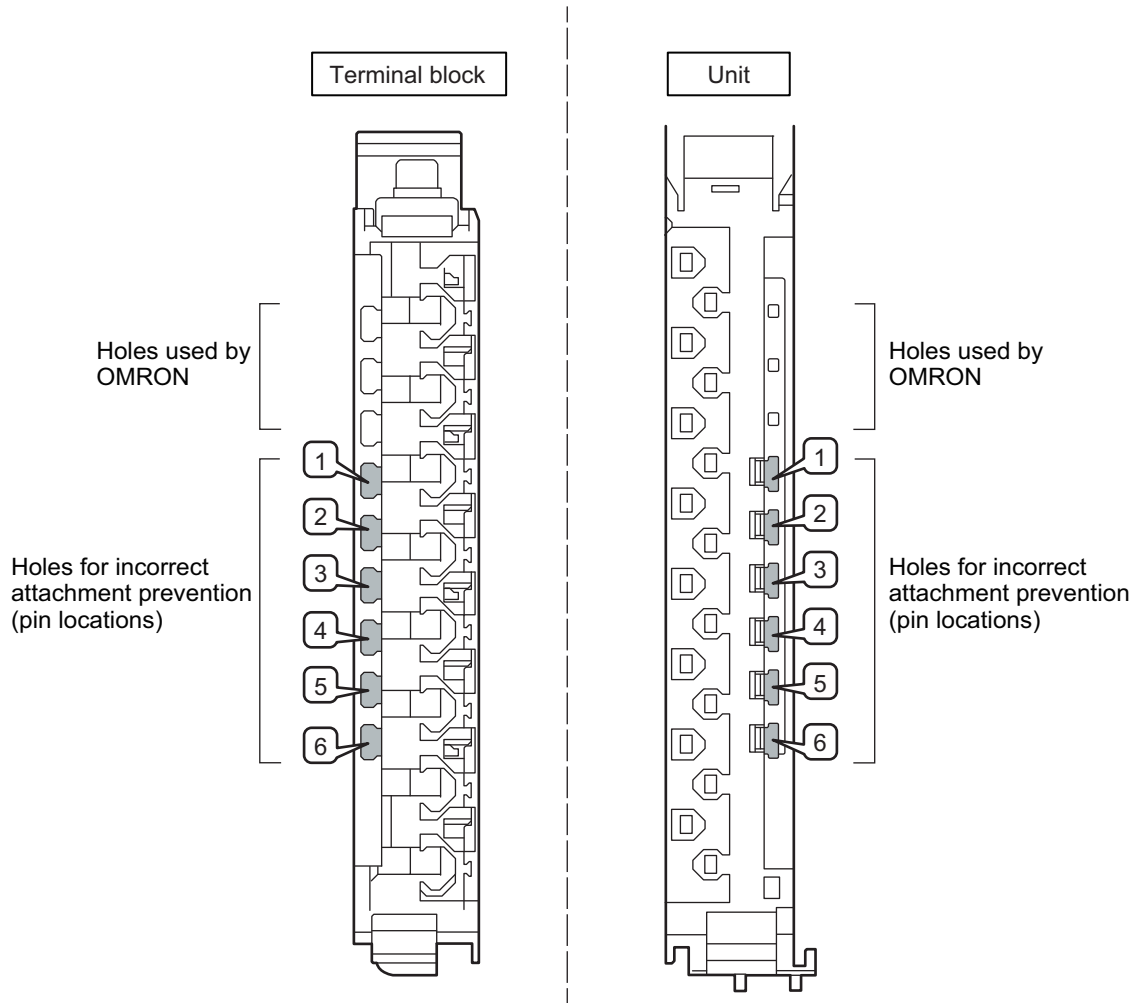

○: Pin inserted

Pattern	Pin locations for terminal block						Pin locations for Unit					
	1	2	3	4	5	6	1	2	3	4	5	6
No.1	○	○	○							○	○	○
No.2	○	○		○					○		○	○
No.3	○	○			○				○	○		○
No.4	○	○				○			○	○	○	
No.5	○		○	○				○			○	○
No.6	○		○		○			○		○		○
No.7	○		○			○		○		○	○	
No.8	○			○	○			○	○			○
No.9	○			○		○		○	○		○	
No.10	○				○	○		○	○	○		
No.11		○	○	○			○				○	○
No.12		○	○		○		○			○		○
No.13		○	○			○	○			○	○	
No.14		○		○	○		○		○			○
No.15		○		○		○	○		○		○	
No.16		○			○	○	○		○	○		
No.17			○	○	○		○	○				○
No.18			○	○		○	○	○			○	
No.19			○		○	○	○	○		○		
No.20			○	○	○		○	○	○			

Two sets of NX-AUX02 Pins are required to make the maximum of 20 pin patterns. (One set for 10 Units.)



Precautions for Correct Use

- The holes not designated by the numbers 1 through 6 in the above figure are used by OMRON. If you insert any Coding Pins into the holes reserved for use by OMRON, you will not be able to mount the terminal block to the Unit.
- Do not use Coding Pins that have been attached and removed.

Inserting the Coding Pins

- 1** Hold the pins by the runner and insert a pin into one of the incorrect attachment prevention holes on the terminal block or on the Unit.

Terminal block

Unit

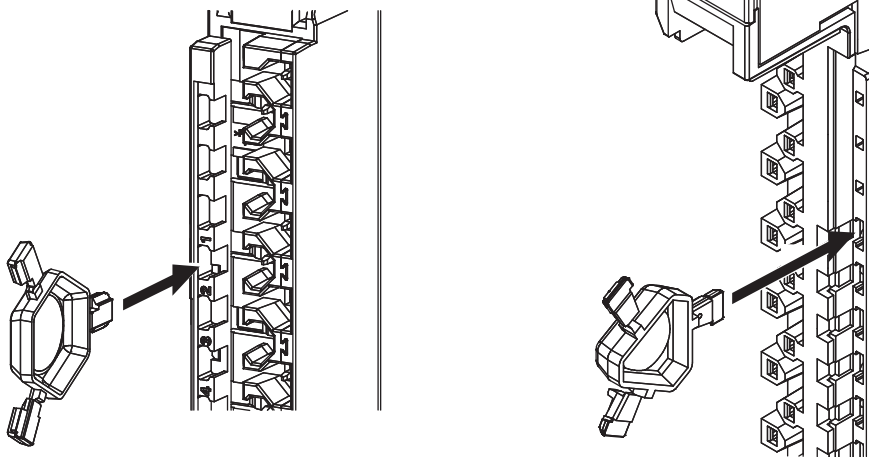

- 2** Rotate the runner to break off the Coding Pin.

Terminal block

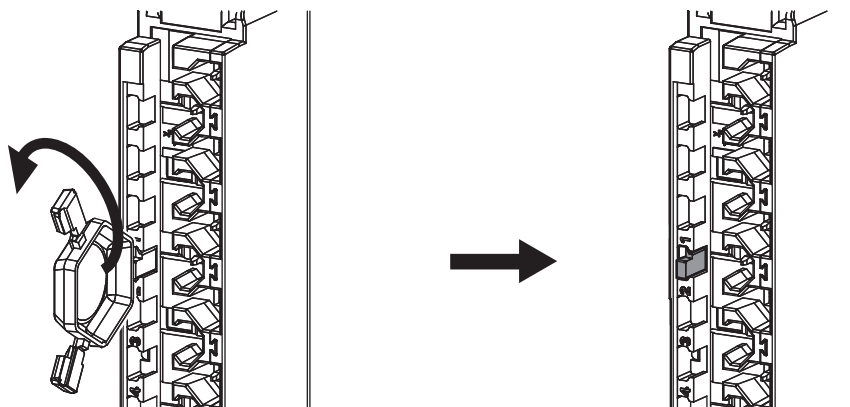

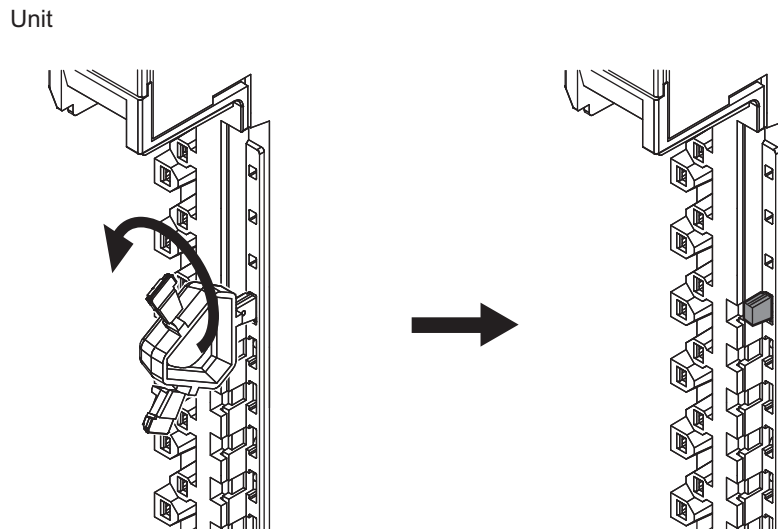

4-3-3 Checking the Wiring

Check the wiring by reading input data or writing output data from Slave Terminals using the Watch Tab Page of the Support Software.

For Input Units, you can input the signals from external devices that are connected to the target Units and monitor the results.

For Output Units, you can execute the outputs of the target Units and check the operation of the connected external devices.

For details on monitoring and I/O output operations using the Support Software, refer to the operation manual for the Support Software that you are using.



Additional Information

- In the Sysmac Studio, you can check the wiring from the I/O Map or Watch Tab Page. If you use the I/O Map, you can also monitor and perform forced refreshing even if the variables are not defined or the algorithms are not created. Therefore, you can easily check the wiring. Refer to the *Sysmac Studio Version 1 Operation Manual (Cat. No. W504)* for details on monitoring and forced refreshing operations.
- Some Communications Coupler Units support I/O checking that allows you to check wiring with only the Slave Terminal. Refer to the user's manual of the Communications Coupler Unit for detailed information on the support and functionality of I/O checking for your Communications Coupler Unit.

4-4 Wiring External Devices

This section provides information on wiring the High-speed Analog Input Units to external devices.

4-4-1 Terminal Block Arrangement

The terminal block arrangement of the High-speed Analog Input Units is shown below.

A1	B1C1		D1
IN1	NC	SHT1+	Input1+
IOV1	IOG1	SHT1-	Input1-
IN2	NC	SHT2+	Input2+
IOV2	IOG2	SHT2-	Input2-
IN3	NC	SHT3+	Input3+
IOV3	IOG3	SHT3-	Input3-
IN4	NC	SHT4+	Input4+
IOV4	IOG4	SHT4-	Input4-

A8 B8C8 D8

Pin No.	Symbol	I/O	Name
A1	IN1	I	Trigger input 1
A2	IOV1	---	I/O power supply +
A3	IN2	I	Trigger input 2
A4	IOV2	---	I/O power supply +
A5	IN3	I	Trigger input 3
A6	IOV3	---	I/O power supply +
A7	IN4	I	Trigger input 4
A8	IOV4	---	I/O power supply +

Pin No.	Symbol	I/O	Name
B1	NC	---	Not used
B2	IOG1	---	I/O power supply -
B3	NC	---	Not used
B4	IOG2	---	I/O power supply -
B5	NC	---	Not used
B6	IOG3	---	I/O power supply -
B7	NC	---	Not used
B8	IOG4	---	I/O power supply -

Pin No.	Symbol	I/O	Name
C1	SHT1+	O	Current input selection 1+
C2	SHT1-	I	Current input selection 1-
C3	SHT2+	O	Current input selection 2+
C4	SHT2-	I	Current input selection 2-
C5	SHT3+	O	Current input selection 3+
C6	SHT3-	I	Current input selection 3-
C7	SHT4+	O	Current input selection 4+
C8	SHT4-	I	Current input selection 4-

Pin No.	Symbol	I/O	Name
D1	Input1+	I	Analog input 1+
D2	Input1-	I	Analog input 1-
D3	Input2+	I	Analog input 2+
D4	Input2-	I	Analog input 2-
D5	Input3+	I	Analog input 3+
D6	Input3-	I	Analog input 3-
D7	Input4+	I	Analog input 4+
D8	Input4-	I	Analog input 4-

4-4-2 Wiring Examples

Wiring examples for the High-speed Analog Input Units are shown below.

Wiring Examples for the NX-HAD401

● Wiring Example 1 (Analog input range: Voltage)

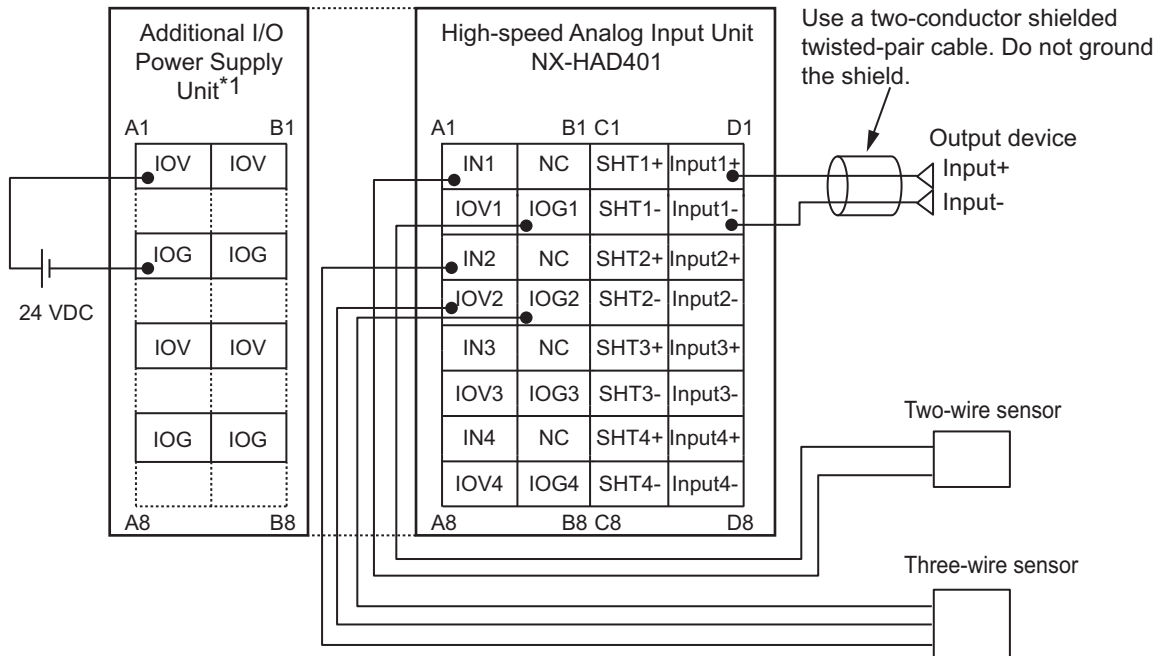

*1. Besides the Additional I/O Power Supply Unit, some other Units can supply I/O power to the NX bus. For example, you can use a Connected Communications Coupler Unit. If you use this Unit to supply I/O power to the High-speed Analog Input Units, the Additional I/O Power Supply Unit is unnecessary. The Additional I/O Power Supply Unit is also unnecessary if you do not use the trigger inputs of the High-speed Analog Input Units.

● Wiring Example 2 (Analog input range: Current)

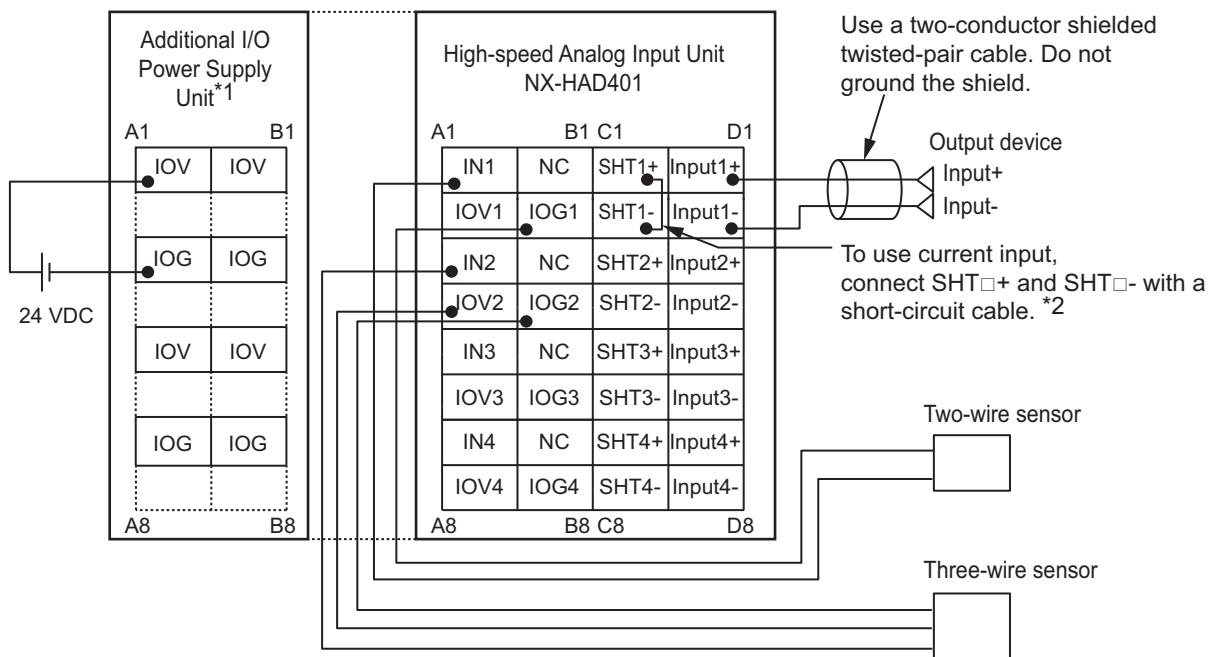

*1. Besides the Additional I/O Power Supply Unit, some other Units can supply I/O power to the NX bus. For example, you can use a Connected Communications Coupler Unit. If you use this Unit to supply I/O power to the High-speed Analog Input Units, the Additional I/O Power Supply Unit is unnecessary. The Additional

I/O Power Supply Unit is also unnecessary if you do not use the trigger inputs of the High-speed Analog Input Units.

*2. Short-circuit cables are not included in the product.



Precautions for Correct Use

The cable length of a short-circuit cable used for current input must be 4 cm or less and allow for wiring to the screwless clamping terminal block. Be sure to use cables and ferrules that are applicable to the screwless clamping terminal block. If the cable is too long, the analog input values may not be accurate.

Wiring Examples for the NX-HAD402

● **Wiring Example 1 (Analog input range: Voltage)**

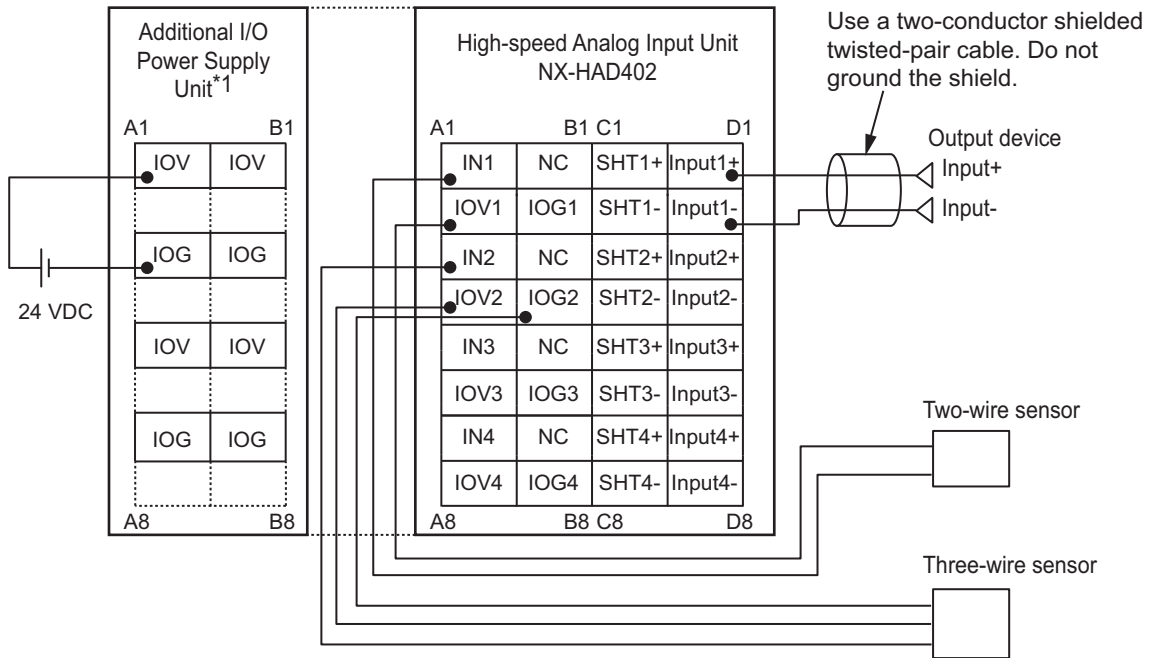

*1. Besides the Additional I/O Power Supply Unit, some other Units can supply I/O power to the NX bus. For example, you can use a Connected Communications Coupler Unit. If you use this Unit to supply I/O power to the High-speed Analog Input Units, the Additional I/O Power Supply Unit is unnecessary. The Additional I/O Power Supply Unit is also unnecessary if you do not use the trigger inputs of the High-speed Analog Input Units.

● Wiring Example 2 (Analog input range: Current)

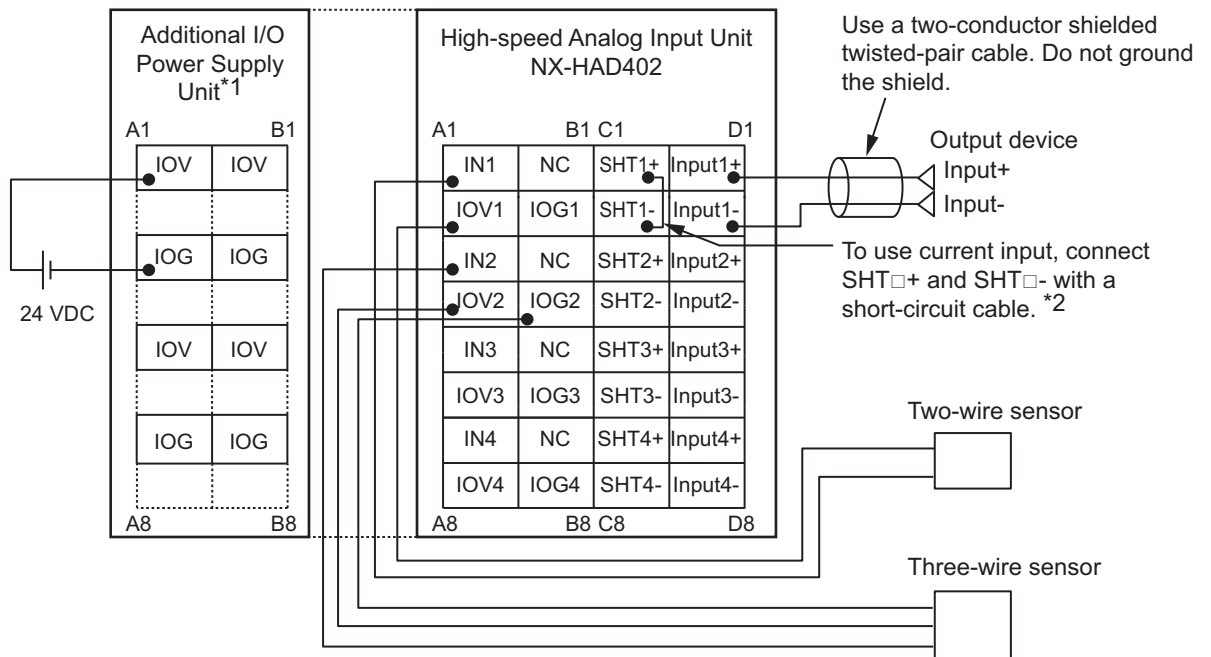

- *1. Besides the Additional I/O Power Supply Unit, some other Units can supply I/O power to the NX bus. For example, you can use a Connected Communications Coupler Unit. If you use this Unit to supply I/O power to the High-speed Analog Input Units, the Additional I/O Power Supply Unit is unnecessary. The Additional I/O Power Supply Unit is also unnecessary if you do not use the trigger inputs of the High-speed Analog Input Units.
- *2. Short-circuit cables are not included in the product.



Precautions for Correct Use

The cable length of a short-circuit cable used for current input must be 4 cm or less and allow for wiring to the screwless clamping terminal block. Be sure to use cables and ferrules that are applicable to the screwless clamping terminal block. If the cable is too long, the analog input values may not be accurate.

4-4-3 Precautions for Wiring

This section describes precautions that should be taken when you wire the High-speed Analog Input Units.

- Precautions when the Unit is easily affected by noise
- Precautions when connecting a two-wire DC sensor

When the Unit is Easily Affected by Noise

If the Unit is easily affected by noise, use the following shielded wires and ground the end of the shield on the High-speed Analog Input Unit side:

- Analog input
Two-conductor shielded twisted-pair cable
- Trigger input

For connection to a two-wire sensor: Two-conductor shielded twisted-pair cable

For connection to a three-wire sensor: Three-conductor shielded twisted-pair cable

However, do not connect the end of the shield anywhere on the output device. If you ground the shield on both the High-speed Analog Input Unit side and the output device side, the Unit becomes susceptible to noise induced due to ground loops.

When you ground the end of the shield, you can use the NX-TBX01 Shield Connection Unit to ground more than one shield.

A wiring example is shown below.

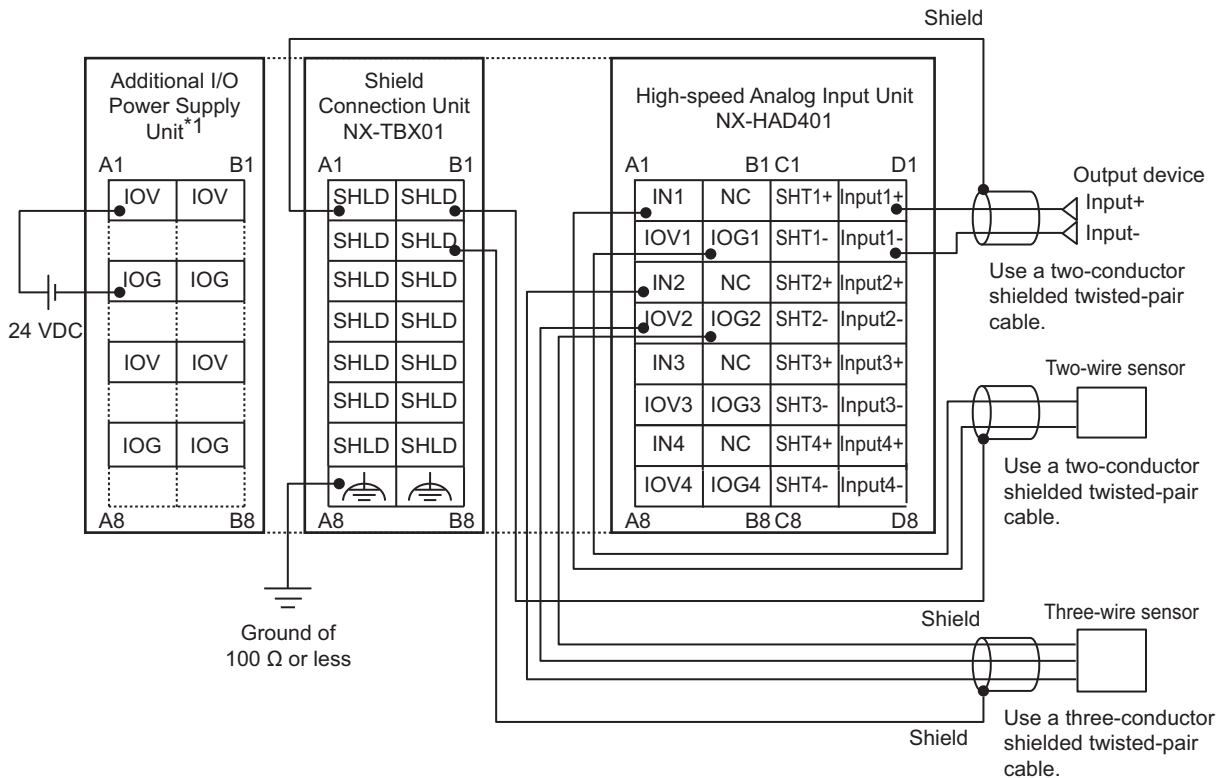

Connect the shield of cable to the SHLD terminal on the Shield Connection Unit.
And ground the functional ground terminal on the Shield Connection Unit to 100 Ω or less.

*1. Besides the Additional I/O Power Supply Unit, some other Units can supply I/O power to the NX bus. For example, you can use a Connected Communications Coupler Unit. If you use this Unit to supply I/O power to the High-speed Analog Input Units, the Additional I/O Power Supply Unit is unnecessary. The Additional I/O Power Supply Unit is also unnecessary if you do not use the trigger inputs of the High-speed Analog Input Units.



Precautions for Correct Use

To ensure this NX Unit is kept in the best operating condition, observe the following points when wiring to avoid the effects of the noise.

- Use a shield wire (2 conductors, twisted wire) or a shield wire (3 conductors) as the analog input connection line for each input.
- Wire the input connection lines and power lines (e.g., AC power supply lines or power lines) separately. Do not place such lines in the same duct.
- Insert a noise filter into the power supply input section if noise comes from power supply lines when using the same power supply to power an electrical welder or an electric discharge machine, or there is a high-frequency source nearby.

Precautions When Connecting a Two-wire DC Sensor

When a two-wire sensor is used with the trigger inputs of the High-speed Analog Input Units, check that the following conditions are met. Failure to meet these conditions may result in operating errors.

● Relation between ON Voltage at Trigger Inputs and Sensor Residual Voltage

The trigger inputs of the High-speed Analog Input Units can detect sensor output ON only when the following conditions are satisfied:

$$V_{ON} \leq V_{CC} - V_R$$

The voltages related to the conditions for NPN type sensors are shown in the figure below.

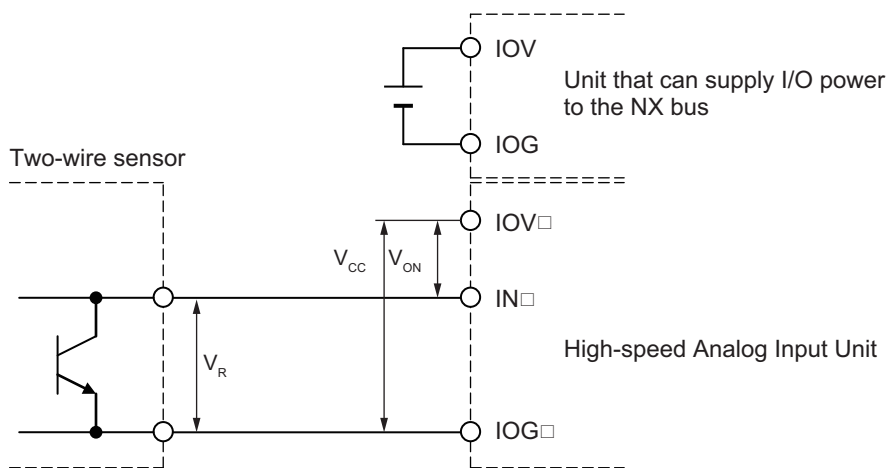

The voltages related to the conditions for PNP type sensors are shown in the figure below.

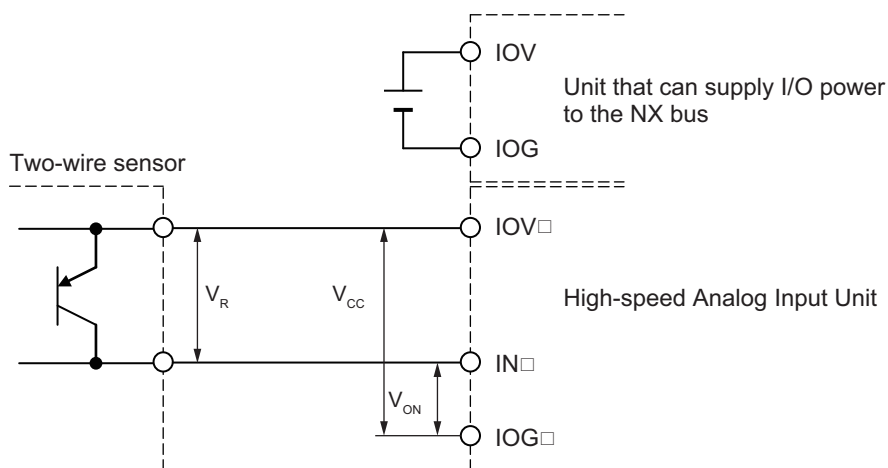

V_{CC} : Power supply voltage

V_R : Sensor's output residual voltage

V_{ON} : ON voltage at trigger input of the High-speed Analog Input Unit

● Relation between Input Current at Trigger Input Terminals and Sensor Control Output (Load Current)

The trigger inputs of the High-speed Analog Input Units can detect sensor output ON only when the following conditions are satisfied:

$$I_{OUT}(\min) \leq I_{in} \leq I_{OUT}(\max)$$

$I_{OUT}(\min)$: Minimum value of load current

$I_{OUT}(\max)$: Maximum value of load current

Use the following equation to calculate the input current:

$$I_{in} = I_{ON}$$

Note At the trigger input terminals of the High-speed Analog Input Units, the input current does not increase linearly for the input voltage. If you gradually raise the input voltage and once the input current reaches I_{ON} , the input current does not increase any further, and remains roughly constant even when the input voltage is raised.

When I_{in} is smaller than $I_{OUT}(\min)$, connect a bleeder resistor R . The bleeder resistor constant can be calculated as follows: Select an appropriate bleeder resistor R so that both equations can be satisfied.

$$R \leq (V_{CC} - V_R) / (I_{OUT}(\min.) - I_{ON})$$

$$\text{Rated power } W \text{ of bleeder resistor} \geq (V_{CC} - V_R)^2 / R \times 4 \text{ [allowable margin]}$$

The voltages and currents related to the conditions for NPN type sensors are shown in the figure below.

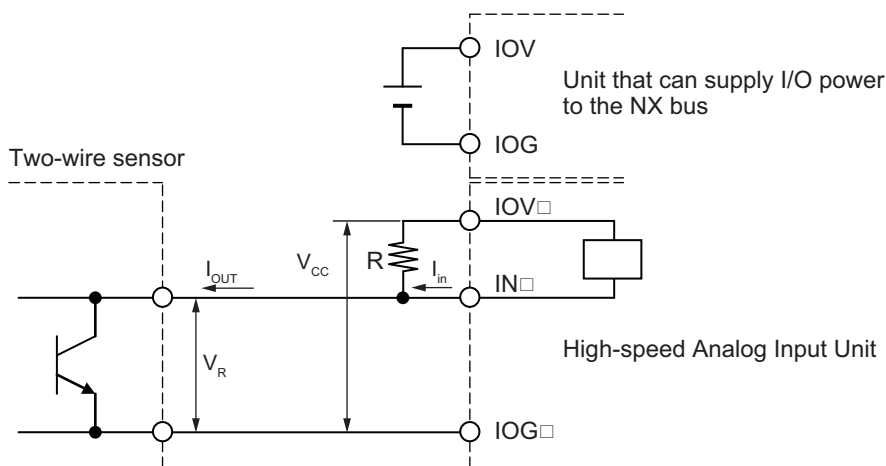

The voltages and currents related to the conditions for PNP type sensors are shown in the figure below.

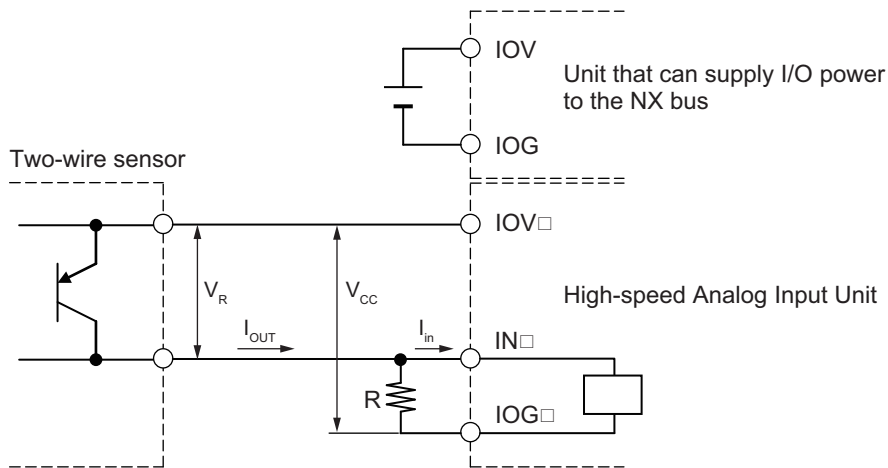

V_{CC} : Power supply voltage

V_R : Sensor's output residual voltage

I_{OUT} : Sensor control output (load current)

I_{ON} : Input current at trigger input terminal of the High-speed Analog Input Unit (Input current when the rated voltage is applied)

R: Bleeder resistor

● Relation between OFF Current at Trigger Inputs and Sensor Leakage Current

The trigger inputs of the High-speed Analog Input Units can detect sensor output OFF only when the following conditions are satisfied:

$$I_{OFF} \leq I_{leak}$$

When I_{leak} is greater than I_{OFF} , connect a bleeder resistor R.

Use the following equation to calculate the bleeder resistance constant.

$$R \leq (V_{OFF}/I_{OFF}) \times V_{OFF}/(I_{leak} \times (V_{OFF}/I_{OFF}) - V_{OFF})$$

Use the following equation to calculate the rated power of a bleeder resistor.

$$\text{Rated power } W \text{ of bleeder resistor} \geq (V_{CC} - V_R)^2/R \times 4 \text{ [allowable margin]}$$

The voltages and currents related to the conditions for NPN type sensors are shown in the figure below.

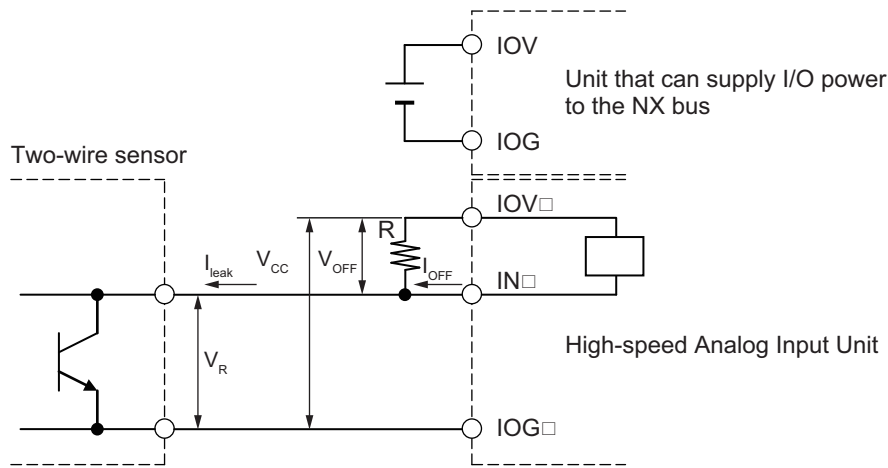

The voltages and currents related to the conditions for PNP type sensors are shown in the figure below.

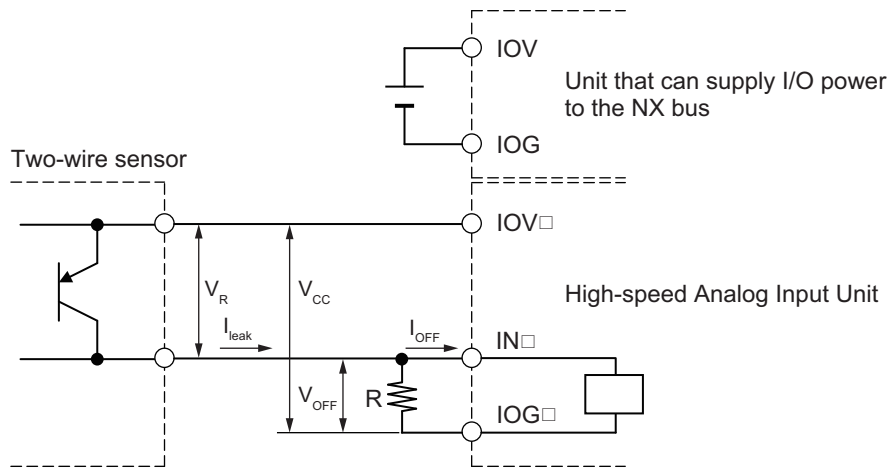

V_{CC} : Power supply voltage

V_R : Sensor's output residual voltage

V_{OFF} : OFF voltage at trigger input of the High-speed Analog Input Unit

I_{leak} : Sensor leakage current

R: Bleeder resistor

I_{OFF} : OFF current at trigger input of the High-speed Analog Input Unit

● Precautions on Sensor Inrush Current

An incorrect input may occur due to sensor inrush current if a sensor is turned ON after the High-speed Analog Input Unit has started up to the point where inputs are possible.

Determine the time required for sensor operation to stabilize after the sensor is turned ON, and take appropriate measures, such as inserting an ON delay into the user program after turning ON the sensor.

A programming example is shown below.

The sensor's power supply voltage is used as the input bit to *Sensor_power*.

A 100-ms timer delay (the time required for an OMRON Proximity Sensor to stabilize) is created in the user program.

After the timer changes to TRUE, input bit X causes the output *Output* to change to TRUE after the input of the sensor changes to TRUE.

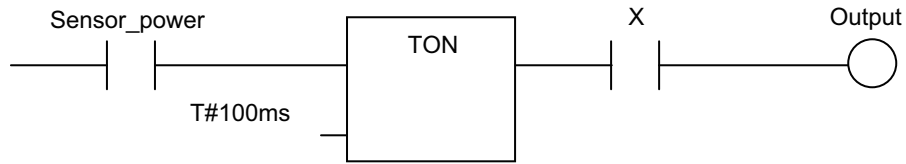

5

I/O Refreshing

This section describes the types and functions of I/O refreshing for the NX Units.

5-1	I/O Refreshing	5-2
5-1-1	I/O Refreshing from CPU Units to NX Units	5-2
5-1-2	I/O Refreshing from CPU Units or Industrial PCs to Slave Terminal	5-3
5-1-3	Calculating the I/O Response Time of NX Units.....	5-4
5-2	I/O Refreshing Methods	5-6
5-2-1	Types of I/O Refreshing Methods	5-6
5-2-2	Setting the I/O Refreshing Methods	5-7
5-2-3	Restrictions in Refresh Cycles	5-8
5-2-4	I/O Refreshing Operation	5-9

5-1 I/O Refreshing

This section describes I/O refreshing for NX Units.

5-1-1 I/O Refreshing from CPU Units to NX Units

An NX-series CPU Unit cyclically performs I/O refreshing with the NX Units.

The following period and two cycles affect operation of the I/O refreshing between the CPU Unit and the NX Units.

- a. Primary period in CPU Unit
- b. Refresh cycle of the NX bus
- c. Refresh cycle of each NX Unit

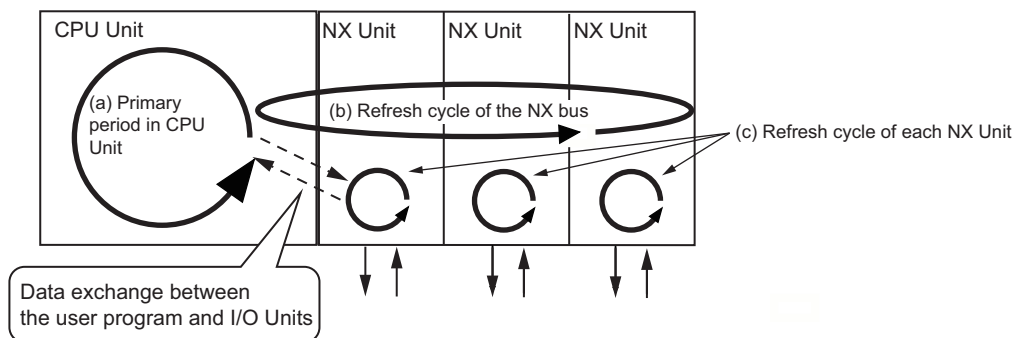

The following operation occurs.

- The refresh cycle of the NX bus in item (b) is automatically synchronized with the primary period of the CPU Unit in item (a).
- The refresh cycle of each NX Unit in item (c) depends on the I/O refreshing method which is given below.

Refer to the *NJ/NX-series CPU Unit Software User's Manual (Cat. No. W501)* for detailed information on I/O refreshing between the CPU Unit and the NX Units.

Refer to *5-1-3 Calculating the I/O Response Time of NX Units* on page 5-4 for the I/O response time of NX Units in a CPU Rack.

5-1-2 I/O Refreshing from CPU Units or Industrial PCs to Slave Terminal

The CPU Unit or the Industrial PC cyclically performs I/O refreshing with the Slave Terminal through the Communications Master Unit and the Communications Coupler Unit.

The following four cycles affect operation of the I/O refreshing between the NX Unit on a Slave Terminal and the CPU Unit or Industrial PC.

- Cycle time of the CPU Unit or Industrial PC
- Communications cycle of the host network
- Refresh cycle of the NX bus
- Refresh cycle of each NX Unit

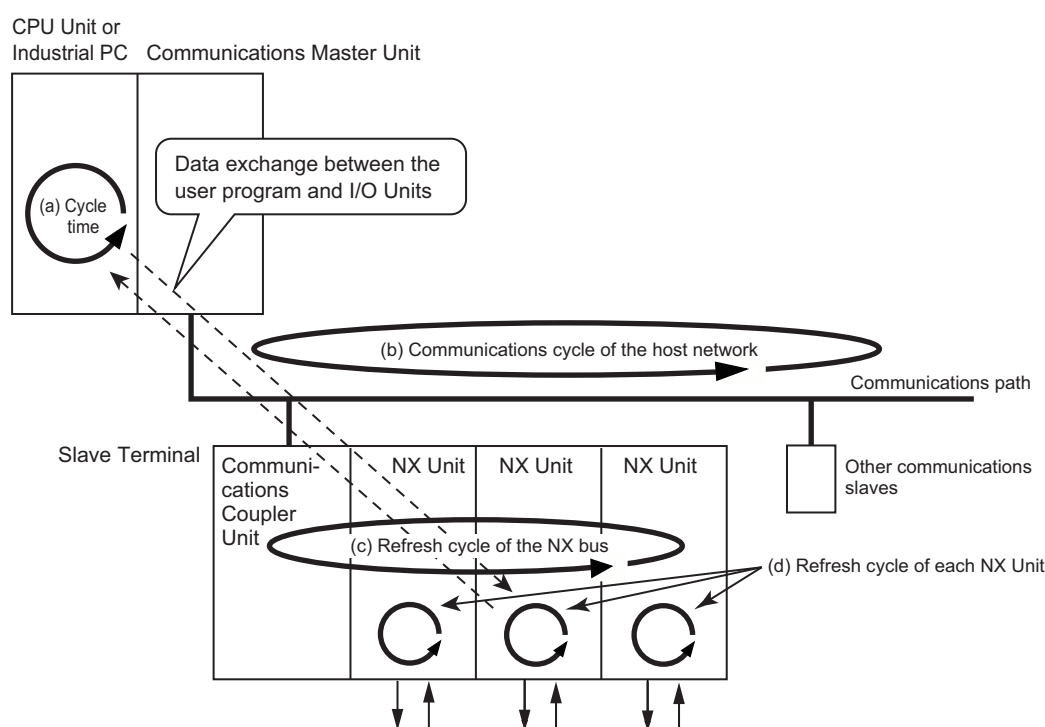

The cycle time of the CPU Unit or Industrial PC and communications cycle of the host network and the I/O refresh cycle of the NX bus are determined by the CPU Unit or Industrial PC types and the communications types.

The following explains operations when the built-in EtherCAT port on the NJ/NX-series CPU Unit or NY-series Industrial PC is used for communications with an EtherCAT Slave Terminal, with symbols in the figure.

Refer to the user's manual for the connected Communications Coupler Unit for details on the operation of I/O refreshing on Slave Terminals other than EtherCAT Slave Terminals.

Refer to the *NX-series EtherCAT Coupler Units User's Manual (Cat. No. W519)* for detailed information on I/O refreshing between the built-in EtherCAT port and EtherCAT Slave Terminals.

In addition, refer to 5-1-3 *Calculating the I/O Response Time of NX Units* on page 5-4 for the I/O response time of NX Units on Slave Terminals.

Operation of I/O Refreshing with NX-series CPU Units

The following shows the operation of I/O refreshing when the built-in EtherCAT port on the NX-series CPU Unit is used for communications with an EtherCAT Slave Terminal.

- The process data communications cycle in item (b) and the refresh cycle of the NX bus in item (c) are automatically synchronized with the primary period or the task period of the priority-5 periodic task of the CPU Unit in item (a). *1
- The refresh cycle of each NX Unit in item (d) depends on the I/O refreshing method which is given below.

*1. This applies when the distributed clock is enabled in the EtherCAT Coupler Unit.

The priority-5 periodic tasks must be supported by the connected CPU Unit model. Refer to descriptions of designing tasks in the *NJ/NX-series CPU Unit Software User's Manual (Cat. No. W501)* for information on the periodic tasks supported by each NX-series CPU Unit model.

Operation of I/O Refreshing with NJ-series CPU Units or NY-series Industrial PCs

The following shows the operation of I/O refreshing when the built-in EtherCAT port on the NJ-series CPU Unit or NY-series Industrial PC is used for communications with an EtherCAT Slave Terminal.

- The process data communications cycle in item (b) and the refresh cycle of the NX bus in item (c) are automatically synchronized with the primary period of the CPU Unit or Industrial PC in item (a). *1
- The refresh cycle of each NX Unit in item (d) depends on the I/O refreshing method which is given below.

*1. This applies when the distributed clock is enabled in the EtherCAT Coupler Unit.

5-1-3 Calculating the I/O Response Time of NX Units

Depending on where the NX Unit is connected, refer to the following manuals to calculate the I/O response times of an NX unit.

Connected to a CPU Unit

Manual for reference	Description
Software user's manual for the connected CPU Unit	The method for calculating the I/O response times of NX Units in the CPU Rack with a CPU Unit is described.
NX-series Data Reference Manual	The NX Unit parameter values used for calculating the I/O response times of NX Units are described.

Connected to a Communications Coupler Unit

Manual for reference	Description
User's manual for the connected Communications Coupler Unit	The method for calculating the I/O response times of NX Units on Slave Terminals is described.

Manual for reference	Description
NX-series Data Reference Manual	The NX Unit parameter values used for calculating the I/O response times of NX Units are described.

5-2 I/O Refreshing Methods

This section describes I/O refreshing methods for the NX Units.

5-2-1 Types of I/O Refreshing Methods

The I/O refreshing methods that you can use between the CPU Unit or Communications Coupler Unit and the NX Units are determined by the CPU Unit or Communications Coupler Unit that is used. For the High-speed Analog Input Units, synchronous I/O refreshing as described below is always used.

I/O refreshing method name	Outline of operation
Synchronous I/O refreshing	With this I/O refreshing method, the timing to read inputs or to refresh outputs is synchronized on a fixed interval between more than one NX Unit connected to a CPU Unit.

5-2-2 Setting the I/O Refreshing Methods

Setting Methods between the CPU Unit and the NX Units

How to set an I/O refreshing method between the CPU Unit and the NX Units is determined by the connected CPU Unit.

Refer to descriptions of I/O refreshing methods in the software user's manual for the connected CPU Unit for information on the setting method for I/O refreshing between the CPU Unit and the NX Units.

An example of the setting operation for the NX-series NX102 CPU Unit is shown below.

For the NX102 CPU Unit, no setting operation is required, and the method is determined according to the following table.

NX Units that support only Free-Run refreshing	NX Units that support only synchronous I/O refreshing	NX Units that support both Free-Run refreshing and synchronous I/O refreshing	NX Units that support Free-Run refreshing, synchronous I/O refreshing, and task period prioritized refreshing	NX Units that support only time stamp refreshing*1
Free-Run refreshing	Synchronous I/O refreshing			Time stamp refreshing

*1. Two types of time stamp refreshing are available: one is input refreshing with input changed time and the other is output refreshing with specified time stamp.

Because the High-speed Analog Input Units support only the synchronous I/O refreshing method, synchronous I/O refreshing is always used.

Setting Methods between the Communications Coupler Unit and the NX Units

How to set an I/O refreshing method between the Communications Coupler Unit and the NX Units is determined by the connected Communications Coupler Unit.

Refer to the user's manual for the connected Communications Coupler Unit for information on how to set an I/O refreshing method between the Communications Coupler Unit and the NX Units.

An example when the EtherCAT Coupler Unit is connected to the built-in EtherCAT port on an NJ/NX-series CPU Unit or NY-series Industrial PC is shown below.

The I/O refreshing method between the EtherCAT Coupler Unit and each NX Unit depends on whether the DC is enabled in the EtherCAT Coupler Unit.

DC enable setting in the EtherCAT Coupler Unit	NX Units that support only synchronous I/O refreshing	NX Units that support only Free-Run refreshing	NX Units that support both Free-Run refreshing and synchronous I/O refreshing	NX Units that support Free-Run refreshing, synchronous I/O refreshing, and task period prioritized refreshing	NX Units that support only time stamp refreshing ^{*1}
Enabled (DC for synchronization) ^{*2}	Synchronous I/O refreshing	Free-Run refreshing	Synchronous I/O refreshing	Synchronous I/O refreshing	Time stamp refreshing
Enabled (DC with priority in cycle time) ^{*2}				Task period prioritized refreshing	
Disabled (Free-Run) ^{*3}	Not available.		Free-Run refreshing	Free-Run refreshing	Operation with time stamp refreshing is not possible. ^{*4}

*1. Two types of time stamp refreshing are available: one is input refreshing with input changed time and the other is output refreshing with specified time stamp.

*2. The EtherCAT Slave Terminal operates in DC Mode.

*3. The EtherCAT Slave Terminal operates in Free-Run Mode.

*4. Refer to the manuals for the specific NX Units for details on the operation when the DC is set to Disabled (FreeRun).

Because the High-speed Analog Input Units support only the synchronous I/O refreshing method, synchronous I/O refreshing is always used.

EtherCAT Coupler Unit is the only Communications Coupler Unit that can be connected to the High-speed Analog Input Units. Other Communications Coupler Units cannot be connected.



Additional Information

The EtherCAT Slave Terminals with DC enabled and EtherCAT slaves that support DC synchronization execute I/O processing based on Sync0, which is shared over the EtherCAT network. However, EtherCAT slaves and NX Units support different specifications and performance for the timing to read inputs and refresh outputs. Accordingly, their timing to read inputs and refresh outputs is not synchronized.

Refer to the manuals for the EtherCAT slaves for information on the timing to read inputs or to refresh outputs in EtherCAT slaves.

5-2-3 Restrictions in Refresh Cycles

The refresh cycle for synchronous I/O refreshing of the High-speed Analog Input Units should be within the following limits.

I/O refreshing method	Refresh cycle
Synchronous I/O refreshing ^{*1}	125 μ s to 32 ms

*1. The refresh cycle depends on the specifications of the EtherCAT master and EtherCAT Coupler Unit. It also depends on the Unit configuration.



Precautions for Correct Use

If you use synchronous I/O refreshing, set the task period of the periodic task as follows.

- A value within the specified refresh cycle range of the High-speed Analog Input Unit
- A value larger than the NX bus refresh cycle that is automatically calculated by the Support Software

Also refer to the user's manual for the connected CPU Unit or EtherCAT Coupler Unit for information on setting the task periods of periodic tasks.

5-2-4 I/O Refreshing Operation

This section describes the operation of synchronous I/O refreshing that the High-speed Analog Input Units support. It also describes the sampling operation of the High-speed Analog Input Units.

The following describes the method of synchronous I/O refreshing.

- The timing to read inputs or to refresh outputs is synchronized on a fixed interval between more than one NX Unit connected to a CPU Unit.
- The timing to read inputs or to refresh outputs is synchronized on a fixed interval between more than one NX Unit on more than one Slave Terminal.

The operation of I/O refreshing in the CPU Unit and that in the Slave Terminal are given below.

CPU Unit Operation

The following describes the operation of synchronous I/O refreshing between an NX-series CPU Unit and the NX Units.

- All NX Units that are connected to the CPU Unit and operate with synchronous input refreshing read their inputs at the same time at a fixed interval based on the synchronization timing. (Refer to (a) in the figure below.)
- The High-speed Analog Input Units perform conversions in order to obtain the input values of the final analog input data sampled, before the timing to read inputs.
The timing of starting the AD conversion in the first sampling is the same for all channels of the High-speed Analog Input Unit. (Refer to (b) in the figure below.)
Similarly, for all channels of the High-speed Analog Input Unit that perform the same number of samplings, the timing of starting the AD conversion in the second and later samplings is the same. (Refer to (c) in the figure below.)
- The CPU Unit reads the analog input values, which are read by the Unit at the timing of reading inputs, at immediate I/O refreshing. (Refer to (d) in the figure below.)
- The interval of I/O refreshing varies with the processing conditions of the CPU Unit. (Refer to (e) in the figure below.) The timing to read inputs will be at a fixed interval. (Refer to (f) and (g) in the figure below.)
- The timing of reading inputs, the synchronization timing, and the maximum NX bus I/O refresh cycle are automatically calculated by the Support Software according to the input refresh cycles of the NX Units on the CPU Unit when a Unit configuration in the CPU Unit is created and set up.

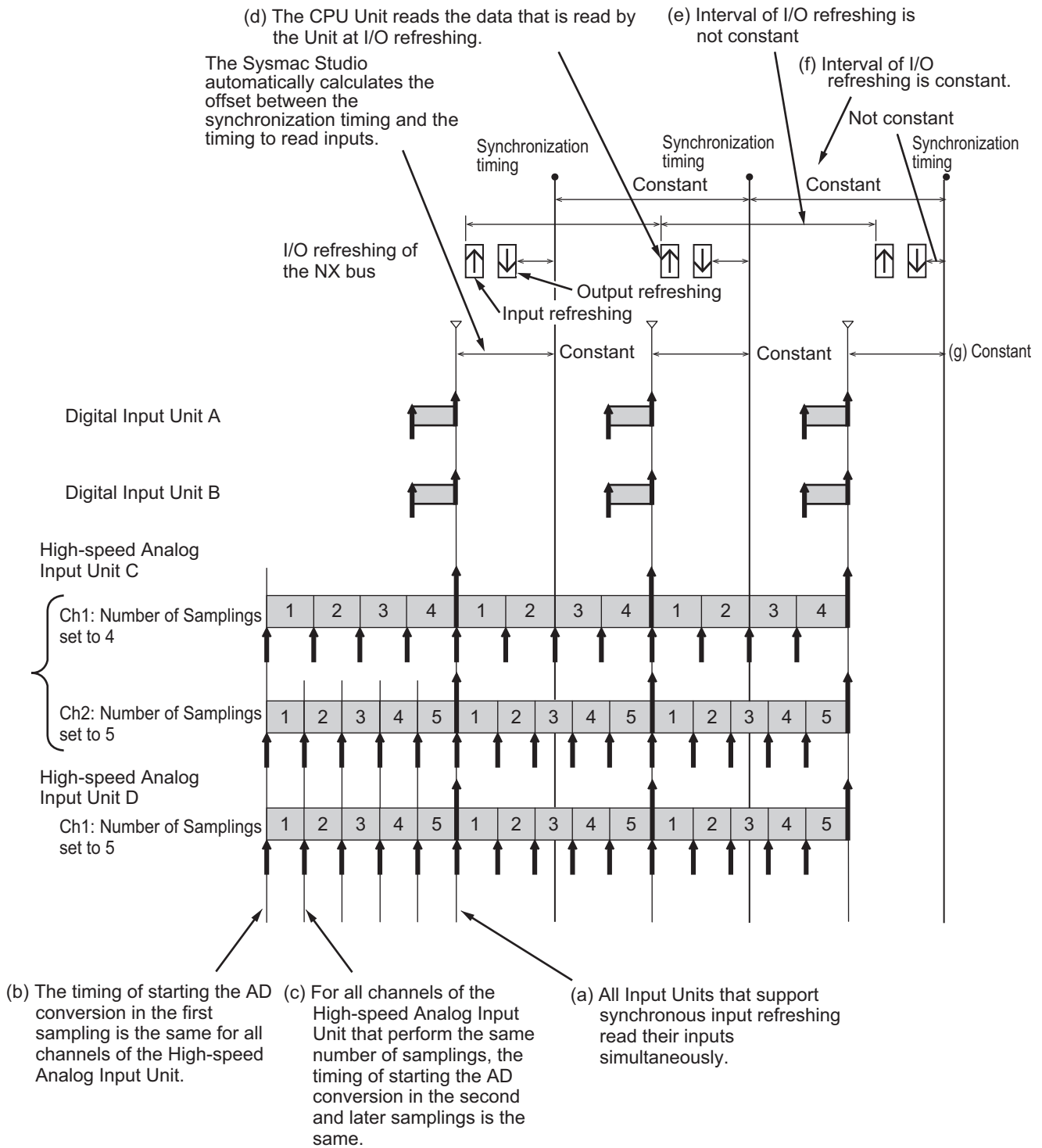

Slave Terminal Operation

The following describes the operation of synchronous I/O refreshing of an EtherCAT Slave Terminal.

- The NX Units that operate with synchronous input refreshing in a Slave Terminal read inputs at a fixed interval based on Sync0. (Refer to (a) in the figure below.)*¹

- The High-speed Analog Input Units perform conversions in order to obtain the input values of the final analog input data sampled, before the timing to read inputs.
The timing of starting the AD conversion in the first sampling is the same for all channels of the High-speed Analog Input Unit. (Refer to (b) in the figure below.)
Similarly, for all channels of the High-speed Analog Input Unit that perform the same number of samplings, the timing of starting the AD conversion in the second and later samplings is the same. (Refer to (c) in the figure below.)
 - The Communications Coupler Unit reads the analog input values, which are read by the Unit at the timing of reading inputs, at immediate I/O refreshing. (Refer to (d) in the figure below.)
 - The interval of I/O refreshing varies with the processing conditions of the Communications Coupler Unit or the host communications master. (Refer to (e) in the figure below.) The timing to read inputs will be at a fixed interval. (Refer to (f) and (g) in the figure below.)
 - The Sync0, the timing to read inputs and the maximum NX bus I/O refresh cycle of the Slave Terminals are automatically calculated by the Sysmac Studio according to the input refresh cycle of the NX Units in the Slave Terminals when the Slave Terminals are configured and set up.
- *1. If multiple Slave Terminals are present on the same EtherCAT network, refer to *NX-series EtherCAT Coupler Units User's Manual (Cat. No. W519)* for the range of available Slave Terminals that operate at the same timing.

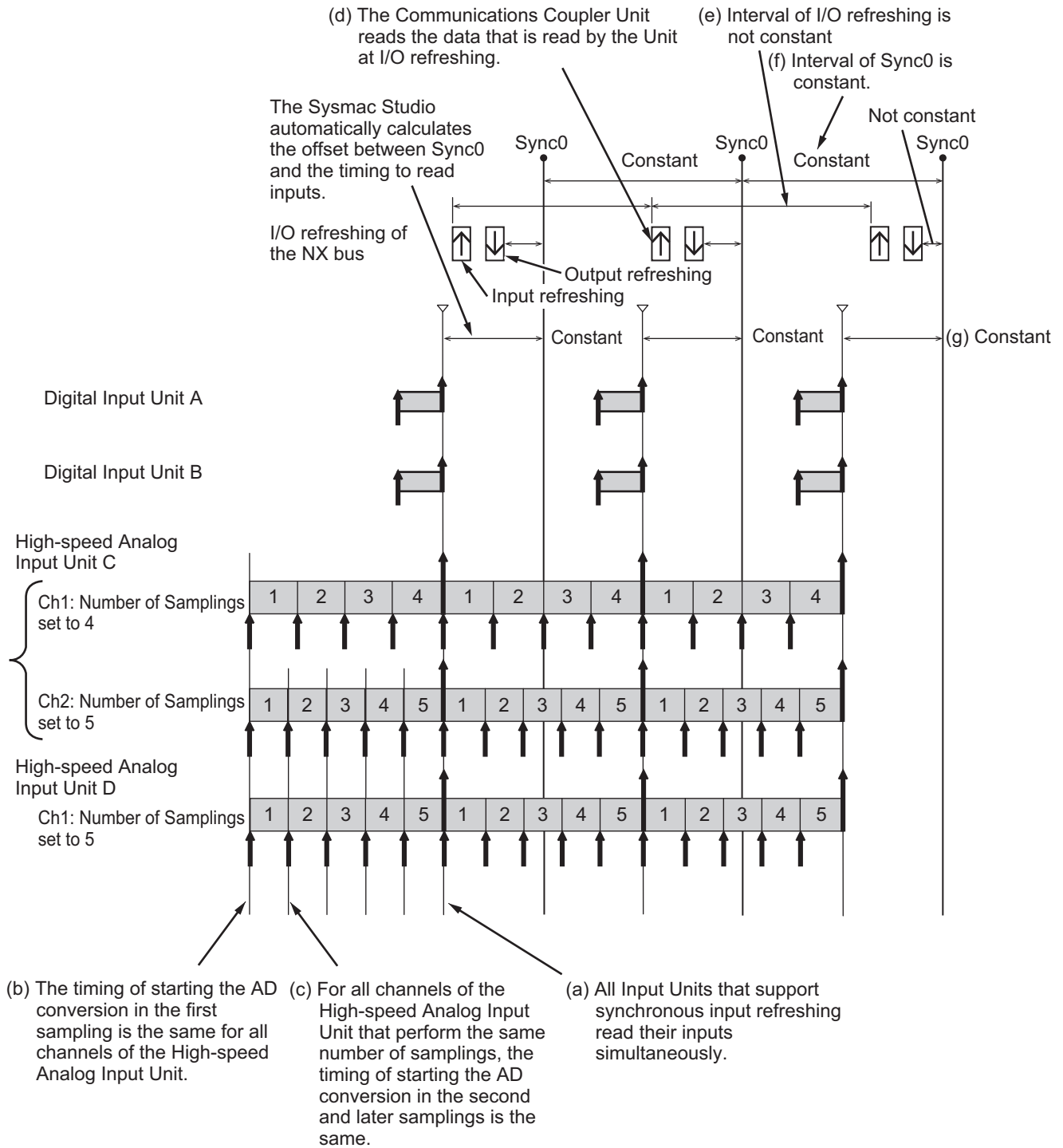

6

Input Range and Converted Values

This section describes the input range of the High-speed Analog Input Units and the converted values.

6-1	Voltage Input Range and Converted Values	6-2
6-2	Current Input Range and Converted Values	6-5

6-1 Voltage Input Range and Converted Values

Analog voltage input signals are converted to digital values according to the input range shown below. If the input range exceeds the value range for which conversion is possible, the converted value is fixed at the upper or lower limit.

Input Range: -10 to 10 V

A voltage of -10 to 10 V is converted to a signed integer value (-32000 to 32000).

The resolution is 1/64000.

The input voltage range for which conversion is possible is -10.2 to 10.2 V and the converted value is a signed integer value (-32640 to 32640).

The disconnection detection function is not supported.

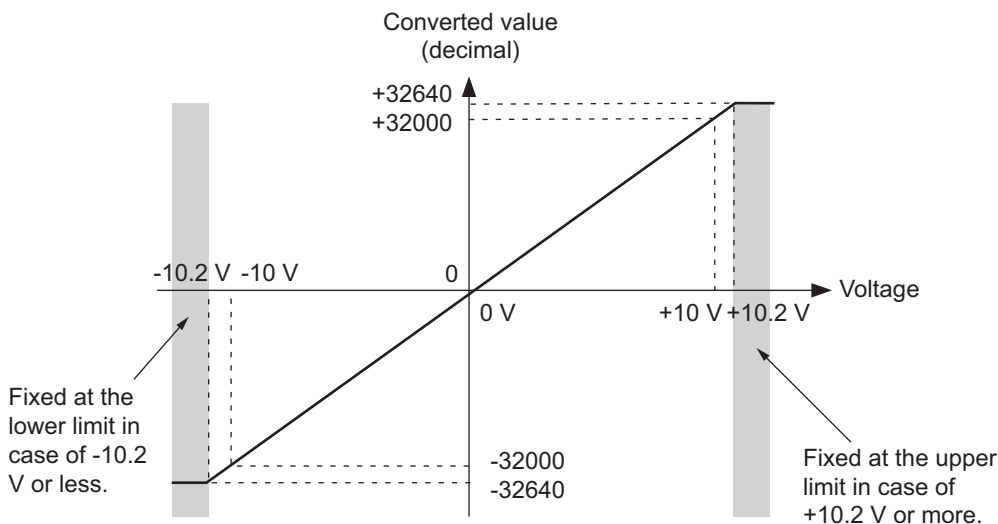

Input Range: -5 to 5 V

A voltage of -5 to 5 V is converted to a signed integer value (-32000 to 32000).

The resolution is 1/64000.

The input voltage range for which conversion is possible is -5.1 to 5.1 V and the converted value is a signed integer value (-32640 to 32640).

The disconnection detection function is not supported.

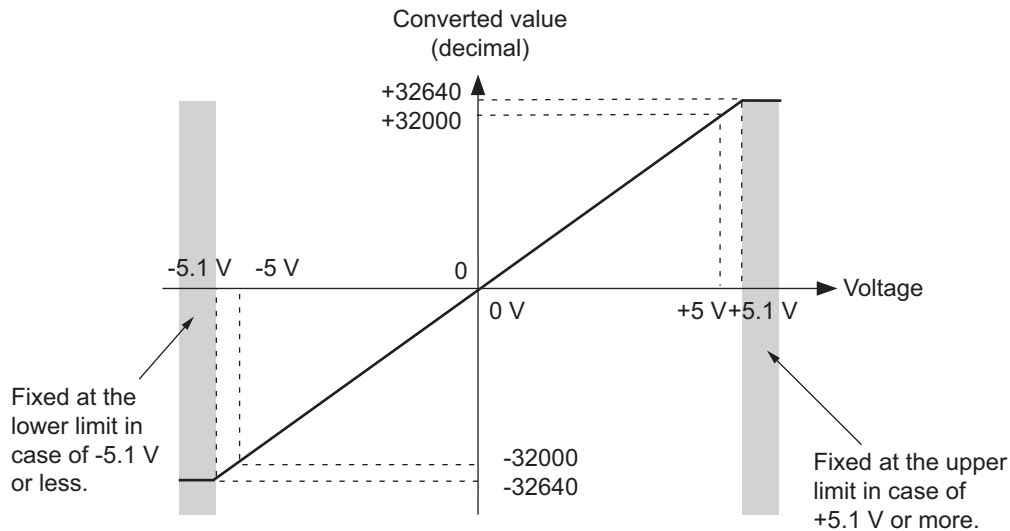

Input Range: 0 to 10 V

A voltage of 0 to 10 V is converted to a signed integer value (0 to 32000).

The resolution is 1/32000.

The input voltage range for which conversion is possible is -0.2 to 10.2 V and the converted value is a signed integer value (-640 to 32640).

The disconnection detection function is not supported.

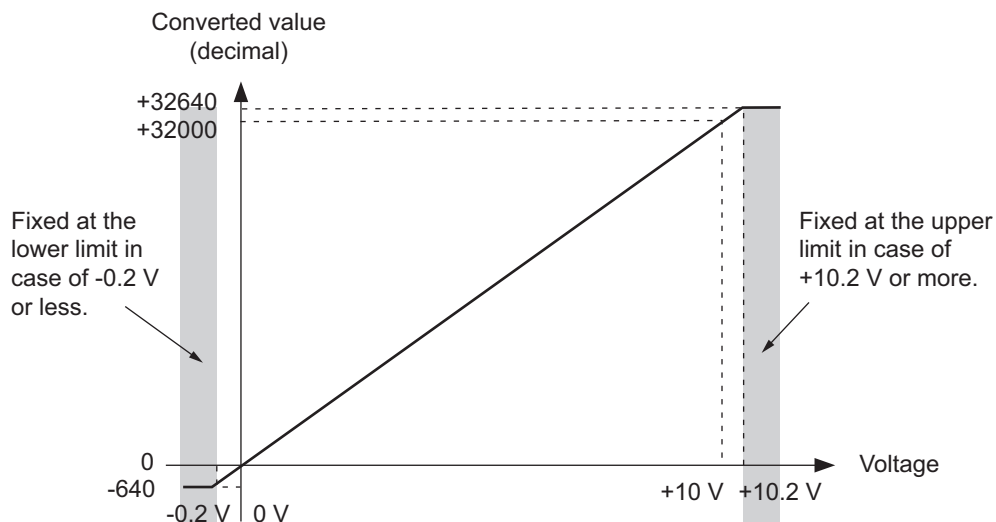

Input Range: 0 to 5 V

A voltage of 0 to 5 V is converted to a signed integer value (0 to 32000).

The resolution is 1/32000.

The input voltage range for which conversion is possible is -0.1 to 5.1 V and the converted value is a signed integer value (-640 to 32640).

The disconnection detection function is not supported.

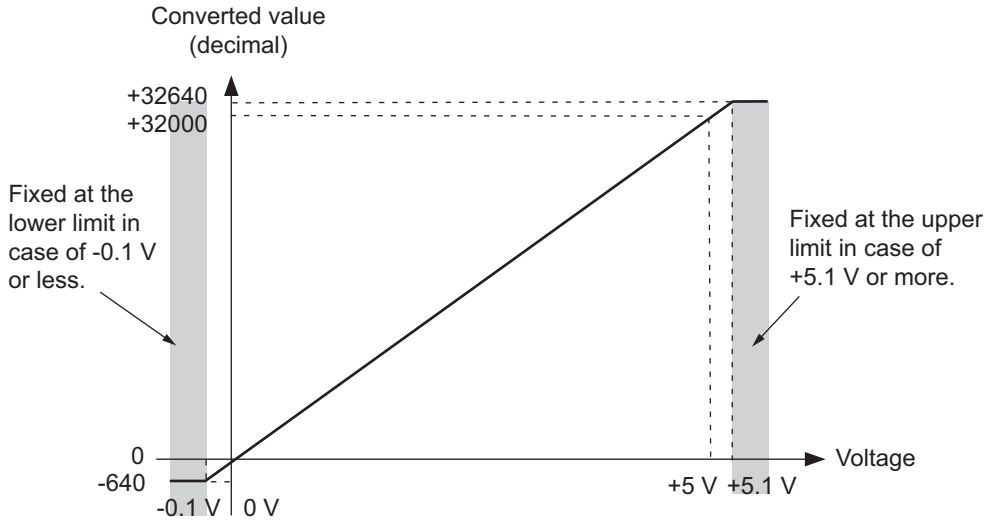

Input Range: 1 to 5 V

A voltage of 1 to 5 V is converted to a signed integer value (0 to 32000).

The resolution is 1/32000.

The input voltage range for which conversion is possible is 0.92 to 5.08 V and the converted value is a signed integer value (-640 to 32640).

If the input value falls below the input range such as for a disconnection, and the input voltage is less than 0.3 V, the disconnection detection function activates. At this time, the converted value will be 32767.

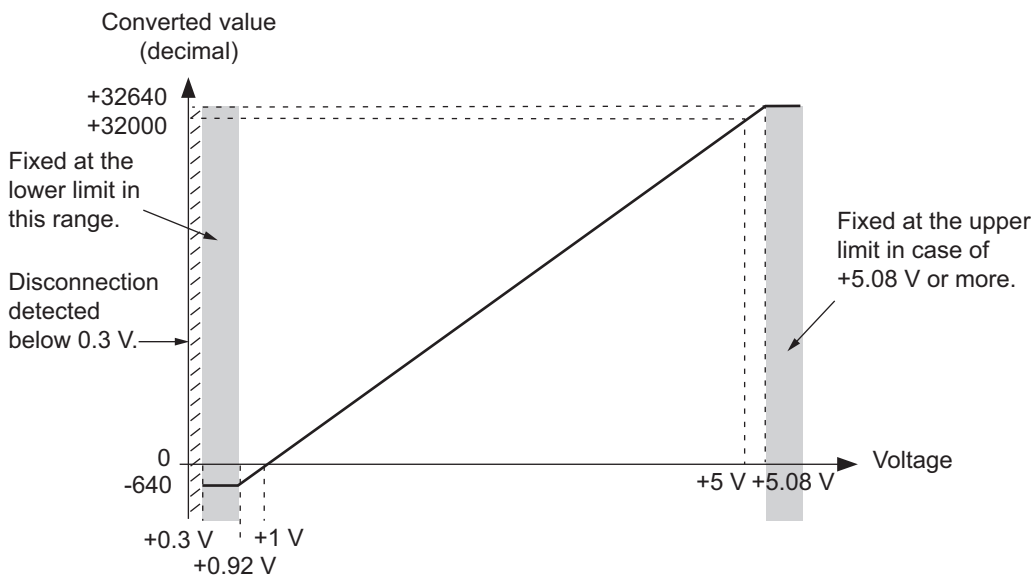

6-2 Current Input Range and Converted Values

Analog current input signals are converted to digital values according to the input range shown below. If the input range exceeds the value range for which conversion is possible, the converted value is fixed at the upper or lower limit.

Input Range: 0 to 20 mA

A current of 0 to 20 mA is converted to a signed integer value (0 to 32000).

The resolution is 1/32000.

The input current range for which conversion is possible is -0.4 to 20.4 mA and the converted value is a signed integer value (-640 to 32640).

The disconnection detection function is not supported.

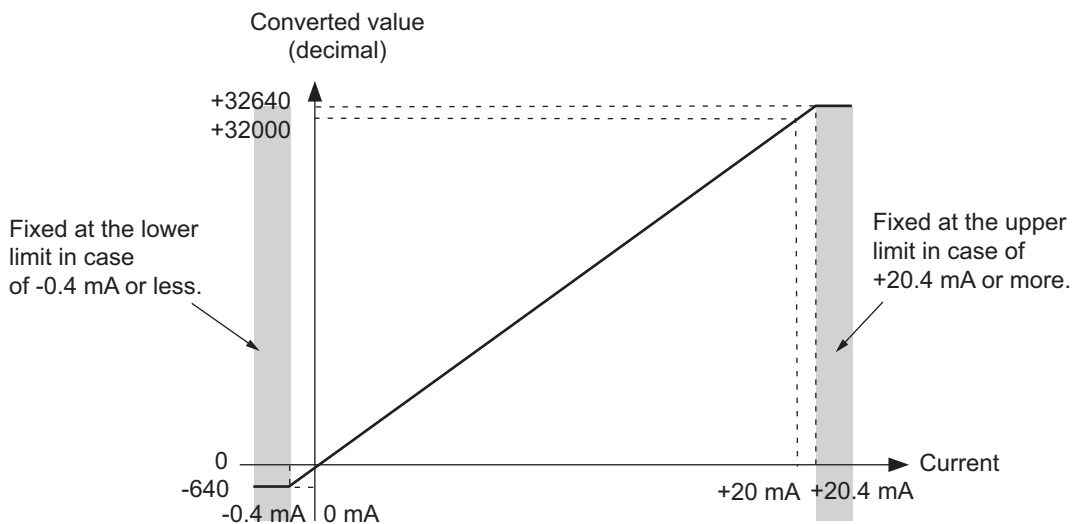

Input Range: 4 to 20 mA

A current of 4 to 20 mA is converted to a signed integer value (0 to 32000).

The resolution is 1/32000.

The input current range for which conversion is possible is 3.68 to 20.32 mA and the converted value is a signed integer value (-640 to 32640).

If the input value falls below the input range such as for a disconnection, and the input current is less than 1.2 mA, the disconnection detection function activates. At this time, the converted value will be 32767.

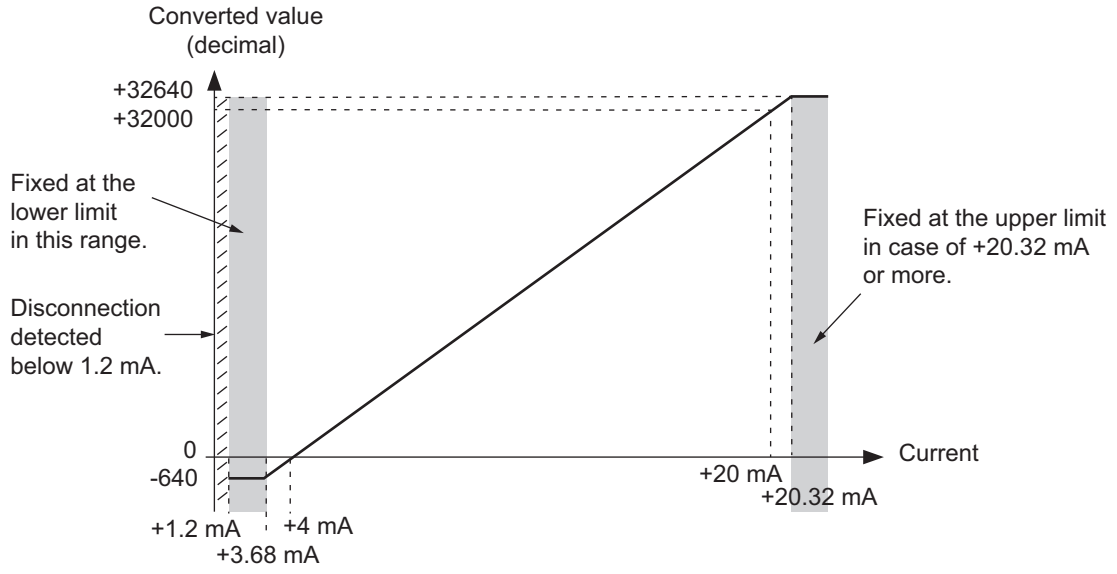

7

I/O Data and List of Settings

This section describes the I/O data and provides a list of settings for the High-speed Analog Input Units.

7-1	Specifications of I/O Data	7-2
7-1-1	Allocatable I/O Data	7-2
7-1-2	Data Details	7-6
7-1-3	Precautions for the I/O Data Size	7-12
7-2	Setting I/O Allocations with the Sysmac Studio.....	7-14
7-2-1	Displaying the Edit I/O Allocation Settings Window	7-14
7-2-2	Displayed I/O Allocation Settings	7-16
7-2-3	Configuring the I/O Allocation Settings.....	7-18
7-3	List of Settings	7-20

7-1 Specifications of I/O Data

This section describes the I/O data for the High-speed Analog Input Units and provides precautions for the I/O data size.

7-1-1 Allocatable I/O Data

Eight I/O entry mappings are assigned to the I/O allocation settings for the High-speed Analog Input Units. The I/O entries for the High-speed Analog Input Units are assigned to the I/O entry mappings. An I/O entry means the I/O data described in this section. An I/O entry mapping means a collection of I/O entries.

For the High-speed Analog Input Units, the allocation of I/O entry mappings is fixed.

When you click the **Update I/O Entry** Button in the Edit I/O Allocation Settings Window on the Sysmac Studio, required I/O entries are automatically assigned for the High-speed Analog Input Units, based on the following settings:

- Ch□ Enable/Disable
- Ch□ Number of Samplings Setting

When you assign the I/O allocation information of the NX Unit or EtherCAT Slave Terminal to an NJ/NX-series CPU Unit or NY-series Industrial PC, use the I/O ports for the allocated I/O data.

This section shows I/O data that can be allocated to the High-speed Analog Input Units, and an example of I/O entry allocation.

Allocatable I/O Data

This section describes I/O data that can be allocated.

Area	I/O entry mapping name	Data name	Size (Byte)	Data type	Registered by default *1	I/O entry that changes according to Unit operation settings	Reference
Input	Input Data Set 1	Analog Input Time Stamp	8	ULINT	Yes	---	<i>Analog Input Time Stamp</i> on page 7-7
		Ch1 Status	2	WORD	Yes	Yes	<i>Ch□ Status</i> on page 7-7
		Ch1 Trigger Input Time Stamp	8	ULINT	Yes	Yes	<i>Ch□ Trigger Input Time Stamp</i> on page 7-8
		Ch1 Number of Samplings	2	UINT	Yes	Yes	<i>Ch□ Number of Samplings</i> on page 7-9
		Ch1 Analog Input Value 1-10	20	ARRAY[0..9] OF INT	Yes	Yes	<i>Ch□ Analog Input Value</i> on page 7-9
		Ch1 Analog Input Value 11-20	20	ARRAY[0..9] OF INT	---	Yes	
		:	:	:	:	:	
	Ch1 Analog Input Value 991-1000	20	ARRAY[0..9] OF INT	---	Yes		
	Input Data Set 2	Ch2 Status	2	WORD	Yes	Yes	<i>Ch□ Status</i> on page 7-7
		Ch2 Trigger Input Time Stamp	8	ULINT	Yes	Yes	<i>Ch□ Trigger Input Time Stamp</i> on page 7-8
		Ch2 Number of Samplings	2	UINT	Yes	Yes	<i>Ch□ Number of Samplings</i> on page 7-9
		Ch2 Analog Input Value 1-10	20	ARRAY[0..9] OF INT	Yes	Yes	<i>Ch□ Analog Input Value</i> on page 7-9
		Ch2 Analog Input Value 11-20	20	ARRAY[0..9] OF INT	---	Yes	
		:	:	:	:	:	
Ch2 Analog Input Value 991-1000		20	ARRAY[0..9] OF INT	---	Yes		

Area	I/O entry mapping name	Data name	Size (Byte)	Data type	Registered by default *1	I/O entry that changes according to Unit operation settings	Reference	
Input	Input Data Set 3	Ch3 Status	2	WORD	Yes	Yes	<i>Ch□ Status</i> on page 7-7	
		Ch3 Trigger Input Time Stamp	8	ULINT	Yes	Yes		<i>Ch□ Trigger Input Time Stamp</i> on page 7-8
		Ch3 Number of Samplings	2	UINT	Yes	Yes		<i>Ch□ Number of Samplings</i> on page 7-9
		Ch3 Analog Input Value 1-10	20	ARRAY[0..9] OF INT	Yes	Yes		<i>Ch□ Analog Input Value</i> on page 7-9
		Ch3 Analog Input Value 11-20	20	ARRAY[0..9] OF INT	---	Yes		
		:	:	:	:	:		
		Ch3 Analog Input Value 991-1000	20	ARRAY[0..9] OF INT	---	Yes		
	Input Data Set 4	Ch4 Status	2	WORD	Yes	Yes	<i>Ch□ Status</i> on page 7-7	
		Ch4 Trigger Input Time Stamp	8	ULINT	Yes	Yes	<i>Ch□ Trigger Input Time Stamp</i> on page 7-8	
		Ch4 Number of Samplings	2	UINT	Yes	Yes	<i>Ch□ Number of Samplings</i> on page 7-9	
		Ch4 Analog Input Value 1-10	20	ARRAY[0..9] OF INT	Yes	Yes	<i>Ch□ Analog Input Value</i> on page 7-9	
		Ch4 Analog Input Value 11-20	20	ARRAY[0..9] OF INT	---	Yes		
		:	:	:	:	:		
		Ch4 Analog Input Value 991-1000	20	ARRAY[0..9] OF INT	---	Yes		
Output	Output Data Set 1	Ch1 Operation Command	2	WORD	Yes	Yes	<i>Ch□ Operation Command</i> on page 7-11	
	Output Data Set 2	Ch2 Operation Command	2	WORD	Yes	Yes		
	Output Data Set 3	Ch3 Operation Command	2	WORD	Yes	Yes		
	Output Data Set 4	Ch4 Operation Command	2	WORD	Yes	Yes		

*1. The I/O data items are registered as the factory settings.

Example of I/O Entry Allocation

The allocation of an I/O entry changes according to the **Ch□ Enable/Disable** and **Ch□ Number of Samplings Setting** that you set in the Unit operation settings. The following table shows an example of I/O entry allocation that matches the set values of the Unit operation settings.

Area	I/O entry mapping name	Data name	I/O entry to be allocated		
			<ul style="list-style-type: none"> • Ch□ Enable/Disable All channels: Enable • Ch□ Number of Samplings Setting All channels: 10 times 	<ul style="list-style-type: none"> • Ch□ Enable/Disable All channels: Enable • Ch□ Number of Samplings Setting All channels: 5 times 	<ul style="list-style-type: none"> • Ch□ Enable/Disable Ch1: Enable Other channels: Disable • Ch□ Number of Samplings Setting Ch1: 1000 times Other channels: 1 time
Input	Input Data Set 1	Analog Input Time Stamp	Yes	Yes	Yes
		Ch1 Status	Yes	Yes	Yes
		Ch1 Trigger Input Time Stamp	Yes	Yes	Yes
		Ch1 Number of Samplings	Yes	Yes	Yes
		Ch1 Analog Input Value 1-10	Yes	Yes	Yes
		Ch1 Analog Input Value 11-20	---	---	Yes
		:	:	:	:
	Ch1 Analog Input Value 991-1000	---	---	Yes	
	Input Data Set 2	Ch2 Status	Yes	Yes	---
		Ch2 Trigger Input Time Stamp	Yes	Yes	---
		Ch2 Number of Samplings	Yes	Yes	---
		Ch2 Analog Input Value 1-10	Yes	Yes	---
		Ch2 Analog Input Value 11-20	---	---	---
		:	:	:	:
Ch2 Analog Input Value 991-1000		---	---	---	

Area	I/O entry mapping name	Data name	I/O entry to be allocated		
			<ul style="list-style-type: none"> • Ch□ Enable/Disable All channels: Enable • Ch□ Number of Samplings Setting All channels: 10 times 	<ul style="list-style-type: none"> • Ch□ Enable/Disable All channels: Enable • Ch□ Number of Samplings Setting All channels: 5 times 	<ul style="list-style-type: none"> • Ch□ Enable/Disable Ch1: Enable Other channels: Disable • Ch□ Number of Samplings Setting Ch1: 1000 times Other channels: 1 time
Input	Input Data Set 3	Ch3 Status	Yes	Yes	---
		Ch3 Trigger Input Time Stamp	Yes	Yes	---
		Ch3 Number of Samplings	Yes	Yes	---
		Ch3 Analog Input Value 1-10	Yes	Yes	---
		Ch3 Analog Input Value 11-20	---	---	---
		:	:	:	:
		Ch3 Analog Input Value 991-1000	---	---	---
	Input Data Set 4	Ch4 Status	Yes	Yes	---
		Ch4 Trigger Input Time Stamp	Yes	Yes	---
		Ch4 Number of Samplings	Yes	Yes	---
		Ch4 Analog Input Value 1-10	Yes	Yes	---
		Ch4 Analog Input Value 11-20	---	---	---
		:	:	:	:
		Ch4 Analog Input Value 991-1000	---	---	---
Output	Output Data Set 1	Ch1 Operation Command	Yes	Yes	Yes
	Output Data Set 2	Ch2 Operation Command	Yes	Yes	---
	Output Data Set 3	Ch3 Operation Command	Yes	Yes	---
	Output Data Set 4	Ch4 Operation Command	Yes	Yes	---

Refer to 7-2 *Setting I/O Allocations with the Sysmac Studio* on page 7-14 for details on setting I/O allocations with the Support Software.

7-1-2 Data Details

This section describes the data items for I/O allocation and their configurations. The default values show the factory settings. After the power is turned ON, the default values of I/O data in the input area will be updated according to the Unit operation settings and the connection status with external devices.

Analog Input Time Stamp

This indicates the DC time at which AD conversion starts in the first sampling of analog input data during each task period. The timing of starting the AD conversion is the same for all the channels.

Data name	Data type	Default value	I/O port name	Unit	Index number (hex)	Subindex number (hex)
Analog Input Time Stamp	ULINT	0	Analog Input Time Stamp	ns	6000	01

The bit configuration of the Analog Input Time Stamp (ULINT) is given in the following table.

Byte	Bit 7	Bit 6	Bit 5	Bit 4	Bit 3	Bit 2	Bit 1	Bit 0
0	Analog Input Time Stamp, 1st byte							
+1	Analog Input Time Stamp, 2nd byte							
+2	Analog Input Time Stamp, 3rd byte							
+3	Analog Input Time Stamp, 4th byte							
+4	Analog Input Time Stamp, 5th byte							
+5	Analog Input Time Stamp, 6th byte							
+6	Analog Input Time Stamp, 7th byte							
+7	Analog Input Time Stamp, 8th byte							

The following figure shows the timing of obtaining data.

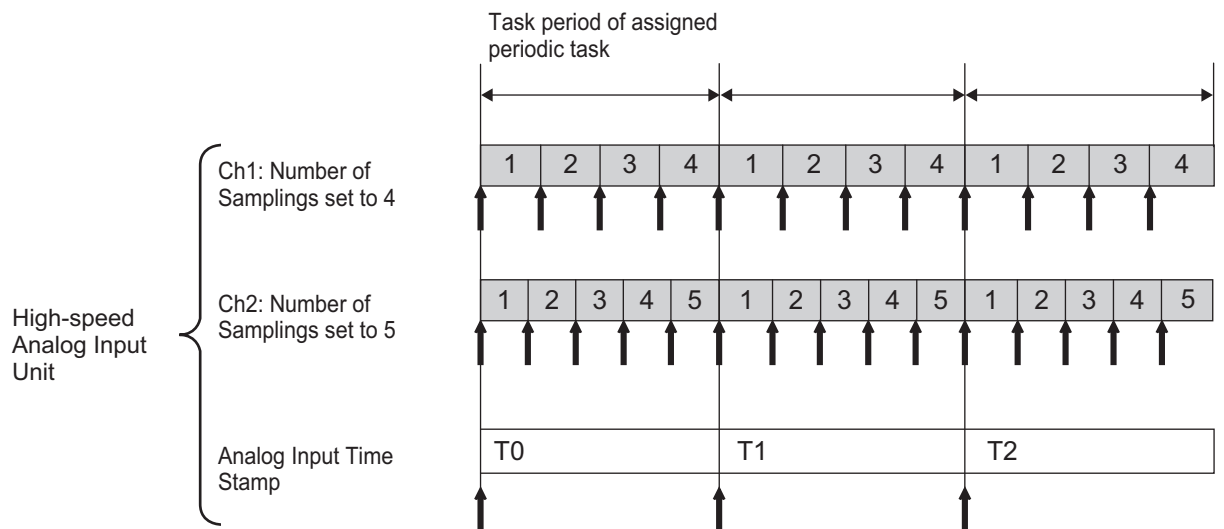

Records the DC time at which AD conversion starts in the first sampling of analog input data during each task period.

Ch□ Status

This is aggregated Status data that the High-speed Analog Input Units detect, such as I/O Disconnection Detected and Under Range.

Data name	Data type	Default value	I/O port name	Unit	Index number (hex)	Subindex number (hex)
Ch1 Status	WORD	0000 hex	Ch1 Status	---	6001	01
Ch2 Status	WORD	0000 hex	Ch2 Status	---	6002	01

Data name	Data type	Default value	I/O port name	Unit	Index number (hex)	Subindex number (hex)
Ch3 Status	WORD	0000 hex	Ch3 Status	---	6003	01
Ch4 Status	WORD	0000 hex	Ch4 Status	---	6004	01

The bit configuration and the description of each bit for the Ch□ Status are given in the following table.

Bit	Data name	Description*1	Data type	I/O port name
0	Ch□ Disconnection Detection Status	1: A disconnection was detected. 0: A disconnection was not detected.	BOOL	Ch□ Disconnection Detection Status
1	Ch□ Under Range	1: An under range was detected. 0: An under range was not detected.	BOOL	Ch□ Under Range
2	Ch□ Over Range	1: An over range was detected. 0: An over range was not detected.	BOOL	Ch□ Over Range
3	Ch□ Digital Low-pass Filter Disabled	1: The digital low-pass filter is disabled. 0: The digital low-pass filter is enabled.	BOOL	Ch□ Digital Low-pass Filter Disabled
4	Ch□ Moving Average Filter 1 Disabled	1: The moving average filter 1 is disabled. Or it has not reached the average count. 0: The moving average filter 1 is enabled.	BOOL	Ch□ Moving Average Filter 1 Disabled
5	Ch□ Moving Average Filter 2 Disabled	1: The moving average filter 2 is disabled. Or it has not reached the average count. 0: The moving average filter 2 is enabled.	BOOL	Ch□ Moving Average Filter 2 Disabled
6	Ch□ Zero Set Executing	1: The zero set is in progress. 0: The zero set is not in progress.	BOOL	Ch□ Zero Set Executing
7	Ch□ Trigger Input	1: The trigger input is ON. 0: The trigger input is OFF.	BOOL	Ch□ Trigger Input
8 to 15	Ch□ Reserved	---	---	---

*1. 1 is TRUE and 0 is FALSE.

Ch□ Trigger Input Time Stamp

This indicates the DC time at which the trigger input changes from OFF to ON during the NX bus I/O refresh cycle. If the trigger input changes from OFF to ON more than once during the cycle, the DC time at the first change is recorded. Refer to *8-10 Trigger Input* on page 8-40 for details on the applications of this data and the timing when it is obtained.

Data name	Data type	Default value	I/O port name	Unit	Index number (hex)	Subindex number (hex)
Ch1 Trigger Input Time Stamp	ULINT	0	Ch1 Trigger Input Time Stamp	ns	6001	02
Ch2 Trigger Input Time Stamp	ULINT	0	Ch2 Trigger Input Time Stamp	ns	6002	02
Ch3 Trigger Input Time Stamp	ULINT	0	Ch3 Trigger Input Time Stamp	ns	6003	02
Ch4 Trigger Input Time Stamp	ULINT	0	Ch4 Trigger Input Time Stamp	ns	6004	02

The bit configuration of the Ch□ Trigger Input Time Stamp (ULINT) is given in the following table.

Byte	Bit 7	Bit 6	Bit 5	Bit 4	Bit 3	Bit 2	Bit 1	Bit 0
0	Ch□ Trigger Input Time Stamp, 1st byte							
+1	Ch□ Trigger Input Time Stamp, 2nd byte							
+2	Ch□ Trigger Input Time Stamp, 3rd byte							
+3	Ch□ Trigger Input Time Stamp, 4th byte							
+4	Ch□ Trigger Input Time Stamp, 5th byte							
+5	Ch□ Trigger Input Time Stamp, 6th byte							
+6	Ch□ Trigger Input Time Stamp, 7th byte							
+7	Ch□ Trigger Input Time Stamp, 8th byte							

Ch□ Number of Samplings

This indicates the number of samplings of analog input data per task period. You can change the sampling period by setting the number of samplings. Refer to *8-4 Number of Samplings Setting* on page 8-8 for details.

Data name	Data type	Default value	I/O port name	Unit	Index number (hex)	Subindex number (hex)
Ch1 Number of Samplings	UINT	1	Ch1 Number of Sampling	---	6001	03
Ch2 Number of Samplings	UINT	1	Ch2 Number of Sampling	---	6002	03
Ch3 Number of Samplings	UINT	1	Ch3 Number of Sampling	---	6003	03
Ch4 Number of Samplings	UINT	1	Ch4 Number of Sampling	---	6004	03

The bit configuration of the Ch□ Number of Samplings (UINT) is given in the following table.

Byte	Bit 7	Bit 6	Bit 5	Bit 4	Bit 3	Bit 2	Bit 1	Bit 0
0	Ch□ Number of Samplings, 1st byte							
+1	Ch□ Number of Samplings, 2nd byte							

Ch□ Analog Input Value

This indicates the analog input values that are sampled per task period.

The numeric suffix at the end of the data name indicates the corresponding sampling order. For example, “11-20” means that the analog input value was obtained between the 11th to 20th samplings.

In addition, the input value of analog input data takes the default value 0, if it exceeds the set number of samplings. For example, if the number of samplings is set to 25, the value of the analog input value 26 to 30 in Ch□analog input value 21-30 is 0.

Data name	Data type	Default value	I/O port name	Unit	Index number (hex)	Subindex number (hex)
Ch1 Analog Input Value 1-10	ARRAY[0..9] OF INT	0	Ch1 Analog Input Value 1-10	---	6001	04
Ch1 Analog Input Value 11-20	ARRAY[0..9] OF INT	0	Ch1 Analog Input Value 11-20	---	6001	05

Data name	Data type	Default value	I/O port name	Unit	Index number (hex)	Subindex number (hex)
:	:	:	:	:	:	:
Ch1 Analog Input Value 991-1000	ARRAY[0..9] OF INT	0	Ch1 Analog Input Value 991-1000	---	6001	67
Ch2 Analog Input Value 1-10	ARRAY[0..9] OF INT	0	Ch2 Analog Input Value 1-10	---	6002	04
Ch2 Analog Input Value 11-20	ARRAY[0..9] OF INT	0	Ch2 Analog Input Value 11-20	---	6002	05
:	:	:	:	:	:	:
Ch2 Analog Input Value 991-1000	ARRAY[0..9] OF INT	0	Ch2 Analog Input Value 991-1000	---	6002	67
Ch3 Analog Input Value 1-10	ARRAY[0..9] OF INT	0	Ch3 Analog Input Value 1-10	---	6003	04
Ch3 Analog Input Value 11-20	ARRAY[0..9] OF INT	0	Ch3 Analog Input Value 11-20	---	6003	05
:	:	:	:	:	:	:
Ch3 Analog Input Value 991-1000	ARRAY[0..9] OF INT	0	Ch3 Analog Input Value 991-1000	---	6003	67
Ch4 Analog Input Value 1-10	ARRAY[0..9] OF INT	0	Ch4 Analog Input Value 1-10	---	6004	04
Ch4 Analog Input Value 11-20	ARRAY[0..9] OF INT	0	Ch4 Analog Input Value 11-20	---	6004	05
:	:	:	:	:	:	:
Ch4 Analog Input Value 991-1000	ARRAY[0..9] OF INT	0	Ch4 Analog Input Value 991-1000	---	6004	67

The bit configuration of the Ch□ Analog Input Value 1-10 (ARRAY[0..9] OF INT) is given in the following table.

Byte	Bit 7	Bit 6	Bit 5	Bit 4	Bit 3	Bit 2	Bit 1	Bit 0
0	1st byte of Analog Input Value 1 in Ch□ Analog Input Value 1-10							
+1	2nd byte of Analog Input Value 1 in Ch□ Analog Input Value 1-10							
+2	1st byte of Analog Input Value 2 in Ch□ Analog Input Value 1-10							
+3	2nd byte of Analog Input Value 2 in Ch□ Analog Input Value 1-10							
+4	1st byte of Analog Input Value 3 in Ch□ Analog Input Value 1-10							
+5	2nd byte of Analog Input Value 3 in Ch□ Analog Input Value 1-10							
:	:							
+18	1st byte of Analog Input Value 10 in Ch□ Analog Input Value 1-10							
+19	2nd byte of Analog Input Value 10 in Ch□ Analog Input Value 1-10							

The bit configuration of the Ch□ Analog Input Value 11-20 (ARRAY[0..9] OF INT) is given in the following table.

Byte	Bit 7	Bit 6	Bit 5	Bit 4	Bit 3	Bit 2	Bit 1	Bit 0
0	1st byte of Analog Input Value 11 in Ch□ Analog Input Value 11-20							
+1	2nd byte of Analog Input Value 11 in Ch□ Analog Input Value 11-20							
+2	1st byte of Analog Input Value 12 in Ch□ Analog Input Value 11-20							
+3	2nd byte of Analog Input Value 12 in Ch□ Analog Input Value 11-20							
+4	1st byte of Analog Input Value 13 in Ch□ Analog Input Value 11-20							
+5	2nd byte of Analog Input Value 13 in Ch□ Analog Input Value 11-20							

Byte	Bit 7	Bit 6	Bit 5	Bit 4	Bit 3	Bit 2	Bit 1	Bit 0
:	:							
+18	1st byte of Analog Input Value 20 in Ch□ Analog Input Value 11-20							
+19	2nd byte of Analog Input Value 20 in Ch□ Analog Input Value 11-20							

The bit configuration of the Ch□ Analog Input Value 991-1000 (ARRAY[0..9] OF INT) is given in the following table.

Byte	Bit 7	Bit 6	Bit 5	Bit 4	Bit 3	Bit 2	Bit 1	Bit 0
0	1st byte of Analog Input Value 991 in Ch□ Analog Input Value 991-1000							
+1	2nd byte of Analog Input Value 991 in Ch□ Analog Input Value 991-1000							
+2	1st byte of Analog Input Value 992 in Ch□ Analog Input Value 991-1000							
+3	2nd byte of Analog Input Value 992 in Ch□ Analog Input Value 991-1000							
+4	1st byte of Analog Input Value 993 in Ch□ Analog Input Value 991-1000							
+5	2nd byte of Analog Input Value 993 in Ch□ Analog Input Value 991-1000							
:	:							
+18	1st byte of Analog Input Value 1000 in Ch□ Analog Input Value 991-1000							
+19	2nd byte of Analog Input Value 1000 in Ch□ Analog Input Value 991-1000							

Ch□ Operation Command

This is aggregated Operation Command data that the High-speed Analog Input Units use to execute functions such as Digital Low-pass Filter Disable and Zero Set Execution.

Data name	Data type	Default value	I/O port name	Unit	Index number (hex)	Subindex number (hex)
Ch1 Operation Command	WORD	0000 hex	Ch1 Operation Command	---	7000	01
Ch2 Operation Command	WORD	0000 hex	Ch2 Operation Command	---	7001	01
Ch3 Operation Command	WORD	0000 hex	Ch3 Operation Command	---	7002	01
Ch4 Operation Command	WORD	0000 hex	Ch4 Operation Command	---	7003	01

The bit configuration and the description of each bit for the Ch□ Operation Command are given in the following table.

Bit	Data name	Description*1	Data type	I/O port name
0	Ch□ Digital Low-pass Filter Disable	1: Disables the digital low-pass filter. 0: Enables the digital low-pass filter. If the low-pass filter frequency is set to 0 in the Unit operation settings, the digital low-pass filter will not be enabled even if you set this bit to 0.	BOOL	Ch□ Digital Low-pass Filter Disable

Bit	Data name	Description*1	Data type	I/O port name
1	Ch□ Moving Average Filter 1 Disable	1: Disables the moving average filter 1. 0: Enables the moving average filter 1. If the Filter 1 Moving Average Count is set to 0 in the Unit operation settings, the moving average filter 1 will not be enabled even if you set this bit to 0.	BOOL	Ch□ Moving Average Filter 1 Disable
2	Ch□ Moving Average Filter 2 Disable	1: Disables the moving average filter 2. 0: Enables the moving average filter 2. If the Filter 2 Moving Average Count is set to 0 in the Unit operation settings, the moving average filter 2 will not be enabled even if you set this bit to 0.	BOOL	Ch□ Moving Average Filter 2 Disable
3	Ch□ Zero Set Execution	0→1: Executes the zero set. 1→0: Executes the zero reset.	BOOL	Ch□ Zero Set Execution
4 to 15	Ch□ Reserved	---	---	---

*1. 1 is TRUE and 0 is FALSE.



Precautions for Correct Use

Do not access reserved data. Doing so may cause unintended operation if some function is assigned to the reserved data in an upgrade.

7-1-3 Precautions for the I/O Data Size

The input data size of the High-speed Analog Input Unit will increase as the set value for **Ch□ Number of Samplings Setting** increases. For example, when all the channels are enabled, and the number of samplings for each channel is set to 10, 50, 100, and 200, the input data size is as follows. The table shows that the input data size increases as the number of samplings increases.

Number of samplings for each channel	Input data size
10 times	136 bytes
50 times	456 bytes
100 times	856 bytes
200 times	1,656 bytes

At this time, you should consider the restrictions given in the table below.

Item	Description
Size of NX Unit I/O data that can be allocated to the CPU Unit or Communications Coupler Unit	<p>There are restrictions on the size of NX Unit I/O data that can be allocated to the CPU or Communications Coupler Unit connected to a High-speed Analog Input Unit.*1 For example, the size of I/O data for an NX102 CPU Unit will be restricted as below:</p> <ul style="list-style-type: none"> • Input: 8,192 bytes • Output: 8,192 bytes <p>Refer to the software user's manual for the connected CPU Unit or the user's manual for the Communications Coupler Unit for restriction on the allocatable I/O data size for the CPU Unit or Communications Coupler Unit.</p>

Item	Description
Size of I/O data that can be allocated to a High-speed Analog Input Unit	The size of I/O data that can be allocated to a single High-speed Analog Input Unit is restricted as below. <ul style="list-style-type: none">• Input: 2,048 bytes• Output: 2,048 bytes

- *1. When the Unit is connected to a Communications Coupler Unit, the restrictions apply to the I/O data size of the entire slave terminal including the Communications Coupler Unit.

7-2 Setting I/O Allocations with the Sysmac Studio

Configure the I/O allocation settings of the High-speed Analog Input Unit from the Sysmac Studio. This section describes how to display the Edit I/O Allocation Settings Window, information to be displayed, and how to configure the I/O allocation settings.

7-2-1 Displaying the Edit I/O Allocation Settings Window

Connected to a CPU Unit

This section describes how to display the Edit I/O Allocation Settings Window for a High-speed Analog Input Unit connected to a CPU Unit.

- 1 In the Multiview Explorer, double-click the CPU Rack to which the target High-speed Analog Input Unit is connected to open the CPU and Expansion Racks Tab Page. The following tab page is displayed.

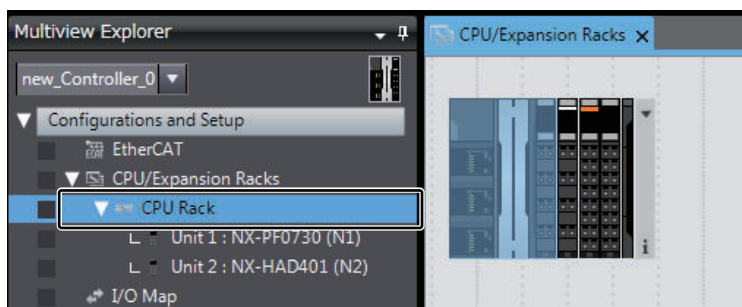

- 2 Select the High-speed Analog Input Unit on the CPU and Expansion Racks Tab Page. In the Unit Settings Pane, click the **Edit I/O Allocation Settings** Button.

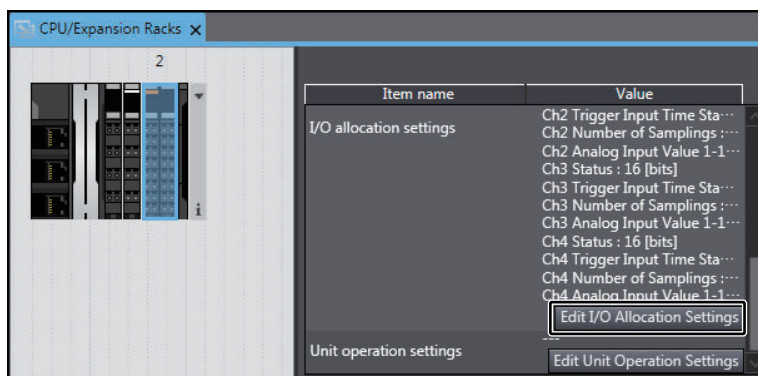

The Edit I/O Allocation Settings Window is displayed.

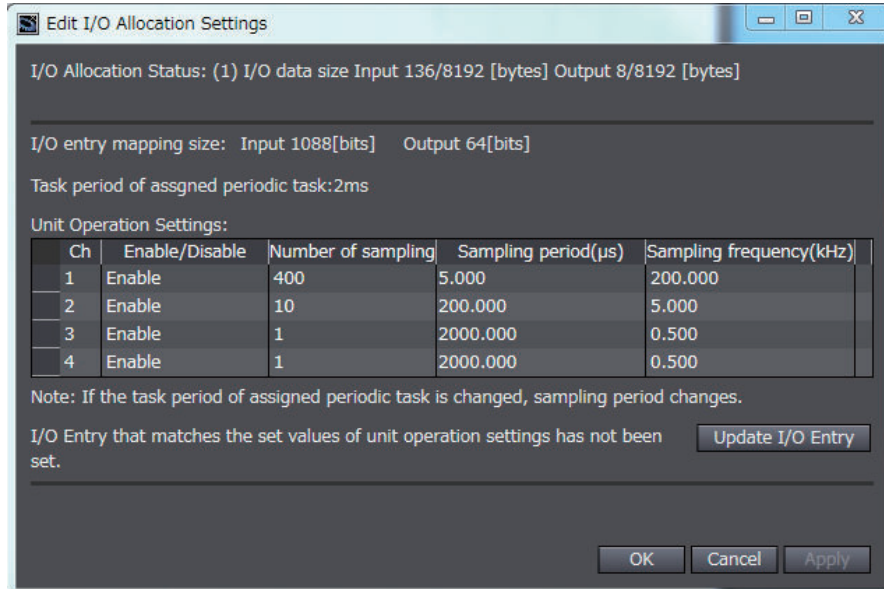

Slave Terminal

This section describes how to display the Edit I/O Allocation Settings Window for a High-speed Analog Input Unit connected to a Communications Coupler Unit.

- 1 In the Multiview Explorer, double-click the Communications Coupler Unit to which the target High-speed Analog Input Unit is connected to open the Edit Slave Terminal Configuration Tab Page.

The following tab page is displayed.

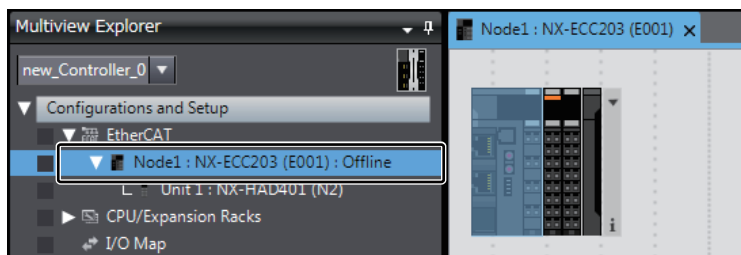

- 2 Select the High-speed Analog Input Unit on the Edit Slave Terminal Configuration Tab Page. In the Unit Settings Pane, click the **Edit I/O Allocation Settings** Button.

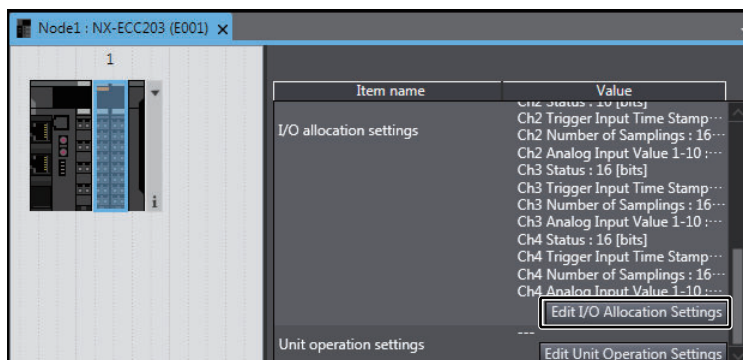

The Edit I/O Allocation Settings Window is displayed.

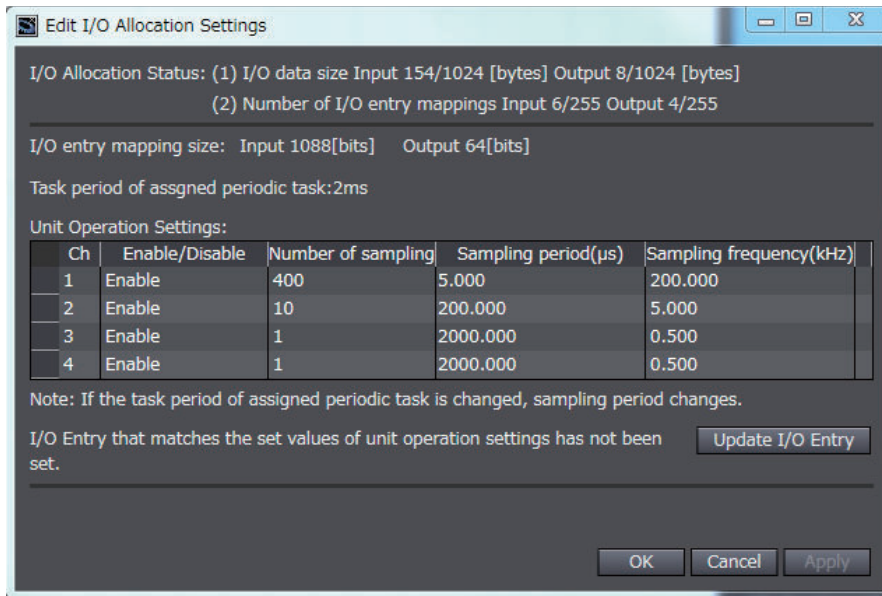

7-2-2 Displayed I/O Allocation Settings

The following I/O allocation settings are displayed.

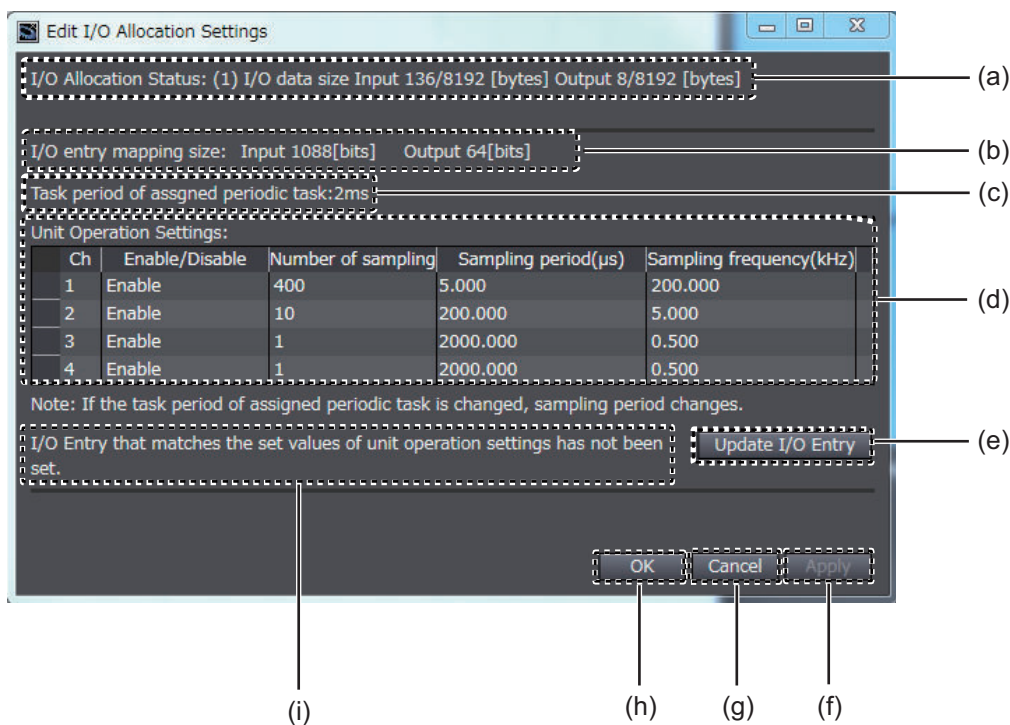

Letter	Name/Label	Description
(a)	I/O allocation status	For connection to the CPU Unit, the allocated I/O data size is displayed. For a Slave Terminal, the allocated I/O data size and the number of I/O entry mappings are displayed.
(b)	I/O entry mapping size	The I/O entry mapping size is displayed.

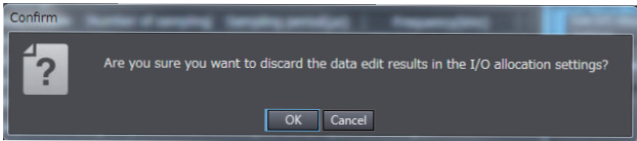
Letter	Name/Label	Description
(c)	Task period of assigned periodic tasks	The task period of assigned periodic task in the task settings is displayed.
(d)	Unit operation settings	In the Unit operation settings, the settings and set values that affect the I/O allocations are displayed. The sampling period and frequency values are also displayed.
	Ch	The analog input channel numbers are displayed.
	Enable/Disable setting	Values that you set for Ch <input type="checkbox"/> Enable/Disable in the Unit operation settings are displayed.
	Number of samplings setting	Values that you set for Ch <input type="checkbox"/> Number of Sampling Settings in the Unit operation settings are displayed. For disabled channels, - is displayed in the Ch column.
	Sampling period [μ s]	The sampling period for each channel, which is automatically calculated by the Support Software, is displayed.* ¹ For disabled channels, - is displayed in the Ch column. In addition, for channels whose sampling period is less than 5 μ s, the Ch number is displayed in red text.
	Sampling frequency [kHz]	The sampling frequency for each channel, which is automatically calculated by the Support Software, is displayed.* ² For disabled channels, - is displayed in the Ch column.
(e)	Update I/O Entry Button	Click this button to update the I/O entry to match the set values of the Unit operation settings. You can click the Update I/O Entry Button only when no I/O entry that matches the set values of the Unit operation settings has been set.
(f)	Apply Button	Click this button to enable the settings in the Edit I/O Allocation Settings Window.
(g)	Cancel Button	Click this button to return to the CPU and Expansion Racks Tab Page or Edit Slave Terminal Configuration Tab Page. If you click this button after clicking Update I/O Entry Button, the following dialog box is displayed to confirm whether to cancel the I/O allocation settings.  Click the OK Button in this dialog box to cancel the settings in the Edit I/O Allocation Settings Window, and return to the CPU and Expansion Racks Tab Page or Edit Slave Terminal Configuration Tab Page. Or click the Cancel Button to return to the Edit I/O Allocation Settings Window.
(h)	OK Button	Click this button to enable the settings in the Edit I/O Allocation Settings Window, and return to the CPU and Expansion Racks Tab Page or Edit Slave Terminal Configuration Tab Page.
(i)	Status of whether I/O entry that matches the set values of Unit operation settings has been set	This shows the status of whether an I/O entry that matches the set values of Unit operation settings has been set. If no I/O entry that matches the set values of the Unit operation settings has been set, click the Update I/O Entry Button.

*1. Refer to 8-4 *Number of Samplings Setting* on page 8-8 for the calculation formula for the sampling period.

*2. The calculation formula for the sampling frequency is as follows:

- Sampling frequency [kHz] = (1 ÷ Sampling period [μs]) × 1,000

7-2-3 Configuring the I/O Allocation Settings

The method for configuring the I/O allocation settings is given below.

- 1 Display the Edit I/O Allocation Settings Window.
For how to display the window, refer to 7-2-1 *Displaying the Edit I/O Allocation Settings Window* on page 7-14.
- 2 Click the **Update I/O Entry** Button in the Edit I/O Allocation Settings Window.

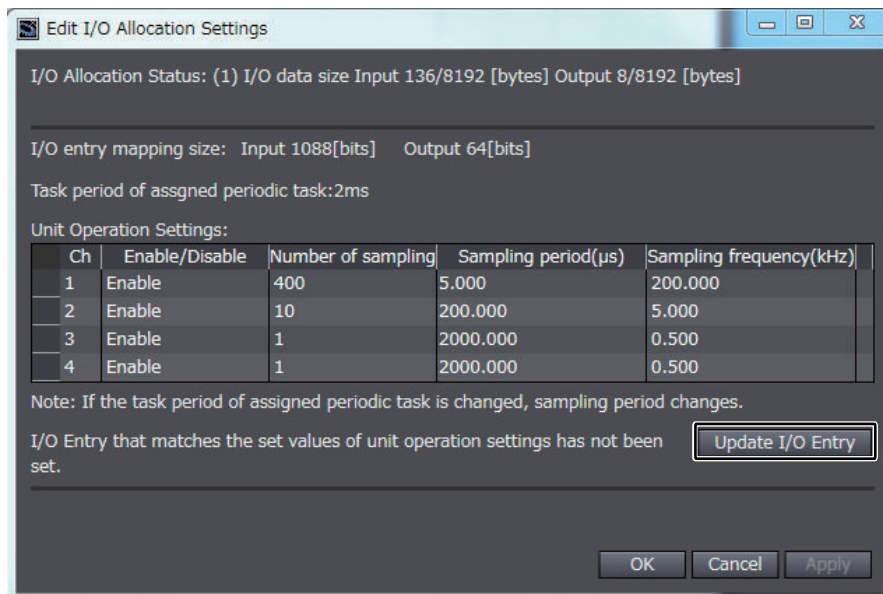

You can click the **Update I/O Entry** Button only when no I/O entry that matches the set values of the Unit operation settings has been set. When the **Update I/O Entry** Button can not be clicked, click the **Cancel** Button to close the Edit I/O Allocation Settings Window.

- 3 Click the **OK** Button in the Edit I/O Allocation Settings Window.

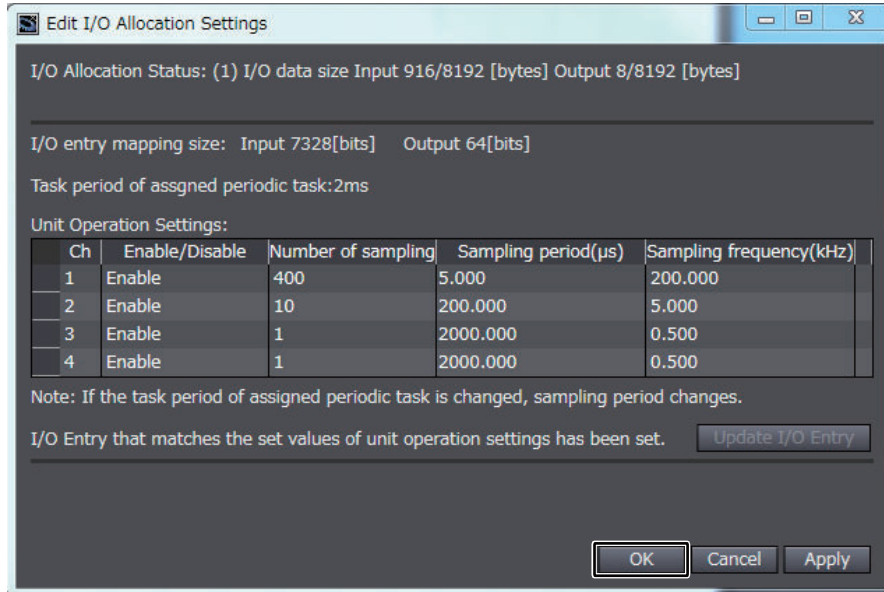

Click this button to enable the settings in the Edit I/O Allocation Settings Window, and return to the CPU and Expansion Racks Tab Page or Edit Slave Terminal Configuration Tab Page.

7-3 List of Settings

The followings are the setting descriptions, setting ranges, and default values of the functions that can be used in the High-speed Analog Input Units.

Restart the NX Unit if you change any parameter whose update timing comes after a restart of the Unit. The changed settings are reflected after the Unit restart.

It is not necessary to restart the NX Unit for parameters that are updated immediately. The settings are updated immediately after the new settings are transferred even if the NX Unit is not restarted.



Precautions for Safe Use

If you transfer parameters for Unit operation settings that are updated when the Unit is restarted after the settings are changed on the Sysmac Studio, the Unit will be restarted after the transfer is completed. Always sufficiently check the safety at the connected devices before you transfer the Unit operation settings.

Setting name	Description	Default value	Setting range	Unit	Index number (hex)	Sub-index number (hex)	Update timing	Reference
Ch1 Enable/Disable	Set to enable or disable the channel. FALSE: Disable TRUE: Enable If you change these settings, you need to set I/O allocations. Refer to <i>7-2 Setting I/O Allocations with the Sysmac Studio</i> on page 7-14 for information on how to set I/O allocations.	TRUE	TRUE or FALSE	---	5002	01	After the Unit is restarted	8-2 <i>Selecting Channel To Use</i> on page 8-4
Ch2 Enable/Disable						02		
Ch3 Enable/Disable						03		
Ch4 Enable/Disable						04		
Ch1 Range Setting	Set the analog input range.*1	0	0 to 6*1	---	5003	01	After the Unit is restarted	8-3 <i>Input Range Selection</i> on page 8-6
Ch2 Range Setting						02		
Ch3 Range Setting						03		
Ch4 Range Setting						04		

Setting name	Description	Default value	Setting range	Unit	Index number (hex)	Sub-index number (hex)	Update timing	Reference
Ch1 Disconnection Detection Enable/Disable	Set to enable or disable the disconnection detection. FALSE: Disable TRUE: Enable	FALSE	TRUE or FALSE	---	5004	01	Immediately	8-6 <i>Input Disconnection Detection</i> on page 8-29
Ch2 Disconnection Detection Enable/Disable						02		
Ch3 Disconnection Detection Enable/Disable						03		
Ch4 Disconnection Detection Enable/Disable						04		
Ch1 Number of Samplings Setting	Set the number of samplings per task period. The sampling period can be calculated as follows: • Sampling period = Task periods of assigned periodic tasks ÷ Number of samplings If you change these settings, you need to set I/O allocations. Refer to 7-2 <i>Setting I/O Allocations with the Sysmac Studio</i> on page 7-14 for information on how to set I/O allocations.	1	1, 2, 4, 5, 8, 10, 20, 25, 40, 50, 80, 100, 125, 200, 250, 400, 500, 625, or 1000*2	times	5005	01	After the Unit is restarted	8-4 <i>Number of Samplings Setting</i> on page 8-8
Ch2 Number of Samplings Setting						02		
Ch3 Number of Samplings Setting						03		
Ch4 Number of Samplings Setting						04		
Ch1 Digital Low-pass Filter Cutoff Frequency	Set the digital low-pass filter cutoff frequency for analog input signals. Set this parameter to 0 to disable the digital low-pass filter.	0	0 to 9900	× 10 Hz	5006	01	Immediately	8-5 <i>Digital Filtering</i> on page 8-18
Ch2 Digital Low-pass Filter Cutoff Frequency						02		
Ch3 Digital Low-pass Filter Cutoff Frequency						03		
Ch4 Digital Low-pass Filter Cutoff Frequency						04		

Setting name	Description	Default value	Setting range	Unit	Index number (hex)	Sub-index number (hex)	Update timing	Reference
Ch1 Filter 1 Moving Average Count	Set the moving average count for the moving average filter 1 for analog input signals. Set this parameter to 0 to disable the moving average filter 1.	0	0 to 4096	times	5007	01	Immediately	8-5 Digital Filtering on page 8-18
Ch2 Filter 1 Moving Average Count						02		
Ch3 Filter 1 Moving Average Count						03		
Ch4 Filter 1 Moving Average Count						04		
Ch1 Filter 2 Moving Average Count	Set the moving average count for the moving average filter 2 for analog input signals. Set this parameter to 0 to disable the moving average filter 2.	0	0 to 4096	times	5008	01	Immediately	8-5 Digital Filtering on page 8-18
Ch2 Filter 2 Moving Average Count						02		
Ch3 Filter 2 Moving Average Count						03		
Ch4 Filter 2 Moving Average Count						04		
Ch1 Input Filter Value Setting	Set the filter time for trigger input signals.*3	4	0, or 3 to 9*3	---	5009	01	Immediately	8-11 Input Filter on page 8-48
Ch2 Input Filter Value Setting						02		
Ch3 Input Filter Value Setting						03		
Ch4 Input Filter Value Setting						04		

*1. The meanings of the set values for **Ch□ Range Setting** are as follows.

Set value	Meaning
0	-10 to 10 V
1	-5 to 5 V
2	0 to 10 V
3	0 to 5 V
4	1 to 5 V
5	0 to 20 mA
6	4 to 20 mA

*2. The meanings of the set values for **Ch□ Number of Samplings Setting** are as follows.

Set value	Meaning
1	1 time
2	2 times
4	4 times
5	5 times
8	8 times
10	10 times
20	20 times
25	25 times
40	40 times
50	50 times
80	80 times
100	100 times
125	125 times
200	200 times
250	250 times
400	400 times
500	500 times
625	625 times
1000	1000 times

*3. The meanings of the set values for **Ch□ Input Filter Value Setting** are as follows.

Set value	Meaning
0	No filter
3	4 μ s
4	8 μ s
5	16 μ s
6	32 μ s
7	64 μ s
8	128 μ s
9	256 μ s

8

Functions

This section describes the functions of the High-speed Analog Input Units.

8-1	Function Block Diagram	8-3
8-2	Selecting Channel To Use	8-4
8-2-1	Function Applications and Overview	8-4
8-2-2	Details on the Function.....	8-4
8-2-3	Setting Method	8-5
8-3	Input Range Selection.....	8-6
8-3-1	Function Applications and Overview	8-6
8-3-2	Details on the Function.....	8-6
8-3-3	Setting Method	8-6
8-4	Number of Samplings Setting.....	8-8
8-4-1	Function Applications and Overview	8-8
8-4-2	Details on the Function.....	8-8
8-4-3	Setting Method	8-11
8-4-4	Checking the Sampling Settings	8-11
8-5	Digital Filtering	8-18
8-5-1	Function Applications and Overview	8-18
8-5-2	Details on the Function.....	8-18
8-5-3	Setting Method	8-27
8-5-4	Checking the Digital Filter Settings	8-28
8-6	Input Disconnection Detection	8-29
8-6-1	Function Applications and Overview	8-29
8-6-2	Details on the Function.....	8-29
8-6-3	Setting Method	8-30
8-7	Over Range/Under Range Detection	8-31
8-7-1	Function Applications and Overview	8-31
8-7-2	Details on the Function.....	8-31
8-7-3	Setting Method	8-32
8-8	User Calibration	8-33
8-8-1	Function Applications and Overview	8-33
8-8-2	Details on the Function.....	8-33
8-8-3	Setting Method	8-34
8-9	Zero Set/Reset	8-38
8-9-1	Function Applications and Overview	8-38
8-9-2	Details on the Function.....	8-38
8-9-3	Setting Method	8-39

8-10	Trigger Input	8-40
8-10-1	Function Applications and Overview	8-40
8-10-2	Details on the Function.....	8-40
8-10-3	Identifying the Analog Input Value When Trigger Input Was Turned ON	8-45
8-10-4	Setting Method	8-47
8-11	Input Filter	8-48
8-11-1	Function Applications and Overview	8-48
8-11-2	Details on the Function.....	8-48
8-11-3	Setting Method	8-49

8-1 Function Block Diagram

This section describes the processing order of analog input signals on the High-speed Analog Input Units.

Analog input signals are processed in the following order according to the input range and the number of samplings that you set in the Unit operation settings.

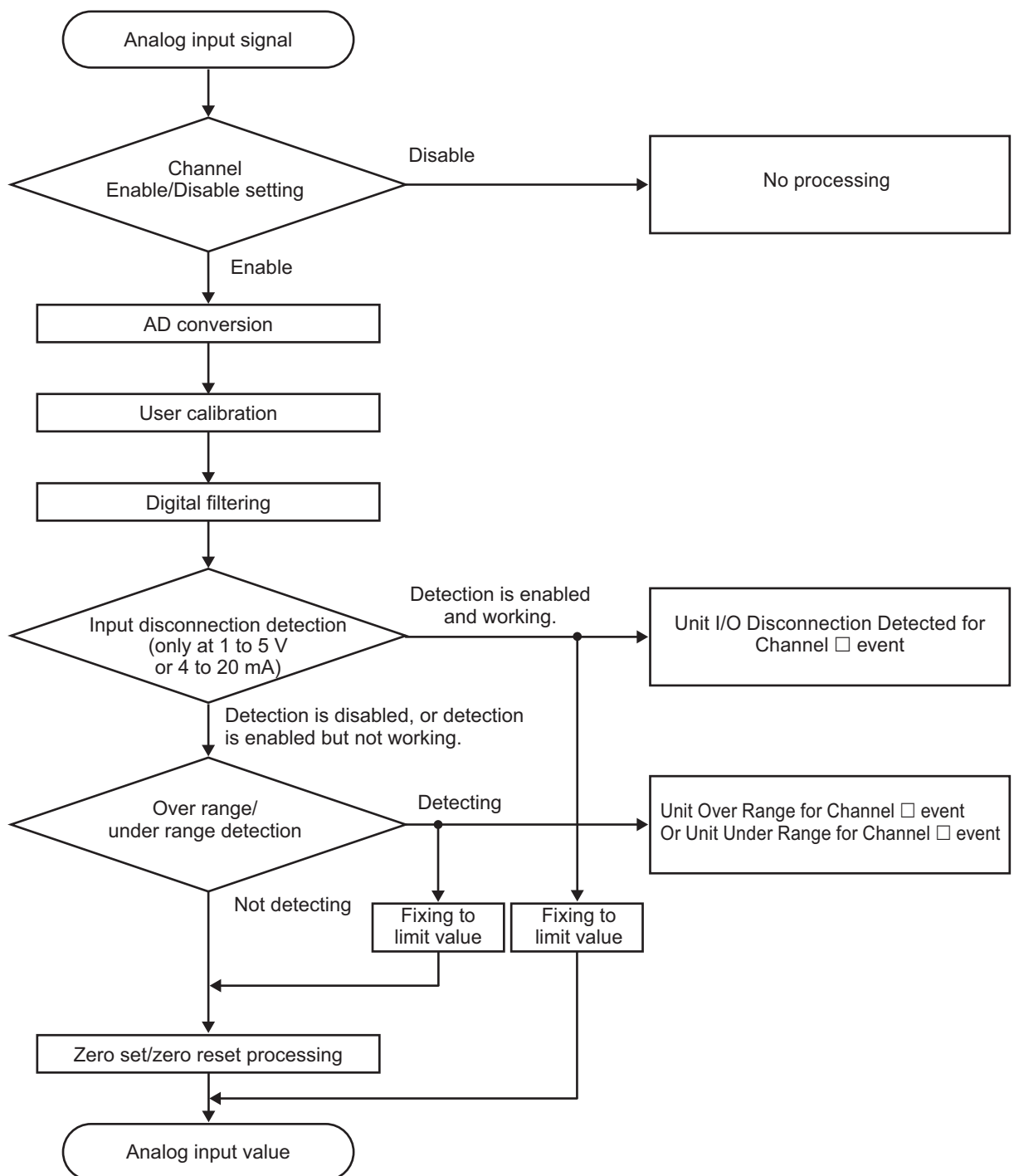

8-2 Selecting Channel To Use

8-2-1 Function Applications and Overview

This function skips the conversion processing and error detection processing for unused inputs, and reduces the size of I/O data for the Unit.

8-2-2 Details on the Function

By default, the High-speed Analog Input Units convert as many input signals as the number of inputs on them to obtain analog input data. Use this function to prevent the Units from converting input signals for unused inputs.

With this function, you can reduce the number of input signals to convert, as well as the I/O data size.

Whether the channel is enabled or disabled is settable for each input.

Set the channel enabled/disabled setting in the Unit operation settings. The settings are shown in the following table.

Setting name	Setting description	Default value	Setting range	Unit	Update timing
Ch1 Enable/Disable	Set to enable or disable the channel. FALSE: Disable TRUE: Enable	TRUE	TRUE or FALSE	---	After the Unit is re-started
Ch2 Enable/Disable					
Ch3 Enable/Disable					
Ch4 Enable/Disable					
Ch4 Enable/Disable					

Precautions for Changing the Settings

If you change the channel enabled/disabled settings, always set I/O allocations with the Sysmac Studio. Refer to 7-2 *Setting I/O Allocations with the Sysmac Studio* on page 7-14 for the setting procedure.

If no I/O entry that matches the channel enabled/disabled settings has been set, a warning icon is displayed on the following screens in the Sysmac Studio.

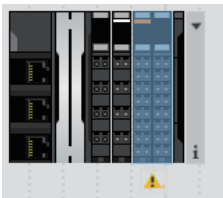
Connection made to	Screen
CPU Unit	CPU and Expansion Racks Tab Page 

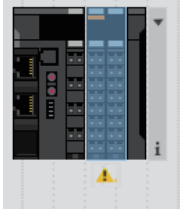
Connection made to	Screen
Communication Coupler Unit	Edit Slave Terminal Configuration Tab Page 

After completion of the settings, check with the Support Software that the following conditions are met:

- The limitations on the I/O data size are not exceeded.*¹
- No I/O Refreshing Timeout Error occurred.*²

*1. If you connect to the CPU Unit, check this on the CPU and Expansion Racks Tab Page. If you connect to the Communications Coupler Unit, check this on the Edit Slave Terminal Configuration Tab Page.

*2. Check this on the Multi-view Explorer.

8-2-3 Setting Method

This section describes how to configure settings with the Sysmac Studio.

- 1 Display the Edit Unit Operation Settings Tab Page.
For how to display the tab page, refer to *A-8 Displaying the Edit Unit Operation Settings Tab Page* on page A-54.
- 2 Select *True* (Enable) or *False* (Disable) from the list of **Input Enable/Disable Setting** for the channel (Ch□) you want to set.
Refer to *A-9 Edit Unit Operation Settings Tab Page* on page A-57 for how to edit the Unit operation settings.
- 3 Click the **Transfer to Unit** Button.
The settings are transferred from the Sysmac Studio to the NX Unit.
The settings are reflected after the Unit is restarted.



Precautions for Safe Use

If you transfer parameters for Unit operation settings that are updated when the Unit is restarted after the settings are changed on the Support Software, the Unit will be restarted after the transfer is completed. Always sufficiently check the safety at the connected devices before you transfer the Unit operation settings.

The settings are reflected after the Unit is restarted.



Precautions for Safe Use

If you transfer parameters for Unit operation settings that are updated when the Unit is restarted after the settings are changed on the Support Software, the Unit will be restarted after the transfer is completed. Always sufficiently check the safety at the connected devices before you transfer the Unit operation settings.

8-4 Number of Samplings Setting

8-4-1 Function Applications and Overview

This function sets the number of samplings of analog input data to obtain.

The sampling period is determined by the task period of the assigned periodic task and the number of samplings per period.

8-4-2 Details on the Function

The function sets the number of samplings per period for analog input data.

Here, the period means the task period of an assigned periodic task.

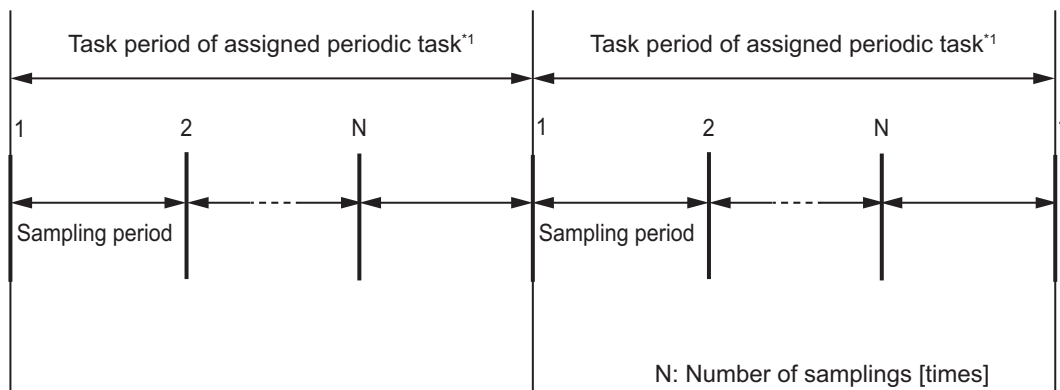

*1. The primary periodic task or the priority-5 periodic task should be assigned. If any other periodic task is assigned, the Unit does not perform sampling correctly.

The sampling period for each channel is determined by the task period of the assigned periodic task and the number of samplings per task period. The calculation formula for a Unit to which the High-speed Analog I/O Unit is connected to is as follows:

$$\text{Ch}\square \text{ Sampling Period } [\mu\text{s}] = \text{Task period of assigned periodic task } [\mu\text{s}] \div \text{Ch}\square \text{ Number of Samplings [times]}$$

For example, when the task period of an assigned periodic task is set to 1 ms and the number of samplings is set to 100, the sampling period can be calculated as follows:

- Sampling period = $1000 \mu\text{s} \div 100 \text{ times} = 10 \mu\text{s}$



Precautions for Correct Use

When you use an NX-series High-speed Analog Input Unit in the CPU Rack or Slave Terminal, the primary periodic task or the priority-5 periodic task should be assigned. If any other periodic task is assigned, the Unit does not perform sampling correctly.

Set the number of samplings in the Unit operation settings. The settings are shown in the following table.

Setting name	Setting description	Default value	Setting range	Unit	Update timing
Ch1 Number of Samplings Setting	Set the number of samplings per task period for analog input data.	1	*1	times	After the Unit is re-started
Ch2 Number of Samplings Setting					
Ch3 Number of Samplings Setting					
Ch4 Number of Samplings Setting					

*1. The meanings of the set values for **Ch□ Number of Samplings Setting** are as follows.

Set value	Meaning
1	1 time
2	2 times
4	4 times
5	5 times
8	8 times
10	10 times
20	20 times
25	25 times
40	40 times
50	50 times
80	80 times
100	100 times
125	125 times
200	200 times
250	250 times
400	400 times
500	500 times
625	625 times
1000	1000 times

Precautions for Changing the Settings

If you change the number of samplings setting, always set I/O allocations with the Sysmac Studio. Refer to *7-2 Setting I/O Allocations with the Sysmac Studio* on page 7-14 for the setting procedure. If no I/O entry that matches the number of samplings setting has been set, a warning icon is displayed on the following screens in the Sysmac Studio.

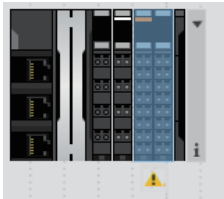
Connection made to	Screen
CPU Unit	CPU and Expansion Racks Tab Page 

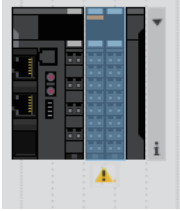
Connection made to	Screen
Communication Coupler Unit	Edit Slave Terminal Configuration Tab Page 

After completion of the settings, check with the Support Software that the following conditions are met:

- The limitations on the I/O data size are not exceeded.*1
- No I/O Refreshing Timeout Error occurred.*2

*1. If you connect to the CPU Unit, check this on the CPU and Expansion Racks Tab Page. If you connect to the Communications Coupler Unit, check this on the Edit Slave Terminal Configuration Tab Page.

*2. Check this on the Multi-view Explorer.

Examples of Possible Sampling Period Settings

The following table shows examples of sampling periods that you can set. The task periods shown below are typical values. Refer to descriptions of specifications of tasks in the software user's manual for the connected CPU Unit for information on possible task period values.

If the sampling period is indicated as "---", it is less than 5 μs and you cannot set I/O allocations.

Number of samplings [times]	Sampling period [μs]						
	Task period 125 μs *1	Task period 250 μs	Task period 500 μs	Task period 1000 μs	Task period 2000 μs	Task period 4000 μs	Task period 8000 μs
1	125	250	500	1000	2000	4000	8000
2	62.5	125	250	500	1000	2000	4000
4	31.25	62.5	125	250	500	1000	2000
5	25	50	100	200	400	800	1600
8	15.625	31.25	62.5	125	250	500	1000
10	12.5	25	50	100	200	400	800
20	6.25*2	12.5	25	50	100	200	400
25	5*2	10	20	40	80	160	320
40	---	6.25	12.5	25	50	100	200
50	---	5	10	20	40	80	160
80	---	---	6.25	12.5	25	50	100
100	---	---	5	10	20	40	80
125	---	---	---	8	16	32	64
200	---	---	---	5	10	20	40
250	---	---	---	---	8	16	32
400	---	---	---	---	5	10	20
500	---	---	---	---	---	8	16
625	---	---	---	---	---	6.4	12.8

Number of samplings [times]	Sampling period [μs]						
	Task period 125 μs *1	Task period 250 μs	Task period 500 μs	Task period 1000 μs	Task period 2000 μs	Task period 4000 μs	Task period 8000 μs
1000	---	---	---	---	---	---	8

*1. The task period 125 μs cannot be used if the Unit is connected to an NX-ECC201 or NX-ECC202 EtherCAT Coupler Unit.

*2. These settings cannot be used if the Unit is connected to an NX-ECC203 EtherCAT Coupler Unit.

Sampling Operation

Refer to *5-2-4 I/O Refreshing Operation* on page 5-9 for details on how a High-speed Analog Input Unit performs sampling.

8-4-3 Setting Method

This section describes how to configure settings with the Sysmac Studio.

- 1** Display the Edit Unit Operation Settings Tab Page.
For how to display the tab page, refer to *A-8 Displaying the Edit Unit Operation Settings Tab Page* on page A-54.
- 2** Select the number of samplings from the list of **Number of Samplings** for the channel (Ch□) you want to set.
Refer to *A-9 Edit Unit Operation Settings Tab Page* on page A-57 for how to edit the Unit operation settings.
- 3** Click the **Transfer to Unit** Button.
The settings are transferred from the Sysmac Studio to the NX Unit.
The settings are reflected after the Unit is restarted.



Precautions for Safe Use

If you transfer parameters for Unit operation settings that are updated when the Unit is restarted after the settings are changed on the Support Software, the Unit will be restarted after the transfer is completed. Always sufficiently check the safety at the connected devices before you transfer the Unit operation settings.

8-4-4 Checking the Sampling Settings

You can check the sampling settings such as the number of samplings, sampling period, and sampling frequency settings for each channel in the following windows of the Support Software:

- Edit I/O Allocation Settings Window
- Sampling Settings and Digital Filter Settings Tab Page

Refer to *7-2 Setting I/O Allocations with the Sysmac Studio* on page 7-14 for information on the Edit I/O Allocation Settings Window.

This section describes how to display the Sampling Settings and Digital Filter Settings Tab Page and information to be displayed.

Display Method

● Connected to a CPU Unit

This section describes how to display the Sampling Settings and Digital Filter Settings Tab Page for a High-speed Analog Input Unit connected to a CPU Unit.

- 1 In the Multiview Explorer, double-click the CPU Rack to which the target High-speed Analog Input Unit is connected to open the CPU and Expansion Racks Tab Page. The following tab page is displayed.

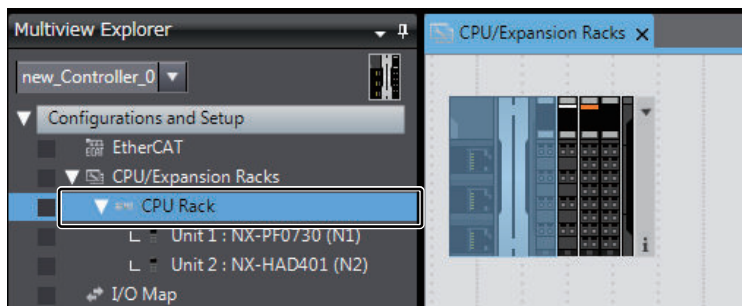

- 2 On the CPU and Expansion Racks Tab Page, right-click the High-speed Analog Input Unit and select **Sampling Settings and Digital Filter Settings** from the menu.

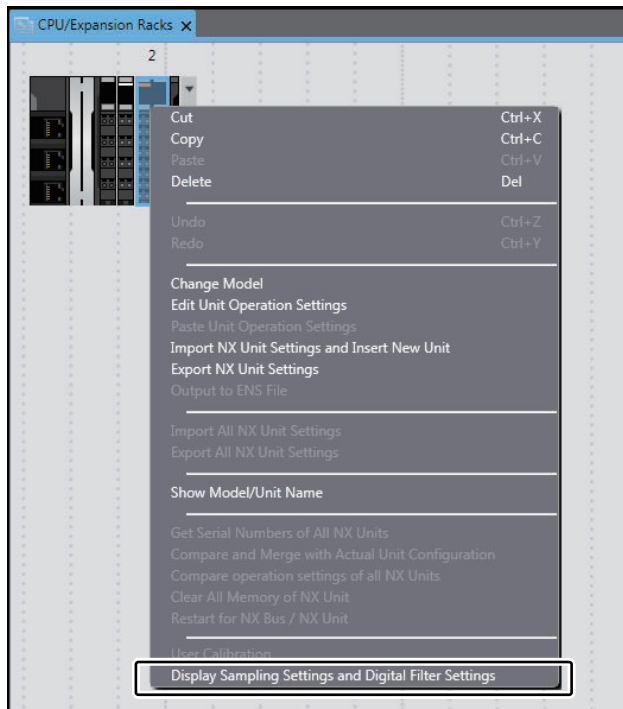

The Sampling Settings and Digital Filter Settings Tab Page is displayed.

Unit 2[NXBusMaster]:...tings (··· X)					
Task period of assigned periodic task:2ms					
	Ch1	Ch2	Ch3	Ch4	
▼ Enable/Disable settings of Ch					
Enable/Disable	Enable	Enable	Enable	Enable	
▼ Sampling settings					
Setting number of samplings (times)	400	10	1	1	
Sampling period(μs)	5.000	200.000	2000.000	2000.000	
Sampling frequency(kHz)	200.000	5.000	0.500	0.500	
▼ Digital filter settings					
▼ Digital Low-pass Filter					
Setting value of cutoff frequency (x10Hz)	500	1000	0	0	
Actual cutoff frequency (Hz)	5000	10000	-	-	
▼ Moving average filter 1					
Setting number of moving average (times)	200	4000	0	0	
Attenuation frequency (Hz)	1000.000	50.000	-	-	
▼ Moving average filter 2					
Setting number of moving average (times)	0	0	0	0	
Attenuation frequency (Hz)	-	-	-	-	
Digital filter processing period (μs)	5.000	5.000	5.000	5.000	
Digital filter processing frequency (kHz)	200.000	200.000	200.000	200.000	

● Slave Terminal

This section describes how to display the Sampling Settings and Digital Filter Settings Tab Page for a High-speed Analog Input Unit connected to a Communications Coupler Unit.

- 1 In the Multiview Explorer, double-click the Communications Coupler Unit to which the target High-speed Analog Input Unit is connected to open the Edit Slave Terminal Configuration Tab Page.

The following tab page is displayed.

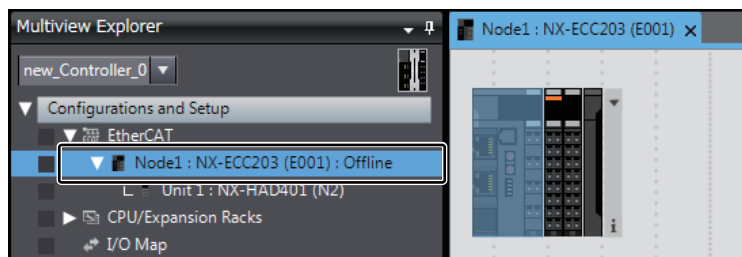

- 2 On the Edit Slave Terminal Configuration Tab Page, right-click the High-speed Analog Input Unit and select **Sampling Settings and Digital Filter Settings** from the menu.

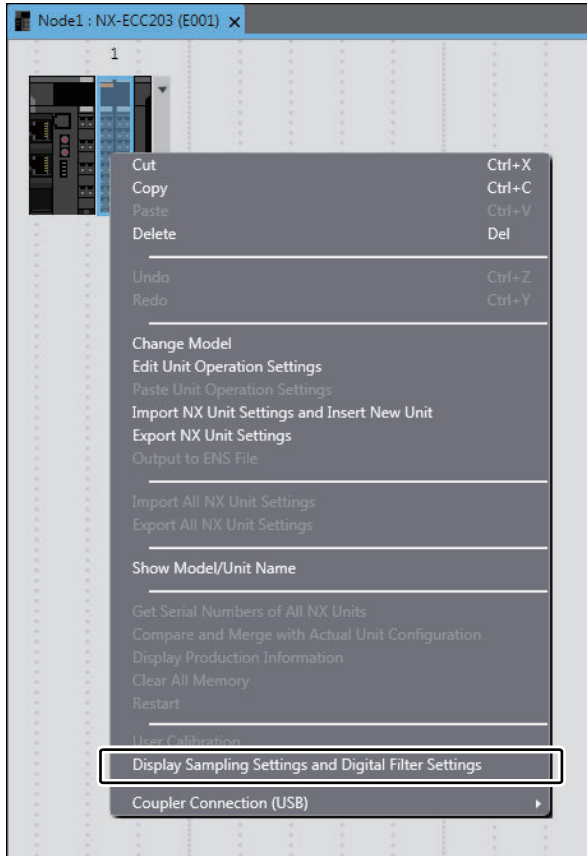

The Sampling Settings and Digital Filter Settings Tab Page is displayed.

Unit 1[Node1]: NX-HA...tings...					
Task period of assigned periodic task:2ms					
	Ch1	Ch2	Ch3	Ch4	
▼ Enable/Disable settings of Ch					
Enable/Disable	Enable	Enable	Enable	Enable	
▼ Sampling settings					
Setting number of samplings (times)	400	10	1	1	
Sampling period(μs)	5.000	200.000	2000.000	2000.000	
Sampling frequency(kHz)	200.000	5.000	0.500	0.500	
▼ Digital filter settings					
▼ Digital Low-pass Filter					
Setting value of cutoff frequency (x10Hz)	500	1000	0	0	
Actual cutoff frequency (Hz)	5000	10000	-	-	
▼ Moving average filter 1					
Setting number of moving average (times)	200	4000	0	0	
Attenuation frequency (Hz)	1000.000	50.000	-	-	
▼ Moving average filter 2					
Setting number of moving average (times)	0	0	0	0	
Attenuation frequency (Hz)	-	-	-	-	
Digital filter processing period (μs)	5.000	5.000	5.000	5.000	
Digital filter processing frequency (kHz)	200.000	200.000	200.000	200.000	

Displayed Information

The following information is displayed on the Sampling Settings and Digital Filter Settings Tab Page.

	Ch1	Ch2	Ch3	Ch4
Task period of assigned periodic task[ms]				
▼ Enable/Disable settings of Ch				
Enable/Disable	Enable	Enable	Enable	Enable
▼ Sampling settings				
Setting number of samplings (times)	400	10	1	1
Sampling period(μs)	5.000	200.000	2000.000	2000.000
Sampling frequency(kHz)	200.000	5.000	0.500	0.500
▼ Digital filter settings				
▼ Digital Low-pass Filter				
Setting value of cutoff frequency (x10Hz)	500	1000	0	0
Actual cutoff frequency (Hz)	5000	10000	-	-
▼ Moving average filter 1				
Setting number of moving average (times)	200	4000	0	0
Attenuation frequency (Hz)	1000.000	50.000	-	-
▼ Moving average filter 2				
Setting number of moving average (times)	0	0	0	0
Attenuation frequency (Hz)	-	-	-	-
Digital filter processing period (μs)	5.000	5.000	5.000	5.000
Digital filter processing frequency (kHz)	200.000	200.000	200.000	200.000

Let-ter	Name/Label	Description	
(a)	Task period of assigned periodic task	The task period of assigned periodic task in the task settings is displayed.	
(b)	Enable/Disable settings of Ch	Enable/Disable	Values that you set for Ch□ Enable/Disable in the Unit operation settings are displayed.
(c)	Sampling settings	Setting number of samplings (times)	Values that you set for Ch□ Number of Samplings Setting in the Unit operation settings are displayed. For disabled channels, - is displayed in the Ch column.
	Sampling period [μs]		The sampling period for each channel, which is automatically calculated by the Support Software, is displayed.* ¹ For disabled channels, - is displayed in the Ch column. In addition, for channels whose sampling period is less than 5 μs, the Ch number is displayed in red text.
	Sampling frequency [kHz]		The sampling frequency for each channel, which is automatically calculated by the Support Software, is displayed.* ² For disabled channels, - is displayed in the Ch column.

Letter	Name/Label		Description	
(d)	Digital filter settings	Digital low-pass filter	Setting value of cutoff frequency [$\times 10$ Hz] Actual cutoff frequency [Hz]	
			Values that you set for Ch□ Digital Low-pass Filter Cutoff Frequency in the Unit operation settings are displayed. For disabled channels, or channels whose sampling period is less than 5 μ s, - is displayed in the Ch column. The actual cutoff frequency for each channel, which is automatically calculated by the Support Software, is displayed.* ³ The digital low-pass filter of the High-speed Analog Input Unit operates at the cutoff frequency shown here. For disabled channels, channels whose sampling period is less than 5 μ s, or channels whose cutoff frequency is 0, - is displayed in the Ch column.	
	Moving average filter 1		Setting number of moving average [times]	Values that you set for Ch□ Filter 1 Moving Average Count in the Unit operation settings are displayed. For disabled channels, or channels whose sampling period is less than 5 μ s, - is displayed in the Ch column.
			Attenuation frequency [Hz]	The attenuation frequency of the moving average filter 1 for each channel, which is automatically calculated by the Support Software, is displayed.* ⁴ You can significantly attenuate the signals at this frequency and frequencies that are integer multiples of the frequency. For disabled channels, channels whose sampling period is less than 5 μ s, or channels whose moving average count is 0, - is displayed in the Ch column.
	Moving average filter 2		Setting number of moving average [times]	Values that you set for Ch□ Filter 2 Moving Average Count in the Unit operation settings are displayed. For disabled channels, or channels whose sampling period is less than 5 μ s, - is displayed in the Ch column.
			Attenuation frequency [Hz]	The attenuation frequency of the moving average filter 2 for each channel, which is automatically calculated by the Support Software, is displayed.* ⁴ You can significantly attenuate the signals at this frequency and frequencies that are integer multiples of the frequency. For disabled channels, channels whose sampling period is less than 5 μ s, or channels whose moving average count is 0, - is displayed in the Ch column.
		Digital filter processing period [μ s]	The Digital Filter Processing Period for each channel, which is automatically calculated by the Support Software, is displayed.* ⁵ For disabled channels, or channels whose sampling period is less than 5 μ s, - is displayed in the Ch column.	
		Digital filter processing frequency [kHz]	The Digital Filter Processing Frequency for each channel, which is automatically calculated by the Support Software, is displayed.* ⁵ For disabled channels, or channels whose sampling period is less than 5 μ s, - is displayed in the Ch column.	

*1. Refer to *8-4 Number of Samplings Setting* on page 8-8 for the calculation formula for the sampling period.

*2. The calculation formula for the sampling frequency is as follows:

- Sampling frequency [kHz] = $(1 \div \text{Sampling period } [\mu\text{s}]) \times 1,000$

*3. Refer to *Digital Low-pass Filter* on page 8-20 for the actual cutoff frequency.

*4. Refer to *Moving Average Filter* on page 8-23 for the attenuation frequency.

- *5. Refer to *Digital Filter Processing Period* on page 8-19 for calculation formulas for the Digital Filter Processing Period and Digital Filter Processing Frequency.

8-5 Digital Filtering

8-5-1 Function Applications and Overview

This function uses the digital filter to remove noise components that are contained in analog input signals to suppress the fluctuations of analog input values.

A digital filter can remove electrical noise that is contained in analog input signals to provide stable measurements.

8-5-2 Details on the Function

You can freely combine the following three digital filters for the High-speed Analog Input Units.

- Digital low-pass filter
- Moving average filter 1
- Moving average filter 2

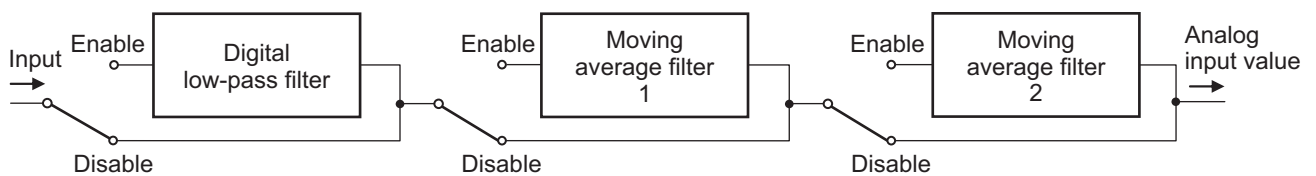

The digital low-pass filter and moving average filters are disabled by default. When the digital low-pass filter and moving average filters are used, you can set the Unit operation settings or the relevant bit in the Ch□ Operation Command of I/O data to enable the digital low-pass filter and moving average filters.

For details on digital filter functions and the procedure to enable/disable filters, refer to the following function descriptions for each digital filter.

The digital low-pass filter and moving average filters process data according to the Digital Filter Processing Period. Refer to *Digital Filter Processing Period* on page 8-19 for details on the Digital Filter Processing Period.

After digital filtering, the analog input values are stored in separate buffers for each digital filter. In the following cases, the past analog input values that are stored in buffers are cleared and the analog input values at the recovery are stored.

- When the power supply is turned ON.
- When the NX Unit is restarted.
- When the system recovers from input disconnection detection and returns to normal operation.

If the digital filter is disabled with the relevant bit in the Ch□ Operation Command, the past analog input values that are stored in the buffer for the disabled digital filter are cleared. If it is enabled, the analog input values are stored.

The High-speed Analog Input Units have a library of the Sysmac Library prepared to identify the noise frequency band and confirm the noise removal effect. Refer to *A-4 Digital Filter Design with the Library* on page A-21 for examples of digital filter design that utilizes the library.

Digital Filter Processing Period

The following describes the Digital Filter Processing Period, which is the data processing period for the digital low-pass filter and moving average filters.

● Application

The Digital Filter Processing Period is used to calculate the set value of the digital low-pass filter cutoff frequency, the set value of the moving average count for a moving average filter, and the delay time.

● Determining the Processing Period

The Digital Filter Processing Period is the period during which the High-speed Analog Input Units execute the processing of the digital low-pass filter and moving average filters in the sampling period. This period is automatically determined for each channel with the following formula. The period is calculated as a value between 5 and 9.999 μs .

$$\text{Ch}\square \text{ Digital Filter Processing Period } [\mu\text{s}] = \text{Ch}\square \text{ Sampling Period } [\mu\text{s}] \div \text{Ch}\square \text{ Number of Digital Filter Processing Operations } [\text{times}]$$

The resulting Digital Filter Processing Period is truncated to three decimal places.

The meanings of calculation elements are as follows.

Element	Description
Ch□ Sampling Period	This indicates the sampling period of analog input data during the task period in the relevant channel. Refer to <i>8-4 Number of Samplings Setting</i> on page 8-8 for the calculation formula for the sampling period.
Ch□ Number of Digital Filter Processing Operations	This indicates the number of processing operations during the sampling period in the relevant channel. It can be calculated with the following formula. <ul style="list-style-type: none"> Ch□ Number of Digital Filter Processing Operations [times] = Ch□ Sampling Period [μs] \div 5 μs <p>The Ch□ Number of Digital Filter Processing Operations is calculated as an integer. The decimal portion of the result is truncated.</p>

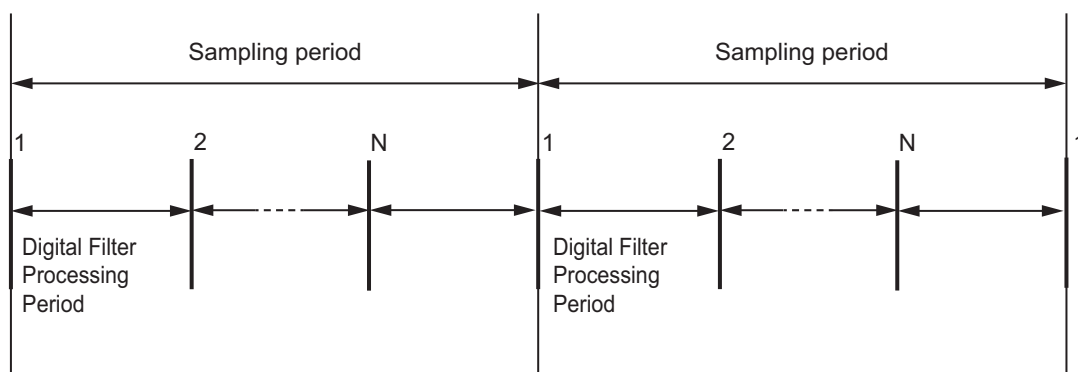

N [times]: Number of digital filter processing operations [times]



Additional Information

The digital filter processing frequency can be calculated as follows:

- Ch□ Digital Filter Processing Frequency [kHz] = $(1 \div \text{Ch□ Digital Filter Processing Period} [\mu\text{s}]) \times 1,000$

● How to Check the Processing Period

You can check the Digital Filter Processing Period value on the Sampling Settings and Digital Filter Settings Tab Page of the Support Software. Refer to *8-5-4 Checking the Digital Filter Settings* on page 8-28 for details on the Sampling Settings and Digital Filter Settings Tab Page.

● Calculation Examples for the Digital Filter Processing Period

Calculation Example 1

When the task period of an assigned periodic task is set to 1 ms and the number of samplings is set to 100, the sampling period is 10 μs . At this time, the Number of Digital Filter Processing Operations is as follows:

- Ch□ Number of Digital Filter Processing Operations = $10 \mu\text{s} \div 5 \mu\text{s} = 2$ times

Hence, the Digital Filter Processing Period is as follows:

- Ch□ Digital Filter Processing Period = $10 \mu\text{s} \div 2 \text{ times} = 5 \mu\text{s}$

Calculation Example 2

When the task period of an assigned periodic task is set to 125 μs and the number of samplings is set to 10, the sampling period is 12.5 μs .

At this time, the Number of Digital Filter Processing Operations is as follows:

- Ch□ Number of Digital Filter Processing Operations = $12.5 \mu\text{s} \div 5 \mu\text{s} = 2$ times

Hence, the Digital Filter Processing Period is as follows:

- Ch□ Digital Filter Processing Period = $12.5 \mu\text{s} \div 2 \text{ times} = 6.25 \mu\text{s}$

Digital Low-pass Filter

The digital low-pass filter attenuates input signals by -3 dB with the set cutoff frequency.

● Cutoff Frequency Setting

Set the cutoff frequency in the Unit operation settings. The settings are shown in the following table.

Setting name	Setting description	Default value	Setting range	Unit	Update timing	Remarks
Ch1 Digital Low-pass Filter Cutoff Frequency	Set the digital low-pass filter cutoff frequency.	0	0 to 9900* ¹	× 10 Hz	Immediately	Set this parameter to 0 to disable the digital low-pass filter.
Ch2 Digital Low-pass Filter Cutoff Frequency						
Ch3 Digital Low-pass Filter Cutoff Frequency						
Ch4 Digital Low-pass Filter Cutoff Frequency						

*1. The cutoff frequency must be set based on the Digital Filter Processing Period settings. Refer to *Restrictions for Cutoff Frequency Setting* on page 8-21 for the setting restrictions.

● Restrictions for Cutoff Frequency Setting

Set the cutoff frequency in the following range:

$$0 < \text{Set value of cutoff frequency} \leq (((1 \div \text{Digital Filter Processing Period} [\mu\text{s}]) \times 1,000,000) \times 0.495) \div 10 \text{ Hz}$$

If the value exceeds the upper limit, it is set to the upper limit.

For example, when the Digital Filter Processing Period is set to 6.25 μs , the cutoff frequency must be set in the following range:

$$0 < \text{Set value of cutoff frequency} \leq (((1 \div 6.25 \mu\text{s}) \times 1,000,000) \times 0.495) \div 10 \text{ Hz} = 7,920$$

● Precautions When You Change Set Values

If you use the actual system to adjust the values of settings that are designed to be updated immediately after a change, change the values of only those settings and transfer them to the Unit. Note that you need to restart the Unit if you change and transfer the values of settings that are designed to be updated only after a restart.

● Digital Low-pass Filter Enable/Disable Setting

The digital low-pass filter is disabled by default.

Set the cutoff frequency in the Unit operation settings to a value other than 0 to enable the digital low-pass filter.

Set the cutoff frequency in the Unit operation settings to 0 to disable the digital low-pass filter.

You can enable/disable the digital low-pass filter with the relevant bit in the Ch□ Operation Command of I/O data.

To enable/disable the digital low-pass filter with the relevant bit, set the cutoff frequency in the Unit operation settings to a value other than 0. If the cutoff frequency is set to 0, the digital low-pass filter will not be enabled even if the relevant bit is set to enable.

The relevant bit is Ch□ Digital Low-pass Filter Disable. Refer to *Ch□ Operation Command* on page 7-11 for details on Ch□ Operation Command.

● Attenuation Characteristics and Step Response Characteristics

a. Attenuation characteristics

The attenuation characteristics of the digital low-pass filter for typical cutoff frequencies are shown below.

Input signals are attenuated by -3 dB with the cutoff frequency. Note that the attenuation characteristics shown in these graphs are based on theoretical values.

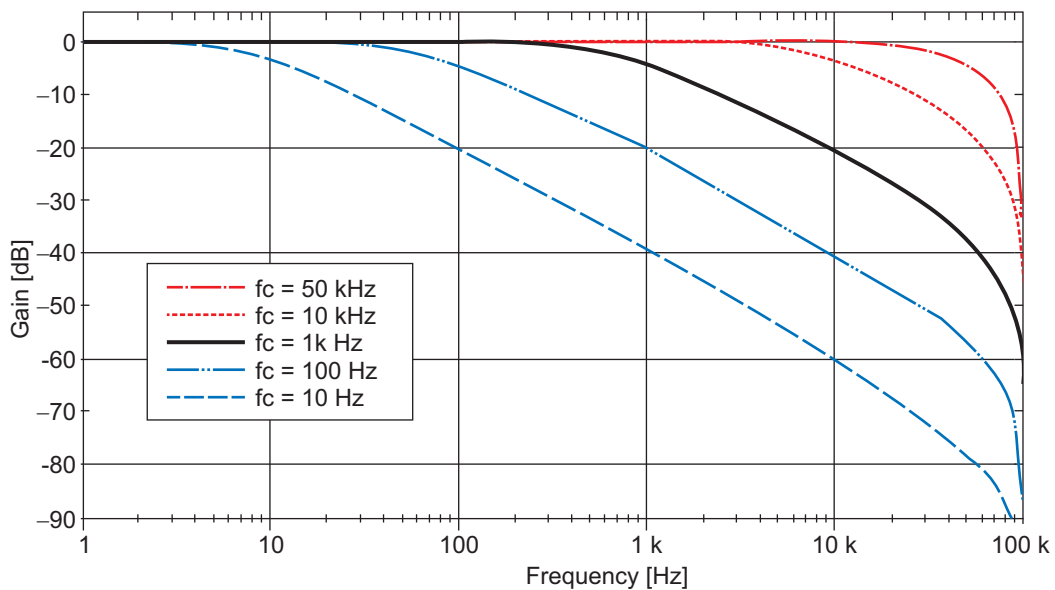

b. Step response characteristics

The step response characteristics of the digital low-pass filter with the cutoff frequency set to 1 kHz are shown below. The step response time of the digital low-pass filter is 366.4 μ s if the cutoff frequency is set to 1 kHz. The step response time is the time until the output of the digital filter reaches 90% from 0% when the step signal is input to the digital low-pass filter.

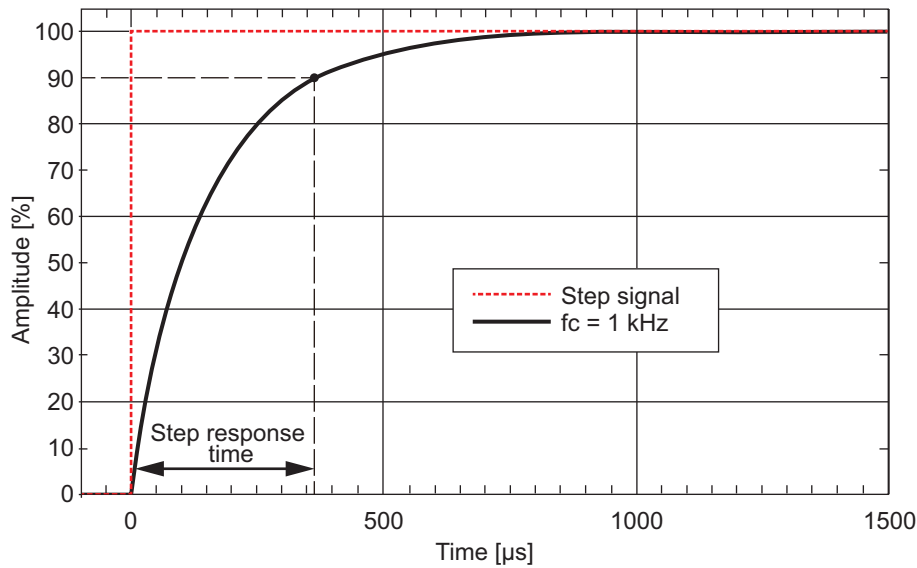

The step response times for typical cutoff frequencies are shown below.

Cutoff frequency [Hz]	Step response time [μs]
10	36,646.8
100	3,664.7
1 k	366.4
10 k	36.2
50 k	4.5

The smaller the cutoff frequency is, the wider range of noise you can remove. This stabilizes the analog input values, but causes the step response time to increase. When you use the digital low-pass filter, the analog input values are measured with a delay in response to the input as shown in the step response characteristics. When the NX bus I/O refreshing is executed in the middle of digital low-pass filtering, the analog input values in the middle of digital low-pass filtering are sent to the CPU Unit or communications master. Set the cutoff frequency that is most suitable for the measurement.

Moving Average Filter

This function calculates the average of the input signals for the set moving average count and uses it as the analog input value.

You can use the moving average filter to significantly attenuate the signals in the specific frequency and the frequencies that are integer multiples of that frequency.

To attenuate two frequencies, combine the moving average filter 1 and moving average filter 2.

● Description of Operation

The moving average processing of the Unit is shown below using the moving average count of 4 as an example.

The High-speed Analog Input Units convert input signals based on the Digital Filter Processing Period. Converted analog input data is stored in moving average buffers to perform the moving average processing. If the moving average count is not reached, the analog input data stored in the buffers is processed as moving average data. The moving average data is output as an analog input value at the timing of sampling.

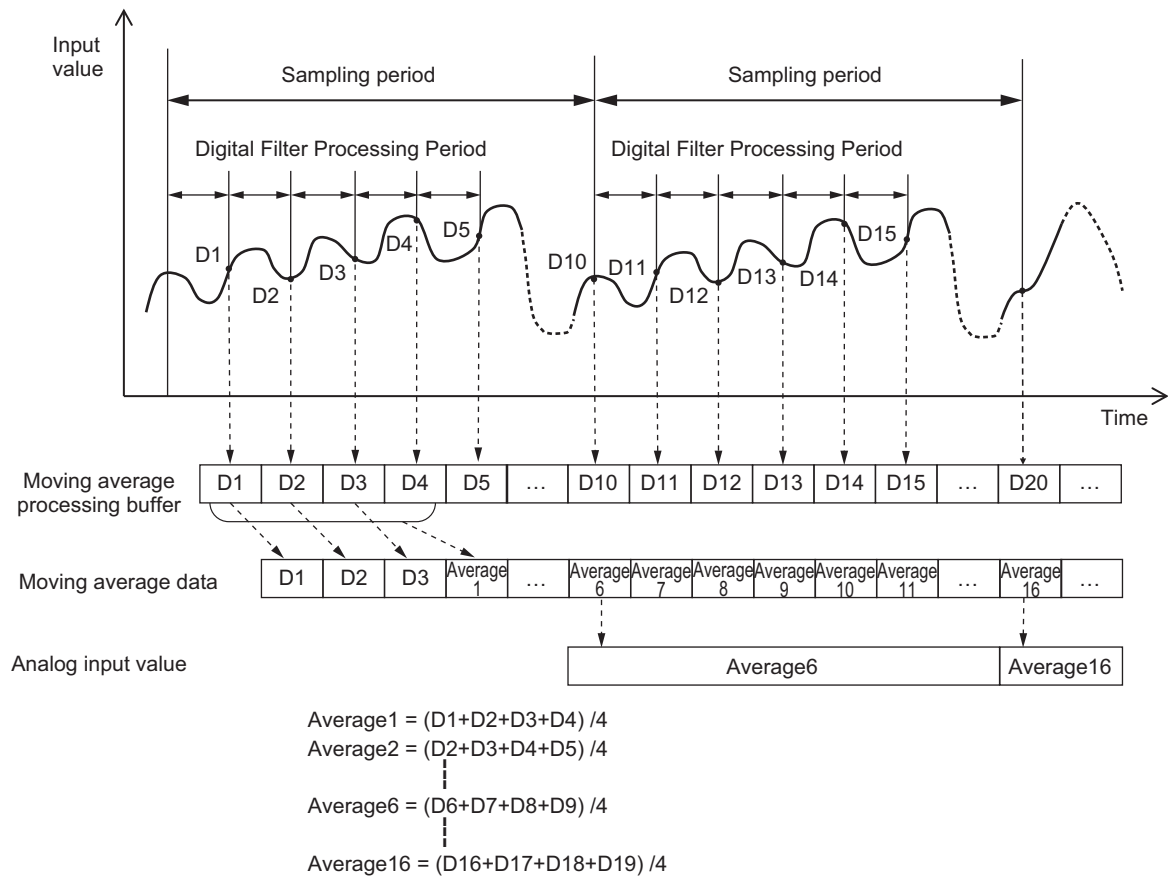

● Moving Average Count Setting

Set the moving average count in the Unit operation settings. The settings are shown in the following table.

Setting name	Setting description	Default value	Setting range	Unit	Update timing	Remarks
Ch1 Filter 1 Moving Average Count	Set the moving average count for the moving average filter 1.	0	0 to 4096	times	Immediately	Set this parameter to 0 to disable the moving average filter.
Ch2 Filter 1 Moving Average Count						
Ch3 Filter 1 Moving Average Count						
Ch4 Filter 1 Moving Average Count						
Ch1 Filter 2 Moving Average Count	Set the moving average count for the moving average filter 2.	0	0 to 4096	times		
Ch2 Filter 2 Moving Average Count						
Ch3 Filter 2 Moving Average Count						
Ch4 Filter 2 Moving Average Count						

● Precautions When You Change Set Values

If you use the actual system to adjust the values of settings that are designed to be updated immediately after a change, change the values of only those settings and transfer them to the Unit. Note that you need to restart the Unit if you change and transfer the values of settings that are designed to be updated only after a restart.

● Moving Average Filter Enable/Disable Setting

The moving average filters are disabled by default.

Set the moving average count for the filter to enable in the Unit operation settings to a value other than 0 to enable the moving average filter.

Set the moving average count for the filter to disable in the Unit operation settings to 0 to disable the moving average filter.

You can also enable/disable the moving average filter with the relevant bit in the Ch□ Operation Command of I/O data. To enable/disable the moving average filter with the relevant bit, set the moving average count for the filter to enable in the Unit operation settings to a value other than 0. If the moving average is set to 0, the moving average filter will not be enabled even if the relevant bit is set to enable. The relevant bit is Ch□ Moving Average Filter 1 Disable or Ch□ Moving Average Filter 2 Disable.

Refer to *Ch□ Operation Command* on page 7-11 for details on Ch□ Operation Command.

● Attenuation Characteristics and Step Response Characteristics

a. Attenuation characteristics

You can use the moving average filter to significantly attenuate the signals in the specific frequency and the frequencies that are integer multiples of that frequency.

The following calculation formula shows the relationship between the frequency f_N and the set value of the moving average count.

$$\text{Set value of moving average count} = \frac{(1 \div \text{Digital Filter Processing Period } [\mu\text{s}]) \times 1,000,000 \text{ [Hz]}}{f_N \text{ [Hz]}}$$

For example, to improve the attenuation effect by 1 kHz when the Digital Filter Processing Period is 5 μs , the set value of the moving average count can be calculated as follows:

$$\text{Set value of moving average count} = ((1 \div 5 \mu\text{s}) \times 1,000,000) \div 1,000 \text{ Hz} = 200 \text{ times}$$

Refer to *Digital Filter Processing Period* on page 8-19 for information on the Digital Filter Processing Period.

Set the moving average count based on the above formula.

The figure below shows an example of attenuation characteristics in the following case: only the moving average filter 1 is used, the moving average count is set to 200 times, and the Digital Filter Processing Period is 5 μs .

As shown in the attenuation characteristics below, you can significantly attenuate the signals in the frequencies of 1 kHz and the frequencies that are integer multiples of 1 kHz. Note that the attenuation characteristics shown in these graphs are based on theoretical values.

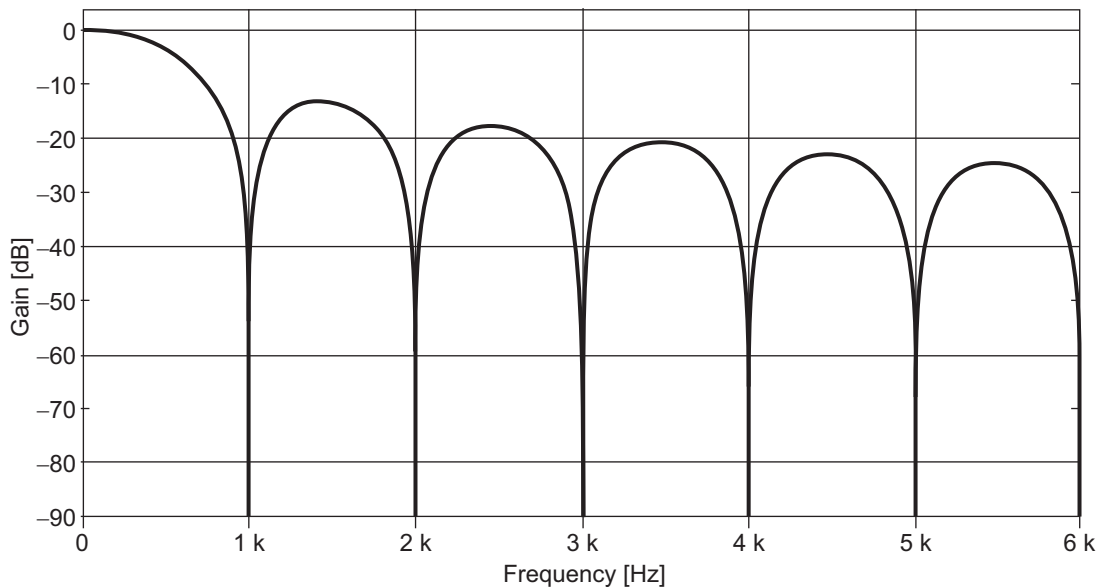

b. Step response characteristics

The figure below shows step response characteristics in the following case: only the moving average filter 1 is used, the moving average count is set to 200 times, and the Digital Filter Processing Period is 5 μs . The delay time of the moving average filter when the moving average count is set to 200 times is 995 μs . The delay time is the time until the output of the moving

average filter reaches 100% from 0% when the step signal is input for one moving average filter.

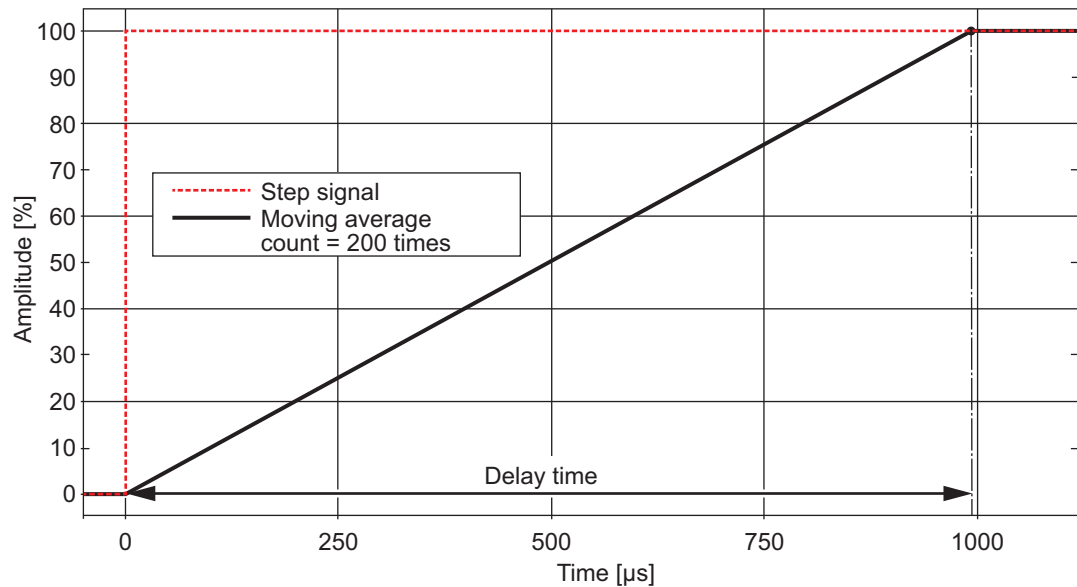

You can calculate the delay time shown for the step response characteristics using the calculation formula below. However, the value for the moving average count using the calculation formula below is 1 or higher.

$$\text{Delay time } [\mu\text{s}] = (\text{Moving average count} - 1) \times \text{Digital Filter Processing Period } [\mu\text{s}]$$

The larger the moving average count, the wider range of noise you can remove. This stabilizes the analog input values, but causes the delay time to increase. When you use the moving average filter, the analog input values are measured with a delay in response to the input as shown in the step response characteristics. When the NX bus I/O refreshing is executed in the middle of digital low-pass filtering, the analog input values in the middle of digital low-pass filtering are sent to the CPU Unit or communications master. Set the moving average count that is most suitable for the measurement.

8-5-3 Setting Method

This section describes how to configure settings with the Sysmac Studio.

- 1** Display the Edit Unit Operation Settings Tab Page.
For how to display the tab page, refer to *A-8 Displaying the Edit Unit Operation Settings Tab Page* on page A-54.
- 2** Enter the set values in the **Digital Low-pass Filter Cutoff Frequency**, **Filter 1 Moving Average Count**, and **Filter 2 Moving Average Count** for the channel (Ch□) you want to set. Refer to *A-9 Edit Unit Operation Settings Tab Page* on page A-57 for how to edit the Unit operation settings.
- 3** Click the **Transfer to Unit** Button.
The settings are transferred from the Sysmac Studio to the NX Unit.

The settings are reflected immediately.

8-5-4 Checking the Digital Filter Settings

You can check the digital filter settings on the Sampling Settings and Digital Filter Settings Tab Page of the Support Software.

Refer to *Display Method* on page 8-12 for how to display the Sampling Settings and Digital Filter Settings Tab Page and *Displayed Information* on page 8-14 for the displayed information.

8-6 Input Disconnection Detection

8-6-1 Function Applications and Overview

This function detects disconnections of the analog input signal lines.

However, it detects disconnections only when the input range is 1 to 5 V or 4 to 20 mA.

8-6-2 Details on the Function

- The line disconnection detection function is disabled by default to prevent it from working when the Unit is not wired, for example, while the system is being prepared for a start-up. To use the line disconnection detection, enable the disconnection detection.
- If the disconnection detection function and the selecting channel to use function are both enabled for an input channel, the input signal is converted to 32767 when the relevant analog input signal line is disconnected or when either of the following conditions is met for the input.

Item	Analog input value
Input voltage	Less than 0.3 V
Input current	Less than 1.2 mA

At this time, the Ch□ Disconnection Detection Status bit in the Ch□ Status of I/O data turns ON and a Unit I/O Disconnection Detected for Ch□ event occurs.

- If the input returns to the conversion range again, the value becomes a normal converted value. When the cause of the error is removed and the error is reset, the Ch□ Disconnection Detection Status bit of the Ch□ Status of I/O data turns OFF.
- Refer to 7-1 *Specifications of I/O Data* on page 7-2 for details on I/O data. Refer to 9-3-3 *Event Codes and Corrections for Errors* on page 9-6 for details on events.

You can enable or disable the disconnection detection in the Unit operation settings. The settings are shown in the following table.

Setting name	Setting description	Default value	Setting range	Unit	Update timing
Ch1 Disconnection Detection Enable/Disable	Set to enable or disable the disconnection detection. FALSE: Disable TRUE: Enable	FALSE	TRUE or FALSE	---	Immediately
Ch2 Disconnection Detection Enable/Disable					
Ch3 Disconnection Detection Enable/Disable					
Ch4 Disconnection Detection Enable/Disable					

● Precautions When You Change Set Values

If you use the actual system to adjust the values of settings that are designed to be updated immediately after a change, change the values of only those settings and transfer them to the Unit. Note that you need to restart the Unit if you change and transfer the values of settings that are designed to be updated only after a restart.

8-6-3 Setting Method

This section describes how to configure settings with the Sysmac Studio.

- 1** Display the Edit Unit Operation Settings Tab Page.
For how to display the tab page, refer to *A-8 Displaying the Edit Unit Operation Settings Tab Page* on page A-54.
- 2** Select *True* (Enable) or *False* (Disable) from the list of **Disconnection Detection Enable/Disable** for the channel (Ch□) you want to set.
Refer to *A-9 Edit Unit Operation Settings Tab Page* on page A-57 for how to edit the Unit operation settings.
- 3** Click the **Transfer to Unit** Button.
The settings are transferred from the Sysmac Studio to the NX Unit.
The settings are reflected immediately.

8-7 Over Range/Under Range Detection

8-7-1 Function Applications and Overview

This function detects when the analog input signal exceeds the range for which conversion is possible.

8-7-2 Details on the Function

The operations of the over range/under range detection are described below.

- If the input signal exceeds the upper limit of the input conversion range, the converted value is fixed at the upper limit. If this state continues for 100 ms, the Ch□ Over Range bit in the Ch□ Status of I/O data turns ON and a Unit Over Range for Ch□ event occurs. (Refer to (a) in the figure below.)
- If the input signal falls below the lower limit of the input conversion range, the converted value is fixed at the lower limit. If this state continues for 100 ms, the Ch□ Under Range bit in the Ch□ Status of I/O data turns ON and a Unit Under Range for Ch□ event occurs. (Refer to (b) in the figure below.)
- When the input signal returns to the input conversion range, the fixing is canceled and the values become the converted values.

When the cause of the error is removed and the error is reset, the Ch□ Over Range and Ch□ Under Range bits of the Ch□ Status of I/O data turn OFF. (Refer to (c) in the figure below.)

- Refer to 7-1 *Specifications of I/O Data* on page 7-2 for details on I/O data. Refer to 9-3-3 *Event Codes and Corrections for Errors* on page 9-6 for details on events.

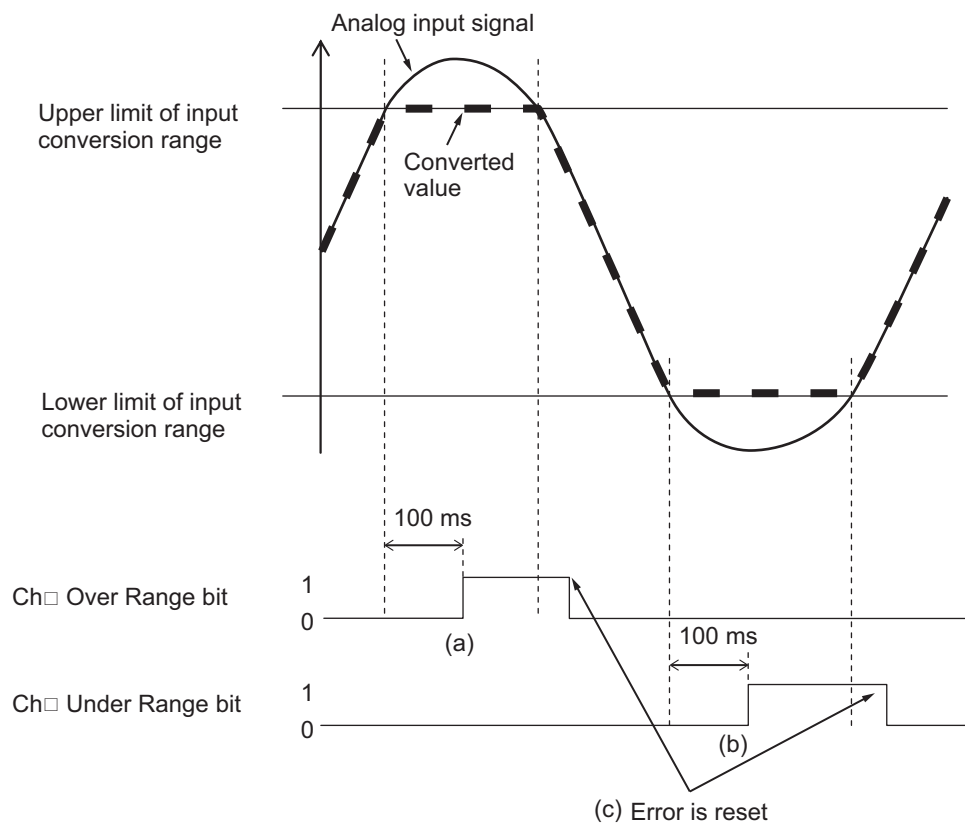

8-7-3 Setting Method

No setting is required.

8-8 User Calibration

8-8-1 Function Applications and Overview

This function corrects offsets in the converted values that occur due to the deterioration of the High-speed Analog Input Units, and calibrates the Units again.

You can use this function to calibrate the equipment that requires the periodic calibration.

8-8-2 Details on the Function

This function corrects the converted values of input voltages and input currents at 2 points, 0% and 100%, as shown in the figure below.

The calibration result is saved in the High-speed Analog Input Units.

● Calibration Example 1

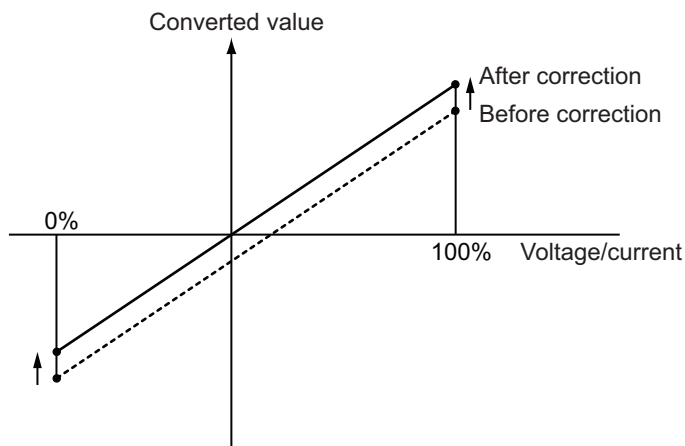

● Calibration Example 2

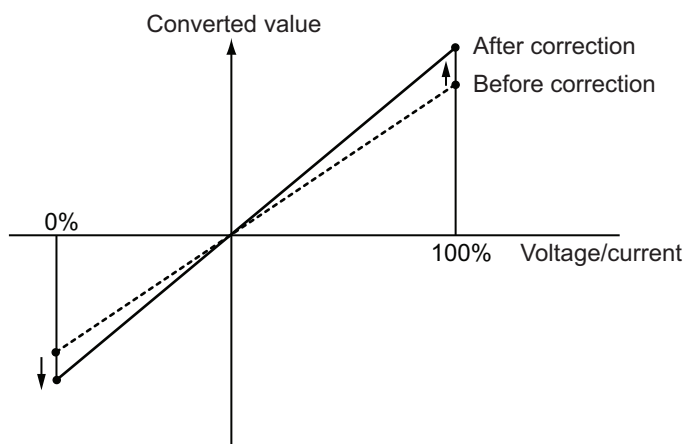

● Correctable Range

If the input range is -10 to 10 V or -5 to 5 V, the correctable range is -1% to 1% of the input full scale. For other input range settings, the correctable range is -2% to 2% of the input full scale.

The correctable range for each input range is as follows.

Input range	Correctable range	
	0%	100%
-10 to 10 V	-10.2 to -9.8 V	9.8 to 10.2 V
-5 to 5 V	-5.1 to -4.9 V	4.9 to 5.1 V
0 to 10 V	-0.2 to 0.2 V	9.8 to 10.2 V
0 to 5 V	-0.1 to 0.1 V	4.9 to 5.1 V
1 to 5 V	0.92 to 1.08 V	4.92 to 5.08 V
0 to 20 mA	-0.4 to 0.4 mA	19.6 to 20.4 mA
4 to 20 mA	3.68 to 4.32 mA	19.68 to 20.32 mA

8-8-3 Setting Method

This section describes how to configure settings with the Sysmac Studio.

It also describes the procedure to reset the calibration value to the default, along with the calibration method.

Calibration Method

- 1 Display the User Calibration Window.
For the display methods, refer to *A-10 Displaying the User Calibration Window* on page A-59.
- 2 Select the channel you want to calibrate from **Channel**.

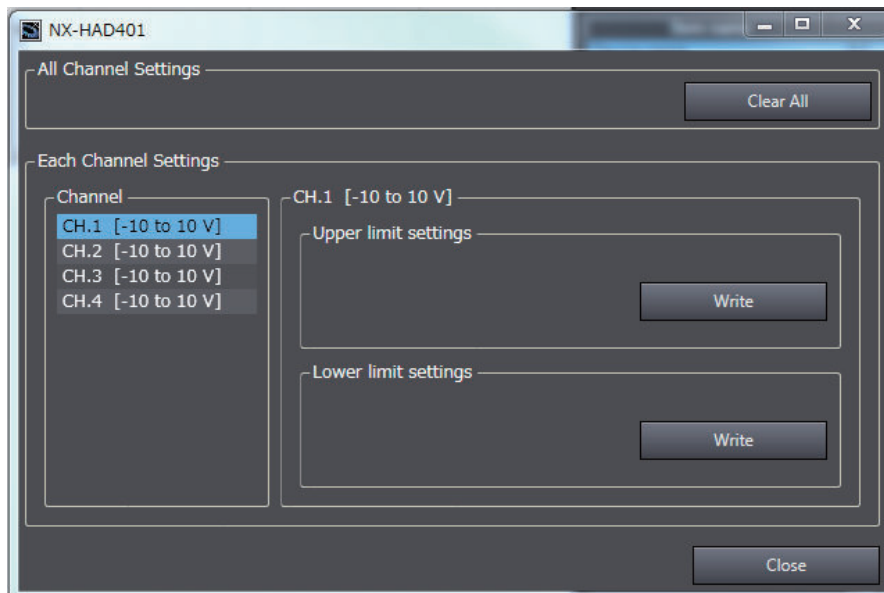

- 3 Enter the voltage or current corresponding to upper limit (100%) to the Unit terminal, then click the **Write** Button under **Upper limit settings**.

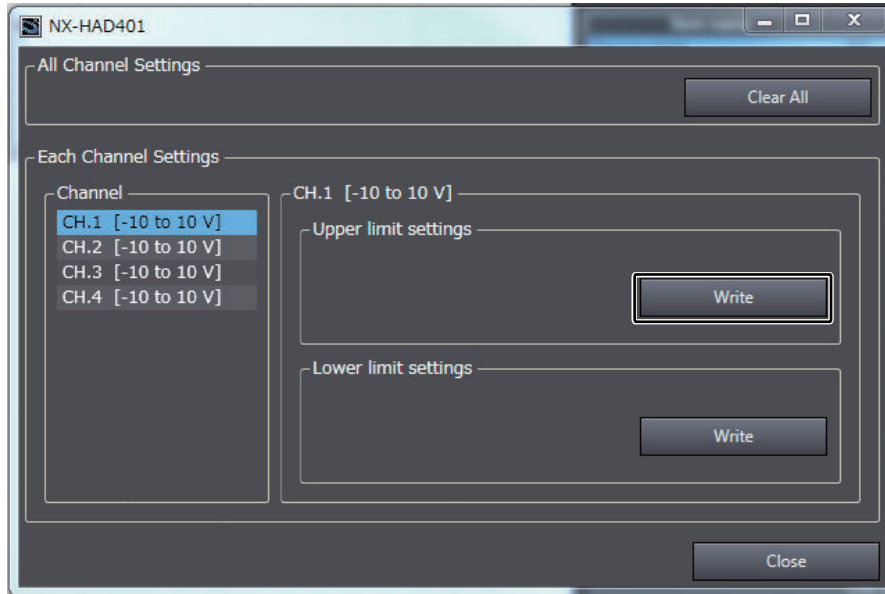

An execution confirmation dialog box is displayed.

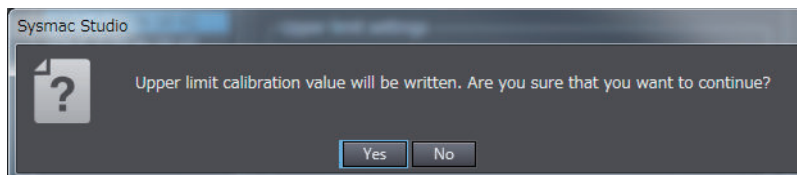

- 4** Click the **Yes** Button. When the writing is completed successfully, the following dialog box is displayed. Click the **OK** Button.

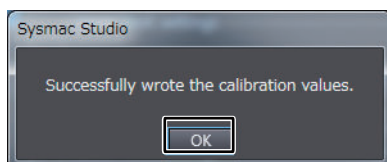

- 5** Enter the voltage or current corresponding to lower limit (0%) to the Unit terminal, then click the **Write** Button under **Lower limit settings**.

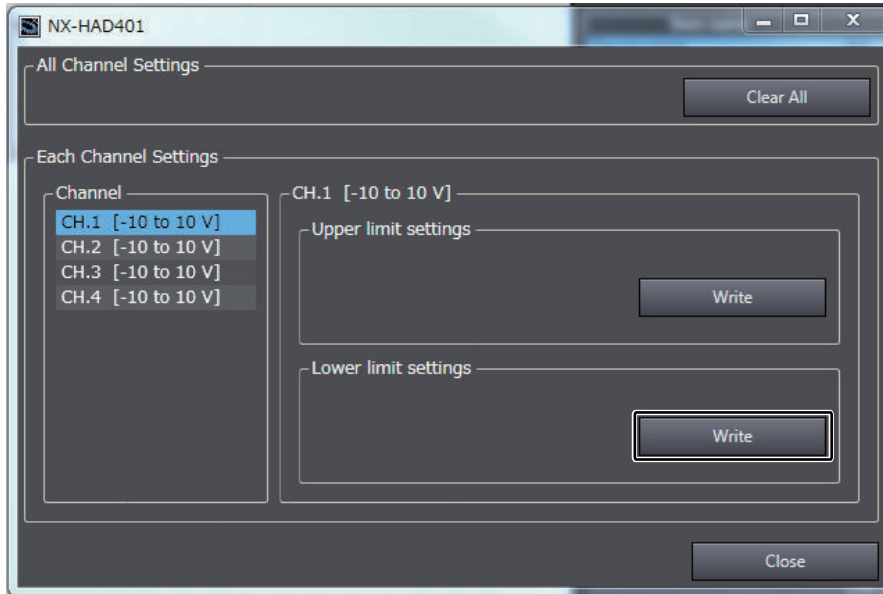

An execution confirmation dialog box is displayed.

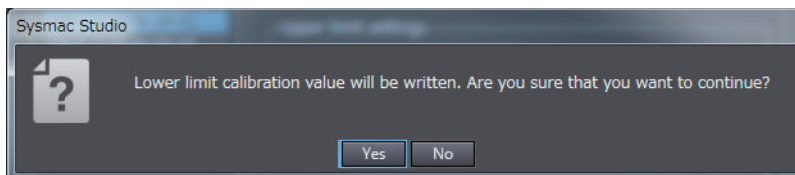

- 6** Click the **Yes** Button. When the writing is completed successfully, the following dialog box is displayed. Click the **OK** Button.

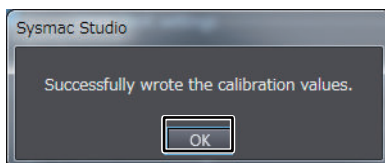

Additional Information

- A new calibration value is reflected immediately after you write it.
- When you write a calibration value, if the voltage or current that is input to the Unit terminal is outside the correctable range, a dialog box as shown below will be displayed and calibration will fail.

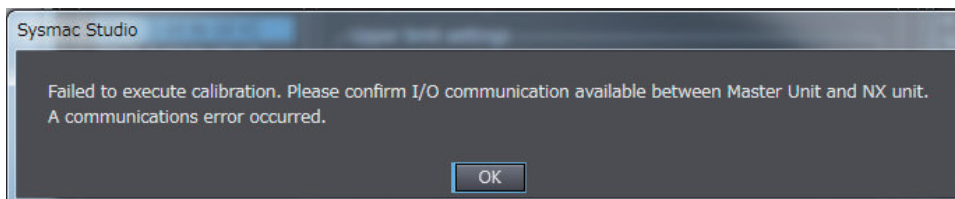

Resetting the Calibration Value to the Default

This section describes how to reset the calibration value to the default.

- 1 Display the User Calibration Window.
For the display methods, refer to *A-10 Displaying the User Calibration Window* on page A-59.
- 2 Click the **Clear All** Button under **All Channel Settings**.

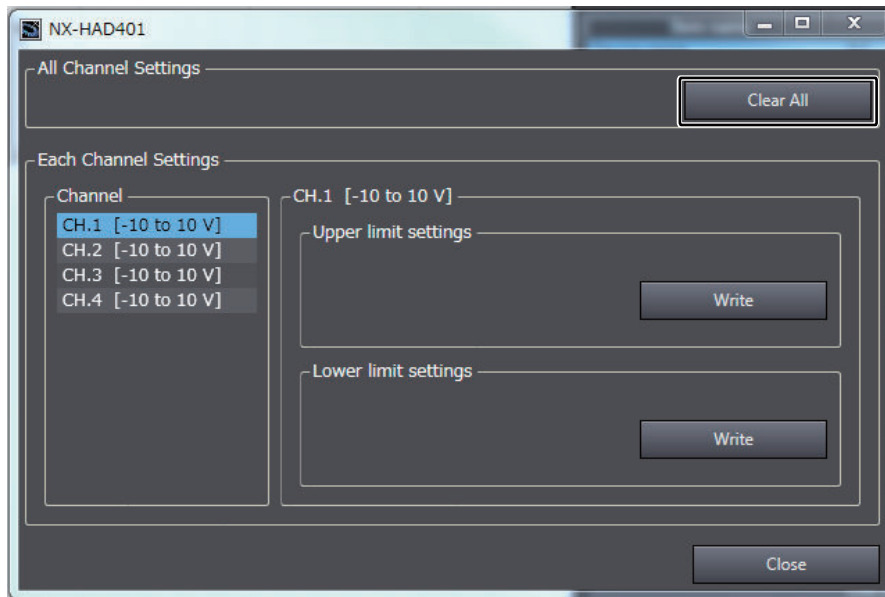

An execution confirmation dialog box is displayed.

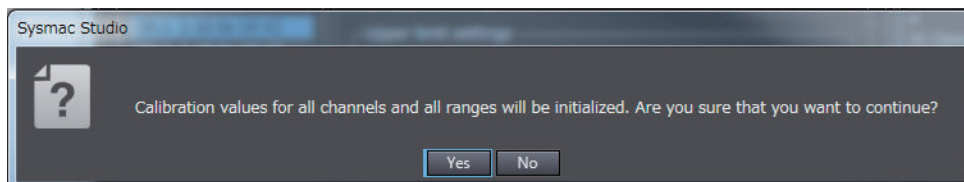

- 3 Click the **Yes** Button. When the writing is completed successfully, the following dialog box is displayed. Click the **OK** Button.

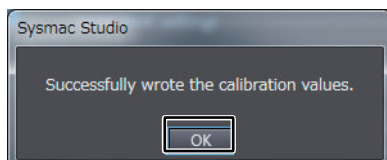

8-9 Zero Set/Reset

8-9-1 Function Applications and Overview

The zero set function corrects the analog input value to be the zero point at a desired time. The zero reset function resets the correction that is performed with the zero set function. Use these functions to correct the zero points of analog input signals.

8-9-2 Details on the Function

When the zero set is executed, the analog input value at the point of execution is corrected to be the zero point. At this time, the analog input value is 0.

When the zero reset is executed, the zero point correction is reset, and the analog input value returns to the original value.

Execution Method and Check Method

Use I/O data to execute the zero set or the zero reset and check the execution status.

Refer to 7-1 *Specifications of I/O Data* on page 7-2 for details on I/O data.

● How to Execute the Function

Set the Zero Set Execution bit in the Ch Operation Command of I/O data to execute the zero set or the zero reset.

● Execution Status Check

You can check the zero set or the zero reset execution status with the Ch Zero Set Executing bit in the Ch Executing Status of I/O data.

Description of Operation

The operations of zero set and zero reset are described below.

- When the Ch Zero Set Execution bit is changed from 0 to 1, the Ch Zero Set Executing bit changes from 0 to 1 and the zero set is executed. When the zero set is executed, the analog input value is corrected to be the zero point. At this time, the analog input value is 0. (Refer to (a) in the figure below.)
- When the Ch Zero Set Execution bit is changed from 1 to 0, the Ch Zero Set Executing bit changes from 1 to 0 and the zero reset is executed. When the zero reset is executed, the correction is reset. At this time, the analog input value returns to the original value. (Refer to (b) in the figure below.)

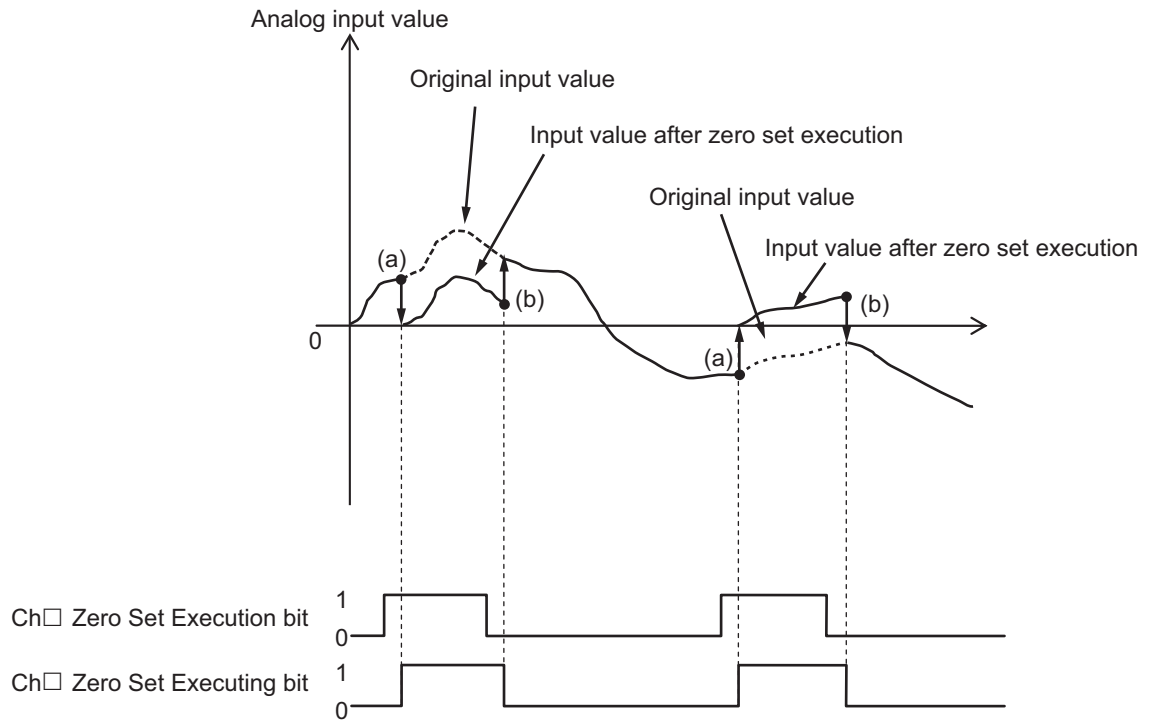

8-9-3 Setting Method

No setting is required.

8-10 Trigger Input

8-10-1 Function Applications and Overview

This function obtains the input value of the digital input signal to trigger analog input signals, and the DC time when the digital input value changes.

The function is used to identify the analog input signal that is obtained at the input timing of a digital input signal. It is used in combination with the Sysmac Library.

In the descriptions below, the "input of a digital input signal" is called "trigger input", and the "DC time when the input changed" is called the "input changed time".

8-10-2 Details on the Function

This section describes the following operations with the trigger function of the High-speed Analog Input Units.

- Trigger input operation

This function is used in combination with the analog inputs of the High-speed Analog Input Units, and cannot be used with NX Units that support output refreshing with specified time stamp.

Trigger Input Operation

This section describes the trigger input operation of the High-speed Analog Input Units. The operation is described for each Unit that the High-speed Analog Input Units can be connected to.

● CPU Unit Operation

The following describes the trigger input operation of the High-speed Analog Input Units connected to an NX-series CPU Unit.

- The High-speed Analog Input Units record input changed times for each trigger input bit. The Units record the DC times when status changes of the input terminals reach the internal circuits after the ON response time elapses.
If the input filter is used for the Input Filter Setting, the time set in the Input Filter Setting is added to the ON response time.
- The CPU Unit reads input values and input changed times from the High-speed Analog Input Units at I/O refreshing.
The CPU Unit reads the input values at I/O refreshing, instead of the input values at the point of time when the input changed times are recorded.
- The High-speed Analog Input Units that are connected to the CPU Unit read the input changed times at a fixed interval based on synchronization timing. (Refer to (a) in the figure below.)
- The High-speed Analog Input Units read input values at the timing of I/O refreshing, which is different from the timing of reading input changed times.
- The CPU Unit reads the input changed times and input values at I/O refreshing immediately after the input changed times are read. (Refer to (b) in the figure below.)
- The interval of I/O refreshing varies depending on the operational conditions of the CPU Unit. (Refer to (c) in the figure below.) Input changed times are read at a fixed interval. (Refer to (d) and (e) in the figure below.)

- The timing of reading input changed times, the synchronization timing, and the maximum NX bus I/O refresh cycle are automatically calculated by the Sysmac Studio according to the input refresh cycles of the NX Units on the CPU Unit when the Unit Configuration in the CPU Unit is created and set up.

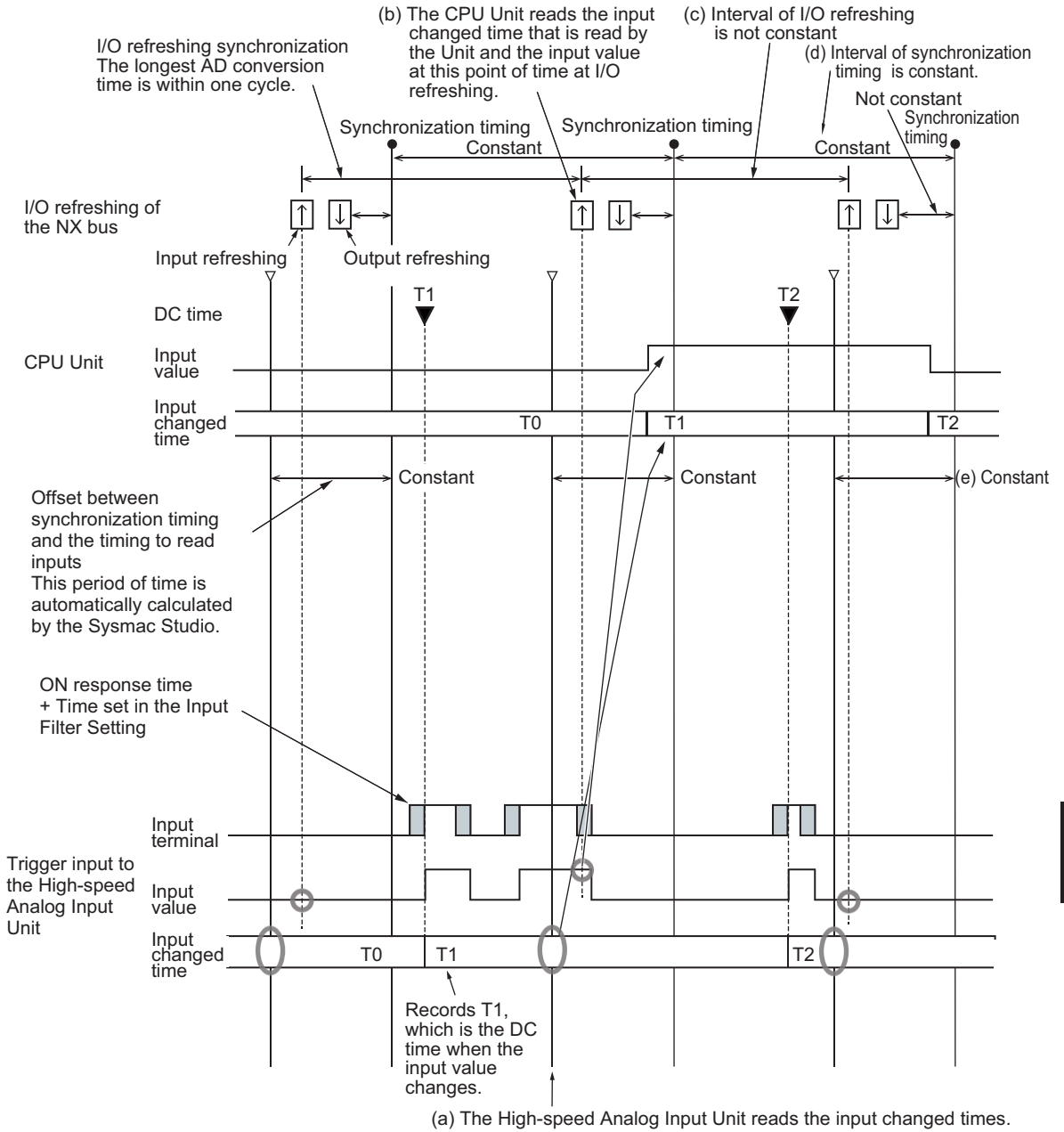

- The High-speed Analog Input Units detect changes at the rising edge of the trigger input.

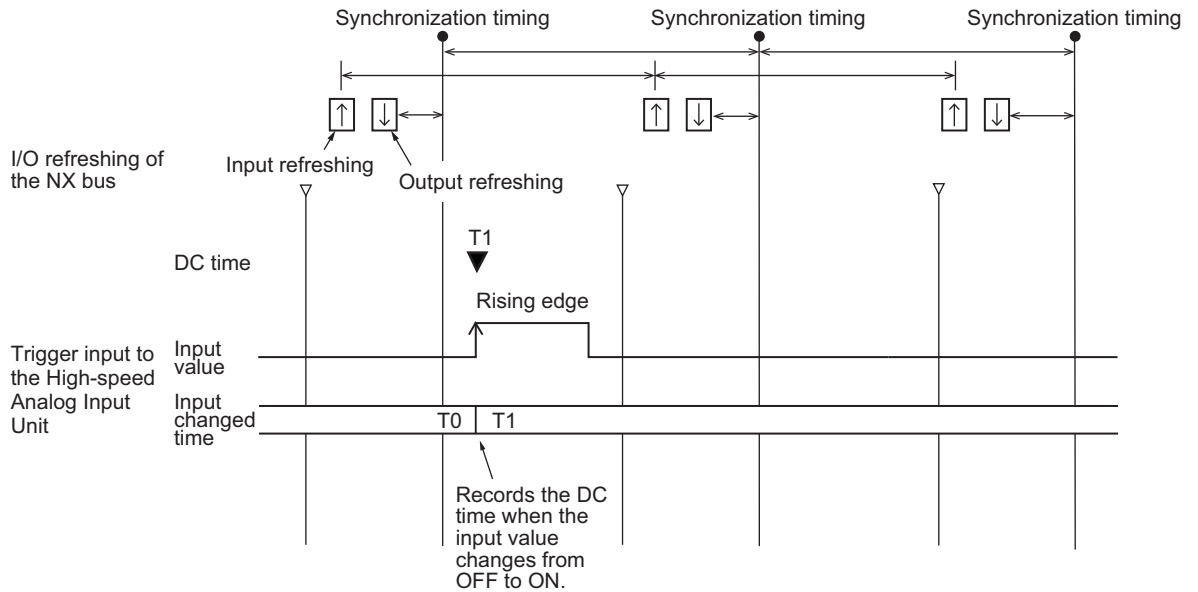

- If the trigger input changes from OFF to ON more than once during the NX bus I/O refresh cycle, the High-speed Analog Input Units record the DC time at the first change.

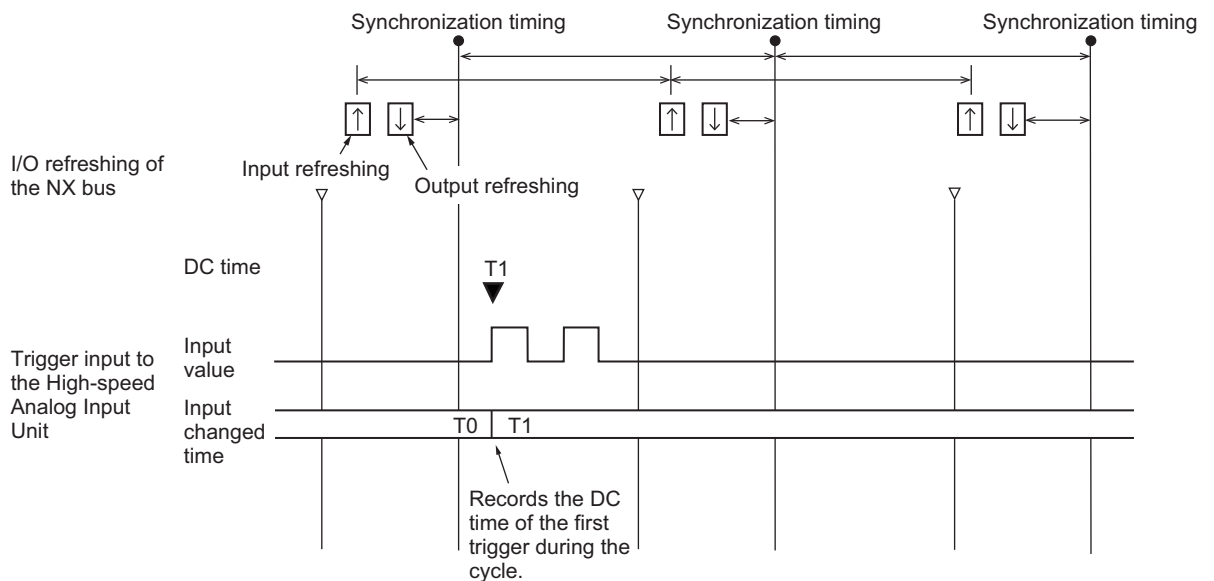

● Slave Terminal Operation

The following describes the trigger input operation of the High-speed Analog Input Units in an EtherCAT Slave Terminal connected to the built-in EtherCAT port.

- The High-speed Analog Input Units record input changed times for each trigger input bit. The Units record the DC times when status changes of the input terminals reach the internal circuits after the ON response time elapses.
If the input filter is used for the Input Filter Setting, the time set in the Input Filter Setting is added to the ON response time.
- The EtherCAT Coupler Unit reads input values and input changed times from the High-speed Analog Input Units at I/O refreshing.
The EtherCAT Coupler Unit reads input values at I/O refreshing, instead of the input values at the point of time when the input changed times are recorded.

- The High-speed Analog Input Units in the Slave Terminal read input changed times at a fixed interval based on Sync0. (Refer to (a) in the figure below.)*¹
 - The High-speed Analog Input Units read input values at the timing of I/O refreshing, which is different from the timing of reading input changed times.
 - The EtherCAT Coupler Unit reads the input changed times and input values at I/O refreshing immediately after the input changed times are read. (Refer to (b) in the figure below.)
 - The interval of I/O refreshing varies depending on the operational conditions of the EtherCAT Coupler Unit or the EtherCAT master. (Refer to (c) in the figure below.) Input changed times are read at a fixed interval. (Refer to (d) and (e) in the figure below.)
 - Sync0, the timing of reading input changed times, and the maximum NX bus I/O refresh cycle for multiple Slave Terminals are automatically calculated by the Sysmac Studio according to the input refresh cycles of the NX Units in the Slave Terminals when the Slave Terminals are configured and set up.
- *1. If multiple Slave Terminals are present on the same EtherCAT network, refer to *NX-series EtherCAT Coupler Units User's Manual (Cat. No. W519)* for the range of available Slave Terminals that operate at the same timing.

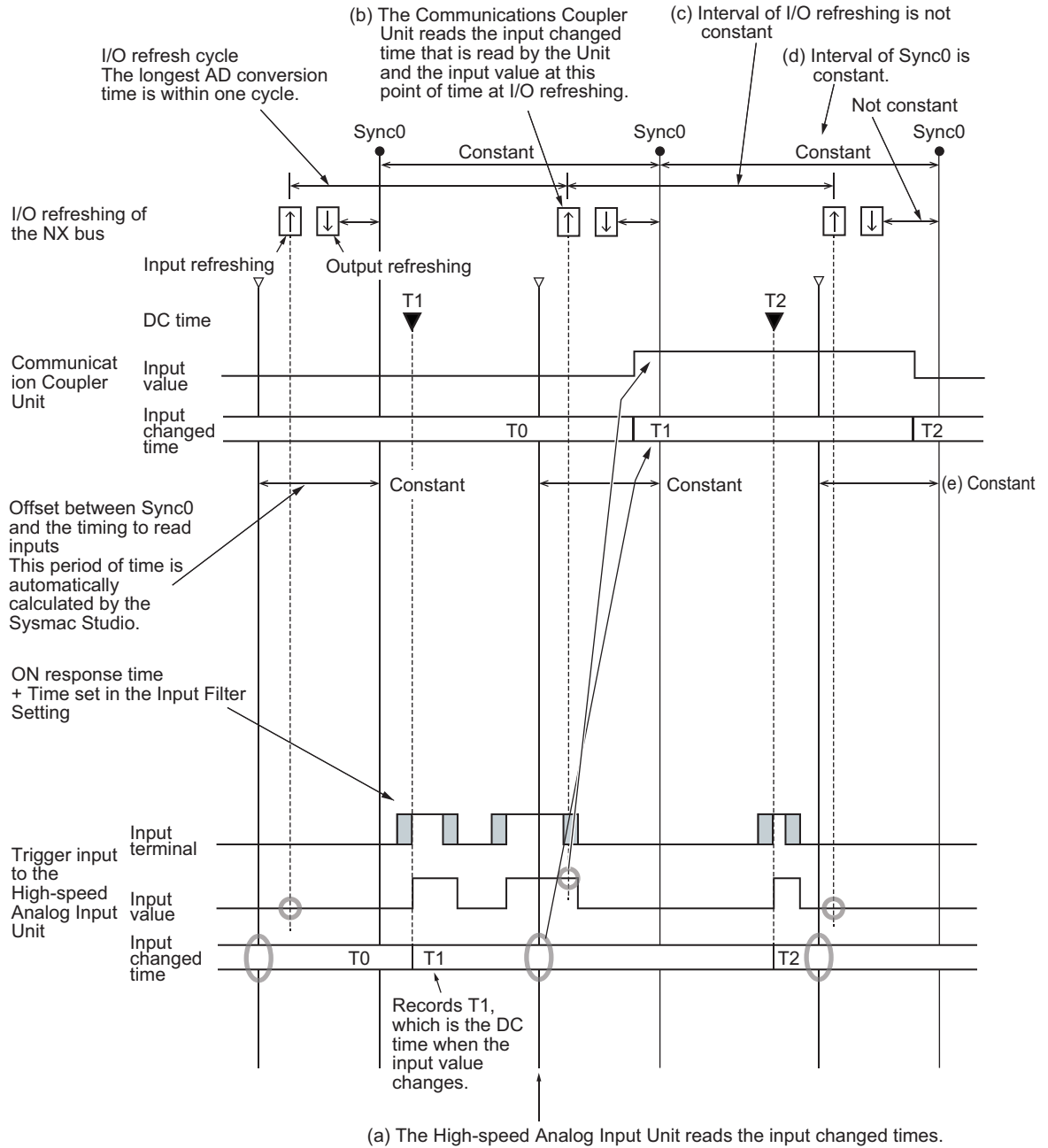

- The High-speed Analog Input Units detect changes at the rising edge of the trigger input.

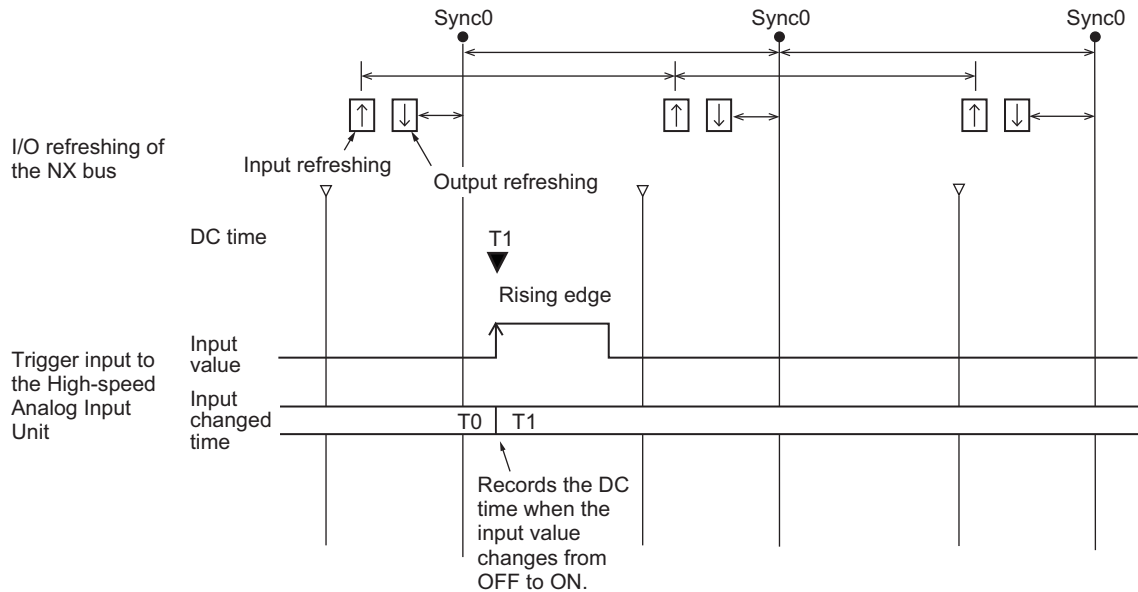

- If the trigger input changes from OFF to ON more than once during the NX bus I/O refresh cycle, the High-speed Analog Input Units record the DC time at the first change.

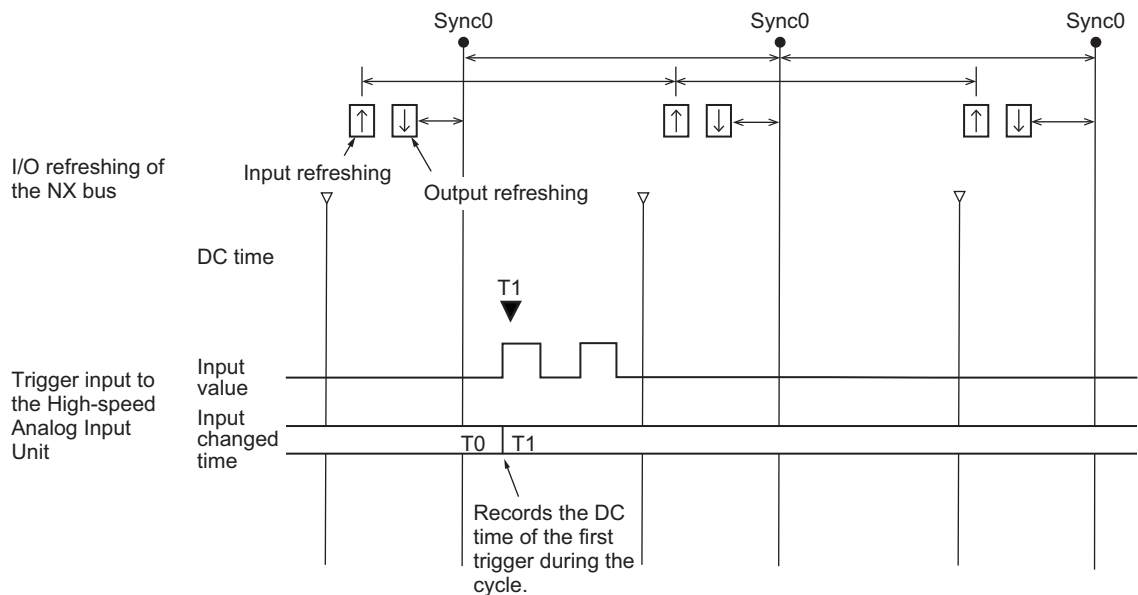

8-10-3 Identifying the Analog Input Value When Trigger Input Was Turned ON

The High-speed Analog Input Units have a library of the Sysmac Library prepared to identify and read an analog input value at the time when trigger input was turned ON. Refer to the *Sysmac Library User's Manual for High-speed Analog Inspection Library (Cat. No. W607)* for how to read values using the library.

This section describes how to identify the analog input value when trigger Input was turned ON, without using the library.

It provides a timing chart example and then the identification method to describe how to identify the Ch1 Analog Input Value when the Ch1 trigger input was turned ON under the following conditions.

- Task period of assigned periodic task: 1 ms
- Number of Ch1 samplings: 5

Timing Chart Example

The following figure shows the timing chart.

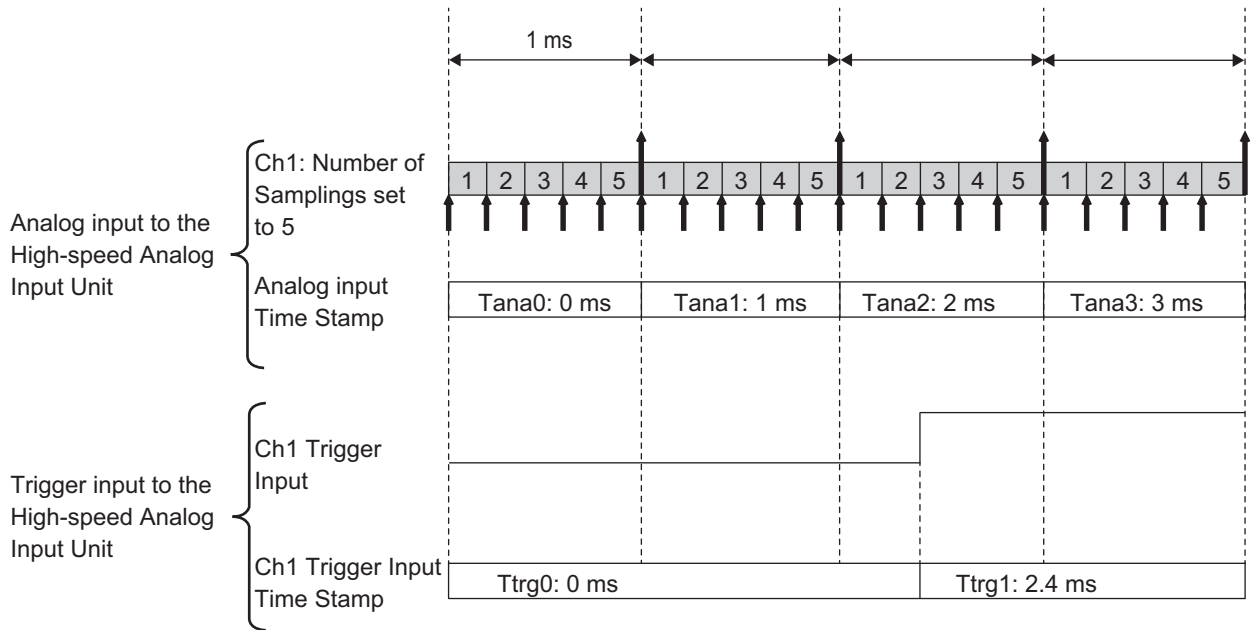

Identification Method

The identification method is described below.

- 1 Check the DC time of the Ch1 Trigger Input Time Stamp when the Ch1 trigger input was turned ON.

The Ch1 Trigger Input Time Stamps in the above timing chart example are shown in the following table.

Ch1 Trigger Input Time Stamp	
Symbol	DC time
Ttrg0	0 ms
Ttrg1	2.4 ms

The Ch1 Trigger Input Time Stamp when the Ch1 trigger input was turned ON is Ttrg1, and the DC time of Ttrg1 is 2.4 ms.

You can check the Trigger Input Time Stamp with the Ch□ Trigger Input Time Stamp of I/O data. Refer to *Ch□ Trigger Input Time Stamp* on page 7-8 for details on I/O data. The unit of the Ch□ Trigger Input Time Stamp of I/O data is ns.

- 2 Check the DC time of the Analog Input Time Stamp immediately before Ttrg1. The Analog Input Time Stamps in the above timing chart example are shown in the following table.

Ch1 Analog Input Time Stamp	
Symbol	DC time
Tana0	0 ms
Tana1	1 ms
Tana2	2 ms
Tana3	3 ms

The Analog Input Time Stamp immediately before Ttrg1 is Tana2. The DC time of Tana2 is 2 ms.

You can check the Analog Input Time Stamp with the Analog Input Time Stamp of I/O data. Refer to *Analog Input Time Stamp* on page 7-7 for details on I/O data. The unit of the Analog Input Time Stamp of I/O data is ns.

- 3** Calculate the DC time of each sampling of Ch1 Analog Input Value 1-10, whose sampling starts at Tana2.

The calculation formula for the DC time of the Nth sampling is as follows.

$$\text{DC time of the Nth sampling} = \text{Analog Input Time Stamp} + (\text{Task period of assigned periodic task} \div \text{Number of samplings}) \times (N - 1)$$

Since the task period of assigned periodic task is 1 ms, the number of samplings is 5, and the Analog Input Time Stamp Tana2 is 2 ms, the DC time of each sampling is calculated as follows.

Name	DC time
1st sampling	2 ms
2nd sampling	2.2 ms
3rd sampling	2.4 ms
4th sampling	2.6 ms
5th sampling	2.8 ms

- 4** Based on the above calculation results, identify the Ch1 Analog Input Value when the Ch1 trigger input was turned ON.

The DC time of Ttrg1, which is the Ch1 Trigger Input Time Stamp when the Ch1 trigger input was turned ON, is 2.4 ms. According to the table shown in step 3, the Analog Input Value of the third sampling of Ch1 Analog Input Value 1-10 is the same as the DC time of Ttrg1.

You can check the Analog Input Value with the Ch□ Analog Input Value of I/O data. Refer to *Ch□ Analog Input Value* on page 7-9 for details on I/O data.

8-10-4 Setting Method

No setting is required.

8-11 Input Filter

8-11-1 Function Applications and Overview

This function prevents data changes and unstable data if the input bits of the digital input signal that is used as trigger input are unstable due to chattering or noise.

8-11-2 Details on the Function

Read the inputs at a 1/4 interval of the input filter time. When all the inputs are ON or OFF, the input values turn ON or OFF.

This prevents data changes and unstable data.

The function works for each trigger input channel of the High-speed Analog Input Units.

Operation when the input turns from OFF to ON (ON filter)

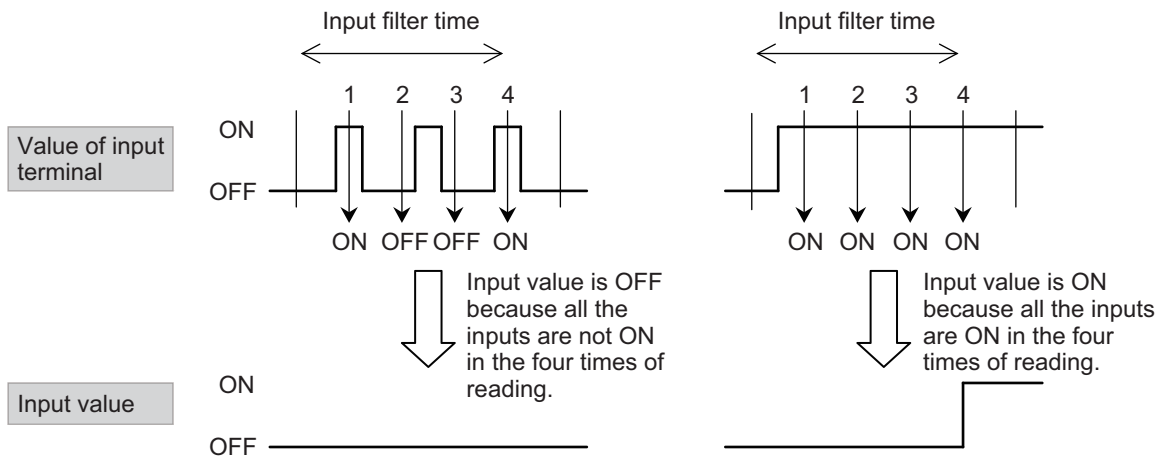

Operation when the input turns from ON to OFF (OFF filter)

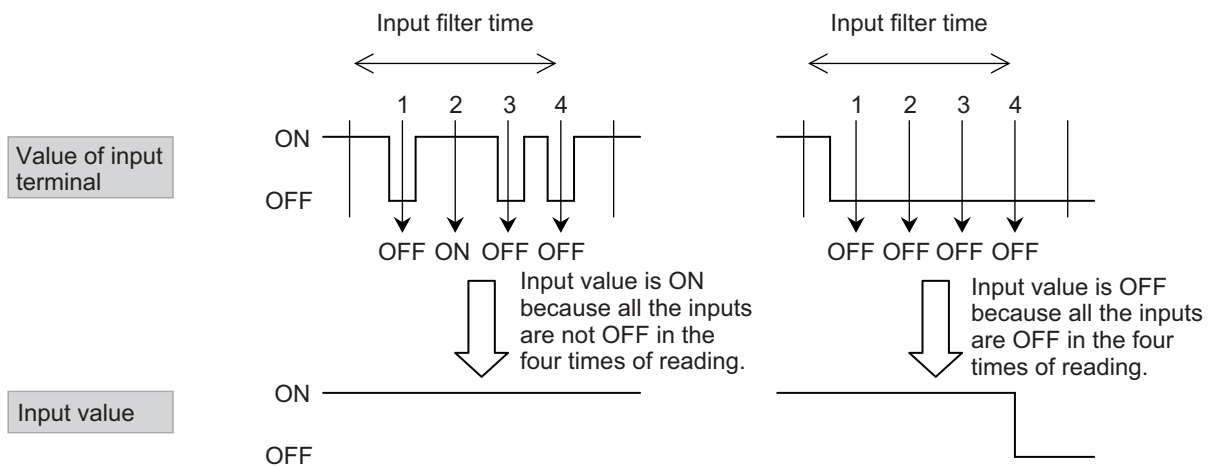

You can use this function to set the input filter value for each channel.

Set the input filter values in the Unit operation settings. The settings are shown in the following table.

Setting name	Setting description	Default value	Setting range	Unit	Update timing
Ch1 Input Filter Value Setting	Set the filter time for trigger input signals. Set one of the following:	4*2	0, or 3 to 9*1	---	Immediately
Ch2 Input Filter Value Setting					
Ch3 Input Filter Value Setting					
Ch4 Input Filter Value Setting					

*1. The meanings of the set values for **Ch□ Input Filter Value Setting** are as follows.

Set value	Meaning
0	No Filter
3	4 μs
4	8 μs
5	16 μs
6	32 μs
7	64 μs
8	128 μs
9	256 μs

*2. If a small value is set for the input filter time, incorrect input caused by external noises occurs more easily. If an incorrect input occurs, either change the setting to make a long input filter time or take countermeasures, such as separate the Unit or signal lines and noise source, or protect the Unit or signal lines. For examples of countermeasures, refer to *When the Unit is Easily Affected by Noise* on page 4-25.

● Precautions When You Change Set Values

If you use the actual system to adjust the values of settings that are designed to be updated immediately after a change, change the values of only those settings and transfer them to the Unit. Note that you need to restart the Unit if you change and transfer the values of settings that are designed to be updated only after a restart.

8-11-3 Setting Method

This section describes how to configure settings with the Sysmac Studio.

- 1** Display the Edit Unit Operation Settings Tab Page.
For how to display the tab page, refer to *A-8 Displaying the Edit Unit Operation Settings Tab Page* on page A-54.
- 2** Select the filter time from the list of **Trigger Input Filter Value Setting** for the channel (Ch□) you want to set.
Refer to *A-9 Edit Unit Operation Settings Tab Page* on page A-57 for how to edit the Unit operation settings.
- 3** Click the **Transfer to Unit** Button.
The settings are transferred from the Sysmac Studio to the NX Unit.

The settings are reflected immediately.

9

Troubleshooting

This section describes the error information and corrections for errors that can occur when the High-speed Analog Input Units are used.

9-1	How to Check for Errors	9-2
9-2	Checking for Errors with the Indicators	9-3
9-3	Checking for Errors and Troubleshooting on the Support Software	9-5
9-3-1	Checking for Errors from the Sysmac Studio	9-5
9-3-2	Checking for Errors from Support Software Other Than the Sysmac Studio	9-6
9-3-3	Event Codes and Corrections for Errors	9-6
9-3-4	Meaning of Error	9-12
9-4	Resetting Errors	9-35
9-5	Unit-specific Troubleshooting.....	9-36
9-6	Analog Input Value When an Error Occurs.....	9-39
9-7	Troubleshooting Flowchart	9-40

9-1 How to Check for Errors

Use one of the following error checking methods.

- Checking the indicators
- Troubleshooting with the Support Software

Refer to the troubleshooting manual for the CPU Unit or the user's manual for the Communications Coupler Unit that the NX Units are connected to for details on troubleshooting with the Support Software.

9-2 Checking for Errors with the Indicators

You can use the TS indicators on the High-speed Analog Input Units to check the NX Unit status and level of errors.

This section describes the meanings of errors that the TS indicator shows and the troubleshooting procedures for them.

In this section, the status of the indicator is indicated with the following abbreviations.

Abbreviation	Indicator status
Lit	Lit
Not Lit	Not lit
FS ()	Flashing. The numeric value in parentheses is the flashing interval.
---	Undefined

Main Errors and Corrections

The main errors and corrections for the High-speed Analog Input Units are given in the following table.

TS indicator*1		Cause	Correction
Green	Red		
Lit	Not Lit	---	--- (This is the normal status.)
FS (2 s)	Not Lit	<ul style="list-style-type: none"> Initializing Downloading 	--- (Normal. Wait until the processing is completed.)
Lit	Lit	This status is not present	
Not Lit	Not Lit	<p>The Unit power supply is not supplied.</p> <ul style="list-style-type: none"> Waiting for initialization to start Restarting <p>If you cannot resolve the problem after you check the above items and cycle the Unit power supply, the Unit may have a hardware failure. If this happens, replace the Unit. If this happens, replace the Unit.</p>	<p>Check the following items and supply the Unit power supply correctly. [Check Items for Power Supply]</p> <ul style="list-style-type: none"> Make sure that the power supply cable is wired correctly. Make sure that the power supply cable is not disconnected. Make sure that the power supply voltage is within the specified range. Make sure that the power supply has enough capacity. Make sure that power supply has not failed. <p>--- (Normal. Wait until the processing is completed.)</p>
Not Lit	Lit	Hardware failure	If this error occurs after you cycle the Unit power supply, replace the Unit.
Not Lit	Lit	Non-volatile Memory Hardware Error	Refer to Non-volatile Memory Hardware Error (page 9-14).
Not Lit	Lit	Analog Unit Calibration Parameter Error	Refer to Analog Unit Calibration Parameter Error (page 9-15).

TS indicator*1		Cause	Correction
Green	Red		
Not Lit	Lit	Control Parameter Error in Master	Refer to Control Parameter Error in Master (page 9-16).
Not Lit	Lit	NX Unit Processing Error	Refer to NX Unit Processing Error (page 9-20).
Not Lit	Lit	Number of Samplings Setting Error	Refer to Number of Samplings Setting Error (page 9-19).
Not Lit	Lit	I/O Allocation Setting Error	Refer to I/O Allocation Setting Error (page 9-18).
Not Lit	Lit	Unit Calibration Value Error	Refer to Unit Calibration Value Error (page 9-17).
Not Lit	Lit	NX Unit Clock Not Synchronized Error	Refer to NX Unit Clock Not Synchronized Error (page 9-26).
Not Lit	FS (1 s)	NX Unit I/O Communications Error	Refer to NX Unit I/O Communications Error (page 9-23).
Not Lit	FS (1 s)	NX Unit Output Synchronization Error	Refer to NX Unit Output Synchronization Error (page 9-25).
The indicator status is held immediately before the event occurred.		Unit I/O Disconnection Detected for Channel □	Refer to Unit I/O Disconnection Detected for Channel □ (page 9-21).
		Unit Over Range for Channel □	Refer to Unit Over Range for Channel □ (page 9-27).
		Unit Under Range for Channel □	Refer to Unit Under Range for Channel □ (page 9-29).

*1. In case of an indicator status that is not listed in the above table, a hardware failure may have occurred in the Unit. If the problem persists even after the power supply to the Unit is cycled, replace the Unit.

9-3 Checking for Errors and Troubleshooting on the Support Software

Error management on the NX Series is based on the methods used for the NJ/NX/NY-series Controllers.

This allows you to use the Support Software to check the meanings of errors and troubleshooting procedures.

The confirmation method depends on the Support Software that is used.

9-3-1 Checking for Errors from the Sysmac Studio

When an error occurs, you can place the Sysmac Studio online to the Controller or the Communications Coupler Unit to check current Controller errors and the log of past Controller errors.

Refer to the user's manual for the connected CPU Unit or Communications Coupler Unit for details on how to check errors.

Current Errors

Open the Sysmac Studio's Controller Error Tab Page to check the current error's level, source, source details, event name, event codes, details, attached information 1 to 4, and correction.

Errors in the observation level are not displayed.



Additional Information

Number of Current Errors

The following table gives the number of errors that are reported simultaneously as current errors in the High-speed Analog Input Units.

Unit	Number of simultaneous error notifications
High-speed Analog Input Unit	15 errors

If the number of errors exceeds the maximum number of reportable current errors, errors are reported with a priority given to the oldest and highest-level errors. Errors that exceed the limit on simultaneous error notifications are not reported.

Errors that are not reported are still reflected in the error status.

Log of Past Errors

Open the Sysmac Studio's Controller Event Log Tab Page to check the times, levels, sources, source details, event names, event codes, details, attached information 1 to 4, and corrections for previous errors.



Additional Information

Number of Logs of Past Errors

Event logs in the High-speed Analog Input Units are stored in the High-speed Analog Input Units itself.

The system event log can record 15 events. The access event log can record 2 events.

Refer to the troubleshooting manual for the connected CPU Unit or Industrial PC and the *Sysmac Studio Version 1 Operation Manual (Cat. No. W504)* for information on the items you can check and for how to check for errors.

Refer to 9-3-3 *Event Codes and Corrections for Errors* on page 9-6 for information on event codes.

9-3-2 Checking for Errors from Support Software Other Than the Sysmac Studio

For High-speed Analog Input Units, you cannot use Support Software other than the Sysmac Studio to check errors.

9-3-3 Event Codes and Corrections for Errors

The errors (i.e., events) that can occur in the High-speed Analog Input Units are given below. The following abbreviations are used in the event level column.

Abbreviation	Name
Maj	Major fault level
Prt	Partial fault level
Min	Minor fault level
Obs	Observation
Info	Information

Symbol	Meaning
○	Event levels that are defined by the system.
⊙	Event levels that can be changed by the user.

Note ⊙ appears only for events for which the user can change the event level.

Refer to the troubleshooting manual for the connected CPU Unit or Industrial PC for all NJ/NX/NY-series event codes.

Event code	Event name	Meaning	Assumed cause	Level					Reference
				Maj	Prt	Min	Obs	Info	
00200000 hex	Non-volatile Memory Hardware Error	An error occurred in non-volatile memory.	<ul style="list-style-type: none"> Non-volatile memory failure 			○			page 9-14

Event code	Event name	Meaning	Assumed cause	Level					Reference
				M a j	P r t	M i n	O b s	I n f o	
10400000 hex	Analog Unit Calibration Parameter Error	An error occurred for the calibration data in the Analog Unit.	<ul style="list-style-type: none"> The power supply to the Analog Unit was turned OFF or Support Software communications were disconnected while writing the calibration values to the Analog Unit. 			○			page 9-15
10410000 hex	Control Parameter Error in Master	An error occurred in the control parameters that are saved in the master.	<p>For the NX bus of CPU Units</p> <ul style="list-style-type: none"> The power supply to the CPU Unit was turned OFF while writing the Unit operation settings was in progress. Or there is an error in the area of the non-volatile memory in the CPU Unit in which the Unit operation settings for the NX Unit are saved. <p>For Communications Coupler Units</p> <ul style="list-style-type: none"> The power supply to the Communications Coupler Unit was turned OFF while writing the Unit operation settings was in progress. Or there is an error in the area of the non-volatile memory in the Communications Coupler Unit in which the Unit operation settings for the NX Unit are saved. 			○			page 9-16
10440000 hex	Unit Calibration Value Error	There is an error in the area in which the Unit calibration values are saved.	<ul style="list-style-type: none"> There is an error in the area of the non-volatile memory in which the Unit calibration values are saved. 			○			page 9-17

Event code	Event name	Meaning	Assumed cause	Level					Reference
				M a j	P r t	M i n	O b s	I n f o	
30070000 hex	I/O Allocation Setting Error	I/O allocations are not set correctly.	<p>For the NX bus of CPU Units</p> <ul style="list-style-type: none"> I/O Entry that matches the following setting items of unit operation settings has not been set in I/O allocation settings. <ul style="list-style-type: none"> Ch□ Number of Samplings Setting Ch□ Enable/Disable <p>For Communications Coupler Units</p> <ul style="list-style-type: none"> I/O Entry that matches the following setting items of unit operation settings has not been set in I/O allocation settings. <ul style="list-style-type: none"> Ch□ Number of Samplings Setting Ch□ Enable/Disable The Number of Samplings Setting was set to other than 1 and the Enable Distributed Clock setting for the EtherCAT Coupler Unit was set to Disabled. 			○			page 9-18
38970000 hex	Number of Samplings Setting Error	The sampling period is less than the lower limit of the conversion time for the Unit. The number of samplings is not set correctly.	<ul style="list-style-type: none"> The sampling period is less than the lower limit of the conversion time for the Unit. 			○			page 9-19
40200000 hex	NX Unit Processing Error	A fatal error occurred in an NX Unit.	<ul style="list-style-type: none"> An error occurred in the software. 			○			page 9-20
65030000 hex	Unit I/O Disconnection Detected for Channel 1	A disconnected input was detected for channel 1.	<ul style="list-style-type: none"> Input wiring is broken. Input wiring is disconnected. 			○	⊙		page 9-21
65040000 hex	Unit I/O Disconnection Detected for Channel 2	A disconnected input was detected for channel 2.	<ul style="list-style-type: none"> Input wiring is broken. Input wiring is disconnected. 			○	⊙		page 9-21
65050000 hex	Unit I/O Disconnection Detected for Channel 3	A disconnected input was detected for channel 3.	<ul style="list-style-type: none"> Input wiring is broken. Input wiring is disconnected. 			○	⊙		page 9-22

Event code	Event name	Meaning	Assumed cause	Level					Reference
				M a j	P r t	M i n	O b s	I n f o	
65060000 hex	Unit I/O Disconnection Detected for Channel 4	A disconnected input was detected for channel 4.	<ul style="list-style-type: none"> Input wiring is broken. Input wiring is disconnected. 			○	⊙		page 9-22
80200000 hex	NX Unit I/O Communications Error	An I/O communications error occurred in an NX Unit.	<p>For the NX bus of CPU Units</p> <ul style="list-style-type: none"> An error that prevents normal NX bus communications occurred in a CPU Unit. An NX Unit is not mounted properly. The power cable for the Unit power supply is disconnected, or the wiring from the Unit power supply to the NX Units is incorrect. The power cable for the Unit power supply is broken. The voltage of the Unit power supply is outside the specified range, or the capacity of the Unit power supply is insufficient. There is a hardware error in the NX Unit. <p>For Communications Coupler Units</p> <ul style="list-style-type: none"> An error that prevents normal NX bus communications occurred in a Communications Coupler Unit. An NX Unit is not mounted properly. The power cable for the Unit power supply is disconnected. Or, the wiring from the Unit power supply to the NX Units is incorrect. The power cable for the Unit power supply is broken. The voltage of the Unit power supply is outside the specified range. Or, the capacity of the Unit power supply is insufficient. There is a hardware error in the NX Unit. 			○			page 9-23

Event code	Event name	Meaning	Assumed cause	Level					Reference
				M a j	P r t	M i n	O b s	I n f o	
80210000 hex	NX Unit Output Synchronization Error	An output synchronization error occurred in the NX Unit.	<p>For the NX bus of CPU Units</p> <ul style="list-style-type: none"> I/O refreshing on the NX bus is not performed normally due to an error in the CPU Unit. <p>For Communications Coupler Units</p> <ul style="list-style-type: none"> The communications cable connected to the Communications Coupler Unit is broken or the connection is faulty. The communication cable is affected by noise. 			○			page 9-25
80240000 hex	NX Unit Clock Not Synchronized Error	A time information error occurred in an NX Unit.	<p>For the NX bus of CPU Units</p> <ul style="list-style-type: none"> There is a hardware error in an NX Unit. There is a hardware error in a CPU Unit. <p>For Communications Coupler Units</p> <ul style="list-style-type: none"> There is a hardware error in an NX Unit. There is a hardware error in an EtherCAT Coupler Unit. 			○			page 9-26
64F00000 hex	Unit Over Range for Channel 1	The analog input data for input channel 1 exceeded the upper limit of the input range. Or, the analog output data for output channel 1 exceeded the upper limit of the output range.	<ul style="list-style-type: none"> The analog input data exceeded the upper limit of the input range. Or, the analog output data exceeded the upper limit of the output range. 			◉	○		page 9-27
64F10000 hex	Unit Over Range for Channel 2	The analog input data for input channel 2 exceeded the upper limit of the input range. Or, the analog output data for output channel 2 exceeded the upper limit of the output range.	<ul style="list-style-type: none"> The analog input data exceeded the upper limit of the input range. Or, the analog output data exceeded the upper limit of the output range. 			◉	○		page 9-27

Event code	Event name	Meaning	Assumed cause	Level					Reference
				M a j	P r t	M i n	O b s	I n f o	
64F20000 hex	Unit Over Range for Channel 3	The analog input data for input channel 3 exceeded the upper limit of the input range. Or, the analog output data for output channel 3 exceeded the upper limit of the output range.	<ul style="list-style-type: none"> The analog input data exceeded the upper limit of the input range. Or, the analog output data exceeded the upper limit of the output range. 			⊙	○		page 9-28
64F30000 hex	Unit Over Range for Channel 4	The analog input data for input channel 4 exceeded the upper limit of the input range. Or, the analog output data for output channel 4 exceeded the upper limit of the output range.	<ul style="list-style-type: none"> The analog input data exceeded the upper limit of the input range. Or, the analog output data exceeded the upper limit of the output range. 			⊙	○		page 9-28
64F80000 hex	Unit Under Range for Channel 1	The analog input data for input channel 1 went below the lower limit of the input range. Or, the analog output data for output channel 1 went below the lower limit of the output range.	<ul style="list-style-type: none"> The analog input data went below the lower limit of the input range. Or, the analog output data went below the lower limit of the output range. 			⊙	○		page 9-29
64F90000 hex	Unit Under Range for Channel 2	The analog input data for input channel 2 went below the lower limit of the input range. Or, the analog output data for output channel 2 went below the lower limit of the output range.	<ul style="list-style-type: none"> The analog input data went below the lower limit of the input range. Or, the analog output data went below the lower limit of the output range. 			⊙	○		page 9-30
64FA0000 hex	Unit Under Range for Channel 3	The analog input data for input channel 3 went below the lower limit of the input range. Or, the analog output data for output channel 3 went below the lower limit of the output range.	<ul style="list-style-type: none"> The analog input data went below the lower limit of the input range. Or, the analog output data went below the lower limit of the output range. 			⊙	○		page 9-31

Event code	Event name	Meaning	Assumed cause	Level					Reference
				M a j	P r t	M i n	O b s	I n f o	
64FB0000 hex	Unit Under Range for Channel 4	The analog input data for input channel 4 went below the lower limit of the input range. Or, the analog output data for output channel 4 went below the lower limit of the output range.	<ul style="list-style-type: none"> The analog input data went below the lower limit of the input range. Or, the analog output data went below the lower limit of the output range. 			○	○		page 9-32
80220000 hex	NX Message Communications Error	An error was detected in message communications and the message frame was discarded.	<p>For the NX bus of CPU Units</p> <ul style="list-style-type: none"> The message communications load is high. <p>For Communications Coupler Units</p> <ul style="list-style-type: none"> The message communications load is high. The communications cable is disconnected or broken. Message communications were cutoff in communications. 				○		page 9-33
90400000 hex	Event Log Cleared	The event log was cleared.	<ul style="list-style-type: none"> The event log was cleared by the user. 					○	page 9-34

9-3-4 Meaning of Error

This section describes the information that is given for individual errors.

How to Read Error Descriptions

The items that are used to describe individual errors (events) are described in the following copy of an error table.

Event name	Gives the name of the error.		Event code	Gives the code of the error.		
Meaning	Gives a short description of the error.					
Source	Gives the source of the error.		Source details	Gives details on the source of the error.	Detection timing	Tells when the error is detected.
	Level	Tells the level of influence on control. *1				
Error attributes	Recovery	Gives the recovery method. *3				
	User program	Tells what will happen to execution of the user program. *4	Operation	Provides special information on the operation that results from the error.		
Indicators	Gives the status of the built-in EtherNet/IP port and built-in EtherCAT port indicators. Indicator status is given only for errors in the EtherCAT Master Function Module and the EtherNet/IP Function Module.					
System-defined variables	Variable	Data type	Name			
	Lists the variable names, data types, and meanings for system-defined variables that provide direct error notification, that are directly affected by the error, or that contain settings that cause the error.					
Cause and correction	Assumed cause	Correction	Prevention			
	Lists the possible causes, corrections, and preventive measures for the error.					
Attached information	This is the attached information that is displayed by the Support Software or an HMI. *5, *6					
Precautions/Remarks	Provides precautions, restrictions, and supplemental information. If the user can set the event level, the event levels that can be set, the recovery method, operational information, and other information are also provided.					

*1. One of the following:

- Major fault: Major fault level
- Partial fault: Partial fault level
- Minor fault: Minor fault level
- Observation
- Information

*2. One of the following:

- System: System event log
- Access: Access event log

*3. One of the following:

- Automatic recovery: Normal status is restored automatically when the cause of the error is removed.
- Error reset: Normal status is restored when the error is reset after the cause of the error is removed.
- Cycle the power supply: Normal status is restored when the power supply to the Controller is turned OFF and then back ON after the cause of the error is removed.
- Controller reset: Normal status is restored when the Controller is reset after the cause of the error is removed.
- Depends on cause: The recovery method depends on the cause of the error.

*4. One of the following:

- Continues: Execution of the user program will continue.
- Stops: Execution of the user program stops.
- Starts: Execution of the user program starts.

*5. "System information" indicates internal system information that is used by OMRON.

*6. Refer to the appendices of the troubleshooting manual for the connected CPU Unit or Industrial PC for the applicable range of the HMI Troubleshooter.

Error Descriptions

This section describes errors that occur in the High-speed Analog Input Units.

Event name	Non-volatile Memory Hardware Error		Event code	00200000 hex	
Meaning	An error occurred in non-volatile memory.				
Source	Depends on where the Support Software is connected and the system configuration.	Source details	NX Unit	Detection timing	When power is turned ON to the NX Unit
Error attributes	Level	Minor fault		Log category	System
	Recovery	<p>For the NX bus of CPU Units Cycle the power supply to the Unit or restart the NX bus.</p> <p>For Communications Coupler Units Cycle the power supply to the Unit or restart the Slave Terminal.</p> <p>If the errors are detected in the Controller, reset all of the errors in the Controller.</p>			
Effects	User program	Continues.	Operation	I/O refreshing for the NX Unit stops. Messages cannot be sent to the NX Unit.	
System-defined variables	Variable	Data type		Name	
	None	---		---	
	Assumed cause	Correction		Prevention	
	Non-volatile memory failure	<p>For the NX bus of CPU Units Cycle the power supply to the Unit or restart the NX bus. If the error persists even after you make the above correction, replace the relevant NX Unit.</p> <p>For Communications Coupler Units Cycle the power supply to the Unit or restart the Slave Terminal. If the error persists even after you make the above correction, replace the relevant NX Unit.</p>		None	
Attached information	None				
Precautions/Remarks	None				

Event name	Analog Unit Calibration Parameter Error		Event code	10400000 hex	
Meaning	An error occurred for the calibration data in the Analog Unit.				
Source	Depends on where the Support Software is connected and the system configuration.	Source details	NX Unit	Detection timing	When power is turned ON to the NX Unit
Error attributes	Level	Minor fault		Log category	System
	Recovery	<p>For the NX bus of CPU Units</p> <p>When Fail-soft Operation Is Set to Stop Restart the NX Unit and then reset the error in the NX Bus Function Module.</p> <p>When Fail-soft Operation Is Set to Fail-soft Restart the NX Unit.</p> <hr/> <p>For Communications Coupler Units</p> <p>When Fail-soft Operation Is Set to Stop Restart the NX Unit.</p> <p>If the errors are detected in the Controller, reset all of the errors in the Controller.</p> <p>When Fail-soft Operation Is Set to Fail-soft Restart the NX Unit.</p>			
Effects	User program	Continues.	Operation	I/O refreshing for the NX Unit stops.	
System-defined variables	Variable	Data type		Name	
	None	---		---	
Cause and correction	Assumed cause	Correction		Prevention	
	The power supply to the Analog Unit was turned OFF or Support Software communications were disconnected while writing the calibration values to the Analog Unit.	Write the calibration values to the Analog Unit again.		Do not turn OFF the power supply to the Analog Unit or disconnect Support Software communications while writing the calibration values to the Analog Unit.	
Attached information	None				
Precautions/Remarks	None				

Event name	Control Parameter Error in Master		Event code	10410000 hex	
Meaning	An error occurred in the control parameters that are saved in the master.				
Source	Depends on where the Support Software is connected and the system configuration.	Source details	NX Unit		Detection timing When power is turned ON to the NX Unit
Error attributes	Level	Minor fault		Log category	System
	Recovery	<p>For the NX bus of CPU Units</p> <p>When Fail-soft Operation Is Set to Stop Restart the NX Unit and then reset the error in the NX Bus Function Module.</p> <p>When Fail-soft Operation Is Set to Fail-soft Restart the NX Unit and then reset the error in the NX Unit.</p> <hr/> <p>For Communications Coupler Units</p> <p>When Fail-soft Operation Is Set to Stop If the errors are detected in the Controller, restart the NX Unit and then reset all of the errors in the Controller. If the errors are not detected in the Controller, restart the NX Unit and then reset the error in the Communications Coupler Unit.</p> <p>When Fail-soft Operation Is Set to Fail-soft Restart the NX Unit and then reset the error in the Communications Coupler Unit.</p>			
Effects	User program	Continues.	Operation	I/O refreshing for the NX Unit stops.	
System-defined variables	Variable	Data type	Name		
	None	---	---		
Cause and correction	Assumed cause	Correction		Prevention	
	For the NX bus of CPU Units				
	The power supply to the CPU Unit was turned OFF while writing the Unit operation settings was in progress. Or there is an error in the area of the non-volatile memory in the CPU Unit in which the Unit operation settings for the relevant NX Unit are saved.	Download the Unit operation settings of the NX Unit again. If the error persists even after you make the above correction, replace the CPU Unit.		Do not turn OFF the power supply to the CPU Unit while transfer of the Unit operation settings for the NX Unit or save of NX Unit parameters by a message is in progress.	
	For Communications Coupler Units				
The power supply to the Communications Coupler Unit was turned OFF while writing the Unit operation settings was in progress. Or there is an error in the area of the non-volatile memory in the Communications Coupler Unit in which the Unit operation settings for the relevant NX Unit are saved.	Download the Unit operation settings of the NX Unit again. If the error occurs again even after you make the above correction, replace the Communication Coupler Unit.		Do not turn OFF the power supply to the Communications Coupler Unit while transfer of the Unit operation settings for the NX Unit by the Support Software or save of NX Unit parameters by a message is in progress.		
Attached information	None				
Precautions/Remarks	None				

Event name	Unit Calibration Value Error		Event code	10440000 hex	
Meaning	There is an error in the area in which the Unit calibration values are saved.				
Source	Depends on where the Support Software is connected and the system configuration.	Source details	NX Unit	Detection timing	When power is turned ON to the NX Unit
Error attributes	Level	Minor fault		Log category	System
	Recovery	---			
Effects	User program	Continues.	Operation	The NX Unit will continue to operate. Input data: Updating input values stops.	
System-defined variables	Variable	Data type		Name	
	None	---		---	
Cause and correction	Assumed cause	Correction		Prevention	
	There is an error in the area of the non-volatile memory in which the Unit calibration values are saved.	Cycle the power to the NX Unit and see if this clears the error. If the error occurs again even after you make the above correction, replace the NX Unit.		None	
Attached information	None				
Precautions/Remarks	None				

Event name	I/O Allocation Setting Error		Event code	30070000 hex	
Meaning	I/O allocations are not set correctly.				
Source	Depends on where the Support Software is connected and the system configuration.		Source details	NX Unit	Detection timing Continuously
Error attributes	Level	Minor fault		Log category	System
	Recovery	<p>For the NX bus of CPU Units Restart the NX bus.</p> <p>For Communications Coupler Units Restart the Slave Terminal.</p>			
Effects	User program	Continues.	Operation	I/O refreshing for the NX Unit stops.	
System-defined variables	Variable	Data type		Name	
	None	---		---	
Cause and correction	Assumed cause		Correction		Prevention
	For the NX bus of CPU Units				
	I/O Entry that matches the following setting items of unit operation settings has not been set in I/O allocation settings.		After you set the Ch□ Number of Samplings and Ch□ Enable/Disable settings, update the I/O Entry. By updating I/O Entry in the I/O Allocation Settings Window on the Support Software, necessary I/O Entry is automatically set. After this setting, download the Unit operation settings and the I/O allocation settings again.		After you set the Ch□ Number of Samplings and Ch□ Enable/Disable settings, update the I/O Entry. By updating I/O Entry in the I/O Allocation Settings Window on the Support Software, necessary I/O Entry is automatically set.
	<ul style="list-style-type: none"> Ch□ Number of Samplings Setting Ch□ Enable/Disable 				
For Communications Coupler Units					
I/O Entry that matches the following setting items of unit operation settings has not been set in I/O allocation settings.		After you set the Ch□ Number of Samplings and Ch□ Enable/Disable settings, update the I/O Entry. By updating I/O Entry in the I/O Allocation Settings Window on the Support Software, necessary I/O Entry is automatically set. After this setting, download the Unit operation settings and the I/O allocation settings again.		After you set the Ch□ Number of Samplings and Ch□ Enable/Disable settings, update the I/O Entry. By updating I/O Entry in the I/O Allocation Settings Window on the Support Software, necessary I/O Entry is automatically set.	
<ul style="list-style-type: none"> Ch□ Number of Samplings Setting Ch□ Enable/Disable 					
The Number of Samplings Setting was set to other than 1 and the Enable Distributed Clock setting for the EtherCAT Coupler Unit was set to Disabled.		Set the Enable Distributed Clock setting for the EtherCAT Coupler Unit to Enabled (DC for synchronization) or Enabled (DC with priority in cycle time) and then download the Slave Terminal parameter settings again.		For the High-speed Analog Input Units, synchronous I/O refreshing is always used. Therefore, set the Enable Distributed Clock setting for the EtherCAT Coupler Unit to Enabled (DC for synchronization) or Enabled (DC with priority in cycle time).	
Attached information	None				
Precautions/Remarks	None				

Event name	Number of Samplings Setting Error		Event code	38970000 hex	
Meaning	The sampling period is less than the lower limit of the conversion time for the Unit. The number of samplings is not set correctly.				
Source	Depends on where the Support Software is connected and the system configuration.	Source details	NX Unit	Detection timing	Continuously
Error attributes	Level	Minor fault		Log category	System
	Recovery	For the NX bus of CPU Units Restart the NX bus. For Communications Coupler Units Restart the Slave Terminal.			
Effects	User program	Continues.	Operation	I/O refreshing for the NX Unit stops.	
System-defined variables	Variable	Data type		Name	
	None	---		---	
Cause and correction	Assumed cause	Correction		Prevention	
	The sampling period is less than the lower limit of the conversion time for the Unit.	Review the following settings to ensure that the sampling period is not below the lower limit of the conversion time for the Unit. <ul style="list-style-type: none"> Number of samplings for channels in which an error occurred Task periods of assigned periodic tasks After you set the number of samplings again, also set the I/O allocation settings again. After this setting, download the Unit operation settings and the I/O allocation settings again. If you set the task periods of assigned periodic tasks again, download the task settings to the Controller again.		Ensure that the sampling period is not below the lower limit of the conversion time for the Unit.	
Attached information	Attached information 1: Error channel 0001 hex: Channel 1 0010 hex: Channel 2 0100 hex: Channel 3 1000 hex: Channel 4 If this error occurs at the same time for more than one channel, the sum of the codes is given. For example, if errors occur at the same time for all of channels 1 to 4, then 1111 hex is given.				
Precautions/Remarks	None				

Event name	NX Unit Processing Error		Event code	40200000 hex	
Meaning	A fatal error occurred in an NX Unit.				
Source	Depends on where the Support Software is connected and the system configuration.	Source details	NX Unit	Detection timing	Continuously
Error attributes	Level	Minor fault		Log category	System
	Recovery	<p>For the NX bus of CPU Units</p> <ul style="list-style-type: none"> • Cycle the power supply to the NX Unit and then reset the error in the NX Bus Function Module. <p>For Communications Coupler Units</p> <ul style="list-style-type: none"> • Cycle the power supply to the NX Unit and then reset the error in the Communications Coupler Unit. 			
Effects	User program	Continues.	Operation	I/O refreshing for the NX Unit stops. Messages cannot be sent to the NX Unit.	
System-defined variables	Variable	Data type		Name	
	None	---		---	
Cause and correction	Assumed cause	Correction		Prevention	
	An error occurred in the software.	<p>For the NX bus of CPU Units</p> <p>Cycle the power supply to the Unit, restart the NX Unit, or restart the NX bus. If this error occurs again even after the above correction, contact your OMRON representative.</p> <p>For Communications Coupler Units</p> <p>Cycle the power supply to the Unit, restart the NX Unit, or restart the Slave Terminal. If this error occurs again even after the above correction, contact your OMRON representative.</p>		None	
Attached information	<p>Attached information 1: System Information</p> <p>Attached information 2: System Information</p> <p>Attached information 3: System Information</p> <p>Attached information 4: System Information</p>				
Precautions/Remarks	None				

Event name	Unit I/O Disconnection Detected for Channel 1		Event code	65030000 hex	
Meaning	A disconnected input was detected for channel 1.				
Source	Depends on where the Support Software is connected and the system configuration.	Source details	NX Unit	Detection timing	Continuously
Error attributes	Level	Minor fault		Log category	System
	Recovery	Reset error in the NX Unit.			
Effects	User program	Continues.	Operation	The converted value will be 32,767. Operation continues and the converted value returns to normal when the connection is restored.	
	System-defined variables	Variable	Data type	Name	
Cause and correction	Assumed cause	Correction		Prevention	
	Input wiring is broken.	Check the input wiring for breaks and replace the cable if any are found.		Check the cable for broken wires.	
	Input wiring is disconnected.	Check the input wiring for bad connections and reconnect any bad connections that are found.		Make sure that the wiring is connected properly.	
Attached information	None				
Precautions/Remarks	You can change the event level to the observation level.				

Event name	Unit I/O Disconnection Detected for Channel 2		Event code	65040000 hex	
Meaning	A disconnected input was detected for channel 2.				
Source	Depends on where the Support Software is connected and the system configuration.	Source details	NX Unit	Detection timing	Continuously
Error attributes	Level	Minor fault		Log category	System
	Recovery	Reset error in the NX Unit.			
Effects	User program	Continues.	Operation	The converted value will be 32,767. Operation continues and the converted value returns to normal when the connection is restored.	
	System-defined variables	Variable	Data type	Name	
Cause and correction	Assumed cause	Correction		Prevention	
	Input wiring is broken.	Check the input wiring for breaks and replace the cable if any are found.		Check the cable for broken wires.	
	Input wiring is disconnected.	Check the input wiring for bad connections and reconnect any bad connections that are found.		Make sure that the wiring is connected properly.	
Attached information	None				
Precautions/Remarks	You can change the event level to the observation level.				

Event name	Unit I/O Disconnection Detected for Channel 3		Event code	65050000 hex	
Meaning	A disconnected input was detected for channel 3.				
Source	Depends on where the Support Software is connected and the system configuration.		Source details	NX Unit	Detection timing Continuously
Error attributes	Level	Minor fault		Log category	System
	Recovery	Reset error in the NX Unit.			
Effects	User program	Continues.	Operation	The converted value will be 32,767. Operation continues and the converted value returns to normal when the connection is restored.	
System-defined variables	Variable	Data type		Name	
	None	---		---	
Cause and correction	Assumed cause	Correction		Prevention	
	Input wiring is broken.	Check the input wiring for breaks and replace the cable if any are found.		Check the cable for broken wires.	
	Input wiring is disconnected.	Check the input wiring for bad connections and reconnect any bad connections that are found.		Make sure that the wiring is connected properly.	
Attached information	None				
Precautions/Remarks	You can change the event level to the observation level.				

Event name	Unit I/O Disconnection Detected for Channel 4		Event code	65060000 hex	
Meaning	A disconnected input was detected for channel 4.				
Source	Depends on where the Support Software is connected and the system configuration.		Source details	NX Unit	Detection timing Continuously
Error attributes	Level	Minor fault		Log category	System
	Recovery	Reset error in the NX Unit.			
Effects	User program	Continues.	Operation	The converted value will be 32,767. Operation continues and the converted value returns to normal when the connection is restored.	
System-defined variables	Variable	Data type		Name	
	None	---		---	
Cause and correction	Assumed cause	Correction		Prevention	
	Input wiring is broken.	Check the input wiring for breaks and replace the cable if any are found.		Check the cable for broken wires.	
	Input wiring is disconnected.	Check the input wiring for bad connections and reconnect any bad connections that are found.		Make sure that the wiring is connected properly.	
Attached information	None				
Precautions/Remarks	You can change the event level to the observation level.				

Event name	NX Unit I/O Communications Error		Event code	80200000 hex	
Meaning	An I/O communications error occurred in an NX Unit.				
Source	Depends on where the Support Software is connected and the system configuration.	Source details	NX Unit	Detection timing	Continuously
Error attributes	Level	Minor fault		Log category	System
	Recovery	<p>For the NX bus of CPU Units</p> <p>When Fail-soft Operation Is Set to Stop Reset the error in the NX Bus Function Module.</p> <p>When Fail-soft Operation Is Set to Fail-soft Reset error in the NX Unit.</p> <hr/> <p>For Communications Coupler Units</p> <p>When Fail-soft Operation Is Set to Stop If the errors are detected in the Controller, reset all of the errors in the Controller.</p> <p>If the errors are not detected in the Controller, reset errors in the Communications Coupler Unit and NX Unit.</p> <p>When Fail-soft Operation Is Set to Fail-soft Reset errors in Communications Coupler Unit and NX Unit.</p>			
Effects	User program	Continues.	Operation	<p>The NX Unit will continue to operate.</p> <p>Input data: Updating input values stops.</p> <p>Output data: The output values depend on the Load Rejection Output Setting.</p>	
System-defined variables	Variable	Data type		Name	
	None	---		---	
Cause and correction	Assumed cause	Correction		Prevention	
	For the NX bus of CPU Units				
	An error that prevents normal NX bus communications occurred in a CPU Unit.	Check the error that occurred in the CPU Unit and perform the required corrections.		Take preventive measures against the error that occurred in the CPU Unit.	
	An NX Unit is not mounted properly.	Mount the NX Units and End Cover securely and secure them with End Plates.		Mount the NX Units and End Cover securely and secure them with End Plates.	
	The power cable for the Unit power supply is disconnected, or the wiring from the Unit power supply to the NX Units is incorrect.	Wire the Unit power supply to the NX Units securely.		Wire the Unit power supply to the NX Units securely.	
	The power cable for the Unit power supply is broken.	If the power cable between the Unit power supply and the NX Units is broken, replace it.		None	
	The voltage of the Unit power supply is outside the specified range, or the capacity of the Unit power supply is insufficient.	Configure the power supply system configuration correctly according to the power supply design method.		Configure the power supply system configuration correctly according to the power supply design method.	
	There is a hardware error in the NX Unit.	If the error persists even after you make the above correction, replace the NX Unit.		None	

Cause and correction	For Communications Coupler Units		
	An error that prevents normal NX bus communications occurred in a Communications Coupler Unit.	Check the error that occurred in the Communication Coupler Unit and perform the required corrections.	Take preventive measures against the error that occurred in the Communication Coupler Unit.
	The NX Unit is not mounted properly.	Mount the NX Units and End Cover securely and secure them with End Plates.	Mount the NX Units and End Cover securely and secure them with End Plates.
	The power cable for the Unit power supply is disconnected. Or, the wiring from the Unit power supply to the NX Units is incorrect.	Correctly wire the Unit power supply to the NX Units.	Correctly wire the Unit power supply to the NX Units.
	The power cable for the Unit power supply is broken.	If the power cable between the Unit power supply and the NX Units is broken, replace it.	None
	The voltage of the Unit power supply is outside the specified range. Or, the capacity of the Unit power supply is insufficient.	Correctly configure the power supply system according to the power supply design methods.	Correctly configure the power supply system according to the power supply design methods.
	There is a hardware error in the NX Unit.	If the error occurs again even after you make the above correction, replace the NX Unit.	None
Attached information	None		
Precautions/Remarks	None		

Event name	NX Unit Output Synchronization Error		Event code	80210000 hex	
Meaning	An output synchronization error occurred in the NX Unit.				
Source	Depends on where the Support Software is connected and the system configuration.	Source details	NX Unit	Detection timing	Continuously
Error attributes	Level	Minor fault		Log category	System
	Recovery	For the NX bus of CPU Units Reset the error in the NX Bus Function Module. For Communications Coupler Units Reset all errors in Controller.			
Effects	User program	Continues.	Operation	The NX Unit will continue to operate. Input data: Updating input values stops. Output data: The output values depend on the Load Rejection Output Setting.	
System-defined variables	Variable	Data type		Name	
	None	---		---	
Cause and correction	Assumed cause	Correction		Prevention	
	For the NX bus of CPU Units				
	I/O refreshing on the NX bus is not performed normally due to an error in the CPU Unit.	Check the error that occurred in the CPU Unit and perform the required corrections.		Take preventive measures against the error that occurred in the CPU Unit.	
	For Communications Coupler Units				
The communications cable connected to the Communications Coupler Unit is broken or the connection is faulty.	Replace the communications cable or wire the cable correctly.		Wire the communications cable correctly.		
The communication cable is affected by noise.	Set the Consecutive Communications Error Detection Count parameter for the Communications Coupler Unit to a suitable value that will not cause problems in operation. Implement noise countermeasures if there is excessive noise.		Implement noise countermeasures. Refer to the operation manuals for the specific Units for the noise countermeasures.		
Attached information	None				
Precautions/Remarks	None				

Event name	NX Unit Clock Not Synchronized Error		Event code	80240000 hex	
Meaning	A time information error occurred in an NX Unit.				
Source	Depends on where the Support Software is connected and the system configuration.	Source details	NX Unit	Detection timing	Continuously
Error attributes	Level	Minor fault		Log category	System
	Recovery	For the NX bus of CPU Units Cycle the power supply to the Unit. For Communications Coupler Units Cycle the power supply to the Unit and then reset all of the errors in the Controller.			
Effects	User program	Continues.	Operation	The NX Unit will continue to operate. Input data: Updating input values stops. Output data: The output values depend on the Load Rejection Output Setting.	
System-defined variables	Variable	Data type		Name	
	None	---		---	
Cause and correction	Assumed cause	Correction		Prevention	
	For the NX bus of CPU Units				
	There is a hardware error in an NX Unit.	If the error occurs only in a specific NX Unit, replace the relevant NX Unit.		None	
	There is a hardware error in a CPU Unit.	If the error occurs in all of the NX Units mounted on a CPU Unit, replace the CPU Unit.		None	
	For Communications Coupler Units				
	There is a hardware error in an NX Unit.	If the error occurs only in a specific NX Unit, replace the relevant NX Unit.		None	
	There is a hardware error in an EtherCAT Coupler Unit.	If the error occurs in all of the NX Units mounted on a Communications Coupler Unit, replace the Communications Coupler Unit.		None	
Attached information	None				
Precautions/Remarks	None				

Event name	Unit Over Range for Channel 1		Event code	64F00000 hex	
Meaning	The analog input data for input channel 1 exceeded the upper limit of the input range. Or, the analog output data for output channel 1 exceeded the upper limit of the output range.				
Source	Depends on where the Support Software is connected and the system configuration.	Source details	NX Unit	Detection timing	Continuously
Error attributes	Level	Observation		Log category	System
	Recovery	Reset error in the NX Unit.			
Effects	User program	Continues.	Operation	If the input range is exceeded, the converted value will be the upper limit of the input range. If the output range is exceeded, the analog output will be the upper limit of the output range.	
System-defined variables	Variable	Data type		Name	
	None	---		---	
Cause and correction	Assumed cause	Correction		Prevention	
	The analog input data exceeded the upper limit of the input range. Or, the analog output data exceeded the upper limit of the output range.	Find the reason for exceeding the upper limit of the input or output range and make suitable corrections.		Find the reasons for exceeding the upper limit of the input or output range and take suitable preventive measures.	
Attached information	None				
Precautions/Remarks	You can change the event level to the minor fault level.				

Event name	Unit Over Range for Channel 2		Event code	64F10000 hex	
Meaning	The analog input data for input channel 2 exceeded the upper limit of the input range. Or, the analog output data for output channel 2 exceeded the upper limit of the output range.				
Source	Depends on where the Support Software is connected and the system configuration.	Source details	NX Unit	Detection timing	Continuously
Error attributes	Level	Observation		Log category	System
	Recovery	Reset error in the NX Unit.			
Effects	User program	Continues.	Operation	If the input range is exceeded, the converted value will be the upper limit of the input range. If the output range is exceeded, the analog output will be the upper limit of the output range.	
System-defined variables	Variable	Data type		Name	
	None	---		---	
Cause and correction	Assumed cause	Correction		Prevention	
	The analog input data exceeded the upper limit of the input range. Or, the analog output data exceeded the upper limit of the output range.	Find the reason for exceeding the upper limit of the input or output range and make suitable corrections.		Find the reasons for exceeding the upper limit of the input or output range and take suitable preventive measures.	
Attached information	None				
Precautions/Remarks	You can change the event level to the minor fault level.				

Event name	Unit Over Range for Channel 3		Event code	64F20000 hex	
Meaning	The analog input data for input channel 3 exceeded the upper limit of the input range. Or, the analog output data for output channel 3 exceeded the upper limit of the output range.				
Source	Depends on where the Support Software is connected and the system configuration.	Source details	NX Unit	Detection timing	Continuously
Error attributes	Level	Observation		Log category	System
	Recovery	Reset error in the NX Unit.			
Effects	User program	Continues.	Operation	If the input range is exceeded, the converted value will be the upper limit of the input range. If the output range is exceeded, the analog output will be the upper limit of the output range.	
System-defined variables	Variable	Data type		Name	
	None	---		---	
Cause and correction	Assumed cause	Correction		Prevention	
	The analog input data exceeded the upper limit of the input range. Or, the analog output data exceeded the upper limit of the output range.	Find the reason for exceeding the upper limit of the input or output range and make suitable corrections.		Find the reasons for exceeding the upper limit of the input or output range and take suitable preventive measures.	
Attached information	None				
Precautions/Remarks	You can change the event level to the minor fault level.				

Event name	Unit Over Range for Channel 4		Event code	64F30000 hex	
Meaning	The analog input data for input channel 4 exceeded the upper limit of the input range. Or, the analog output data for output channel 4 exceeded the upper limit of the output range.				
Source	Depends on where the Support Software is connected and the system configuration.	Source details	NX Unit	Detection timing	Continuously
Error attributes	Level	Observation		Log category	System
	Recovery	Reset error in the NX Unit.			
Effects	User program	Continues.	Operation	If the input range is exceeded, the converted value will be the upper limit of the input range. If the output range is exceeded, the analog output will be the upper limit of the output range.	
System-defined variables	Variable	Data type		Name	
	None	---		---	
Cause and correction	Assumed cause	Correction		Prevention	
	The analog input data exceeded the upper limit of the input range. Or, the analog output data exceeded the upper limit of the output range.	Find the reason for exceeding the upper limit of the input or output range and make suitable corrections.		Find the reasons for exceeding the upper limit of the input or output range and take suitable preventive measures.	
Attached information	None				
Precautions/Remarks	You can change the event level to the minor fault level.				

Event name	Unit Under Range for Channel 1		Event code	64F80000 hex	
Meaning	The analog input data for input channel 1 went below the lower limit of the input range. Or, the analog output data for output channel 1 went below the lower limit of the output range.				
Source	Depends on where the Support Software is connected and the system configuration.	Source details	NX Unit	Detection timing	Continuously
Error attributes	Level	Observation		Log category	System
	Recovery	Reset error in the NX Unit.			
Effects	User program	Continues.	Operation	If the input data goes below the input range, the converted value will be the lower limit of the input range. If the output data goes below the output range, the analog output will be the lower limit of the output range.	
System-defined variables	Variable	Data type		Name	
	None	---		---	
Cause and correction	Assumed cause	Correction		Prevention	
	The analog input data went below the lower limit of the input range. Or, the analog output data went below the lower limit of the output range.	Find the reason for going below the lower limit of the input or output range and make suitable corrections.		Find the reasons for going below the lower limit of the input or output range and take suitable preventive measures.	
Attached information	None				
Precautions/Remarks	You can change the event level to the minor fault level.				

Event name	Unit Under Range for Channel 2		Event code	64F90000 hex		
Meaning	The analog input data for input channel 2 went below the lower limit of the input range. Or, the analog output data for output channel 2 went below the lower limit of the output range.					
Source	Depends on where the Support Software is connected and the system configuration.		Source details	NX Unit	Detection timing	Continuously
Error attributes	Level	Observation		Log category	System	
	Recovery	Reset error in the NX Unit.				
Effects	User program	Continues.	Operation	If the input data goes below the input range, the converted value will be the lower limit of the input range. If the output data goes below the output range, the analog output will be the lower limit of the output range.		
System-defined variables	Variable	Data type		Name		
	None	---		---		
Cause and correction	Assumed cause	Correction		Prevention		
	The analog input data went below the lower limit of the input range. Or, the analog output data went below the lower limit of the output range.	Find the reason for going below the lower limit of the input or output range and make suitable corrections.		Find the reasons for going below the lower limit of the input or output range and take suitable preventive measures.		
Attached information	None					
Precautions/Remarks	You can change the event level to the minor fault level.					

Event name	Unit Under Range for Channel 3		Event code	64FA0000 hex	
Meaning	The analog input data for input channel 3 went below the lower limit of the input range. Or, the analog output data for output channel 3 went below the lower limit of the output range.				
Source	Depends on where the Support Software is connected and the system configuration.	Source details	NX Unit	Detection timing	Continuously
Error attributes	Level	Observation		Log category	System
	Recovery	Reset error in the NX Unit.			
Effects	User program	Continues.	Operation	If the input data goes below the input range, the converted value will be the lower limit of the input range. If the output data goes below the output range, the analog output will be the lower limit of the output range.	
	System-defined variables	Variable	Data type	Name	
		None	---	---	
Cause and correction	Assumed cause	Correction	Prevention		
	The analog input data went below the lower limit of the input range. Or, the analog output data went below the lower limit of the output range.	Find the reason for going below the lower limit of the input or output range and make suitable corrections.	Find the reasons for going below the lower limit of the input or output range and take suitable preventive measures.		
Attached information	None				
Precautions/Remarks	You can change the event level to the minor fault level.				

Event name	Unit Under Range for Channel 4		Event code	64FB0000 hex		
Meaning	The analog input data for input channel 4 went below the lower limit of the input range. Or, the analog output data for output channel 4 went below the lower limit of the output range.					
Source	Depends on where the Support Software is connected and the system configuration.		Source details	NX Unit	Detection timing	Continuously
Error attributes	Level	Observation		Log category	System	
	Recovery	Reset error in the NX Unit.				
Effects	User program	Continues.	Operation	If the input data goes below the input range, the converted value will be the lower limit of the input range. If the output data goes below the output range, the analog output will be the lower limit of the output range.		
System-defined variables	Variable	Data type		Name		
	None	---		---		
Cause and correction	Assumed cause	Correction		Prevention		
	The analog input data went below the lower limit of the input range. Or, the analog output data went below the lower limit of the output range.	Find the reason for going below the lower limit of the input or output range and make suitable corrections.		Find the reasons for going below the lower limit of the input or output range and take suitable preventive measures.		
Attached information	None					
Precautions/Remarks	You can change the event level to the minor fault level.					

Event name	NX Message Communications Error		Event code	80220000 hex	
Meaning	An error was detected in message communications and the message frame was discarded.				
Source	Depends on where the Support Software is connected and the system configuration.	Source details	NX Unit	Detection timing	During NX message communications
Error attributes	Level	Observation		Log category	System
	Recovery	---			
Effects	User program	Continues.	Operation	Not affected.	
System-defined variables	Variable	Data type		Name	
	None	---		---	
Cause and correction	Assumed cause	Correction		Prevention	
	For the NX bus of CPU Units				
	The message communications load is high.	Reduce the number of times that instructions are used to send NX messages.		Reduce the number of times that instructions are used to send NX messages.	
	For Communications Coupler Units				
	The message communications load is high.	Reduce the number of times that instructions are used to send NX messages.		Reduce the number of times that instructions are used to send NX messages.	
	The communications cable is disconnected or broken. This cause does not apply if attached information 2 is 0 (NX bus).	Connect the communications cable securely.		Connect the communications cable securely.	
Message communications were cutoff by executing the followings in message communications. <ul style="list-style-type: none"> • Transfer of parameters by the Support Software • Restoration of the backup data (if this error occurred in the EtherCAT Slave Terminal) • Disconnection of an EtherCAT slave (if this error occurred in the EtherCAT Slave Terminal) 	---		---		
Attached information	Attached information 1: System Information Attached information 2: Type of communications where error occurred 0: NX bus 1: EtherCAT 2: Serial communications (USB) 3: EtherNet/IP 65535: Internal Unit communications (routing)				
Precautions/Remarks	None				

Event name	Event Log Cleared		Event code	90400000 hex	
Meaning	The event log was cleared.				
Source	Depends on where the Support Software is connected and the system configuration.	Source details	NX Unit	Detection timing	When commanded from user
Error attributes	Level	Information		Log category	Access
	Recovery	---			
Effects	User program	Continues.	Operation	Not affected.	
System-defined variables	Variable	Data type		Name	
	None	---		---	
Cause and correction	Assumed cause	Correction		Prevention	
	The event log was cleared by the user.	---		---	
Attached information	Attached information: Events that were cleared <ul style="list-style-type: none"> • 1: The system event log was cleared. • 2: The access event log was cleared. 				
Precautions/Remarks	None				

9-4 Resetting Errors

Refer to the troubleshooting manual for the connected CPU Unit or the user's manual for the Communications Coupler Unit for information on how to reset errors.

9-5 Unit-specific Troubleshooting

The following table shows the errors, their assumed causes, and corrections for the High-speed Analog Input Units.

Problem	Assumed cause	Correction
The converted values or analog input values are different from expected or the error is too large.	The user calibration error is too large.	Execute the user calibration again.
	The required input is disabled.	Check to see if the setting is enabled.
	Wiring is incorrect. (Positive and negative are reversed etc.)	Check that the wiring is correct.
	The input range is not correct.	Check that the input range is correct.
	The short-circuit cable is longer than the specified length.	Cut the short-circuit cable to the specified length.
	A short-circuit cable is not connected.	Connect a short-cut cable when the input range is 0 to 20 mA or 4 to 20 mA.
	There is a problem with the Unit.	Cycle the power supply to the Unit. If the problem persists even after the power supply is cycled, replace the Unit.
	The digital filter settings are invalid.	Check that the digital low-pass filter cutoff frequency, Filter 1 Moving Average Count, and Filter 2 Moving Average Count settings of the digital filtering are correct.
	Task assignment is incorrect.	Assign the primary periodic task or the priority-5 periodic.
	The High-speed Analog Input Unit is not installed in the upright orientation.	The High-speed Analog Input Units can be installed only in the upright orientation, regardless of the destination to which they are connected. Install the High-speed Analog Input Unit in the upright orientation.
A Relay Output Unit (NX-OC□□□□) is connected next to the High-speed Analog Input Unit.	Do not connect a Relay Output Unit (NX-OC□□□□) next to the High-speed Analog Input Unit.	

Problem	Assumed cause	Correction
The disconnection indication does not clear.	An output device is disconnected.	Restore the output device connection. Check the output device and input type.
	The input is significantly out of the output device measurement range.	Check that the input is correct.
	Wiring is incorrect. (Positive and negative are reversed etc.)	Check that the wiring is correct.
	The user calibration error is too large.	Execute the user calibration again.
The disconnection detection is not performed.	The input range is not set to 1 to 5 V or 4 to 20 mA.	Check the input range.
	The line disconnection detection is disabled.	To use the line disconnection detection, set the Disconnection Detection Enable/Disable setting to Enable.
The user calibration is not accepted.	An attempt was made to make calibration with inputs outside the correction range.	Input the voltage/current within the correction range from the input device and make the calibration again. If the voltage/current within the correction range cannot be input, change the connecting method to the input device.
Although the external device connected to the trigger input terminal is ON, nothing is input and the IN indicator is not lit either.	The I/O power is not supplied.	Check that the I/O power is supplied.
	The I/O power supply voltage is outside the rated range.	Set the I/O power supply voltage within the rated range.
	The Unit is not wired correctly with the connected external device.	Check the wiring with the connected external device.
	The wiring to the connected external device is disconnected.	Check the wiring with the connected external device.
	A connected external device is defective.	Replace the connected external device.
	There is a problem with the Unit.	Cycle the power supply to the Unit. If the problem persists even after the power supply is cycled, replace the Unit.
	The High-speed Analog Input Unit is not installed in the upright orientation.	The High-speed Analog Input Units can be installed only in the upright orientation, regardless of the destination to which they are connected. Install the High-speed Analog Input Unit in the upright orientation.
	A Relay Output Unit (NX-OC□□□□) is connected next to the High-speed Analog Input Unit.	Do not connect a Relay Output Unit (NX-OC□□□□) next to the High-speed Analog Input Unit.

Problem	Assumed cause	Correction
The external device connected to the trigger input terminal is ON and the IN indicator is lit, but nothing is input.	An NX bus error or a communications error occurred.	When the Unit is connected to the CPU Unit, check if a NX bus error occurred. In the case of a Slave Terminal, check if a NX bus or host communication error occurred.
	The channel is selected to use, but disabled.	Set the selecting channel to use function to Enable.
There is a delay in the ON and OFF timing of the trigger input.	An input filter may be set.	Set the input filter value to 0. Alternatively, change the input filter to an appropriate value.

9-6 Analog Input Value When an Error Occurs

If an error is detected in the process of converting analog input data, the analog input is converted as shown in the table below. These converted values can tell you if the following errors have occurred.

Error name	Data name	Analog input value when an error occurs
Unit I/O Disconnection Detected for Channel <input type="checkbox"/>	Ch1 Data	32767
	Ch2 Data	32767
	Ch3 Data	32767
	Ch4 Data	32767
Unit Over Range for Channel <input type="checkbox"/>	Ch1 Data	Upper limit of convertible range
	Ch2 Data	Upper limit of convertible range
	Ch3 Data	Upper limit of convertible range
	Ch4 Data	Upper limit of convertible range
Unit Under Range for Channel <input type="checkbox"/>	Ch1 Data	Lower limit of convertible range
	Ch2 Data	Lower limit of convertible range
	Ch3 Data	Lower limit of convertible range
	Ch4 Data	Lower limit of convertible range

9-7 Troubleshooting Flowchart

Refer to the troubleshooting manual for the connected CPU Unit or the user's manual for the Communications Coupler Unit for information on the standard flow for troubleshooting errors.

10

Inspection and Maintenance

This section describes how to clean, inspect, and maintain the system.

10-1	Cleaning and Inspection	10-2
10-1-1	Cleaning	10-2
10-1-2	Periodic Inspections	10-2
10-2	Maintenance Procedures	10-5

10-1 Cleaning and Inspection

This section describes daily maintenance and the cleaning and inspection methods.

Inspect the High-speed Analog Input Units daily or periodically in order to keep it in optimal operating condition.

10-1-1 Cleaning

Clean the High-speed Analog Input Units regularly as described below in order to keep it in optimal operating condition.

- Wipe the equipment over with a soft, dry cloth when performing daily cleaning.
- If dirt remains even after wiping with a soft, dry cloth, wipe with a cloth that has been wet with a sufficiently diluted detergent (2%) and wrung dry.
- A smudge may remain on the NX Unit from gum, vinyl, or tape that was left on for a long time. Remove the smudge when cleaning.



Precautions for Correct Use

- Never use volatile solvents, such as paint thinner, benzene, or chemical wipes.
- Do not touch the NX bus connectors.

10-1-2 Periodic Inspections

Although the major components in NX Units have an extremely long life time, they can deteriorate under improper environmental conditions. Periodic inspections are thus required.

Inspection is recommended at least once every six months to a year, but more frequent inspections will be necessary in adverse environments.

Take immediate steps to correct the situation if any of the conditions in the following table are not met.

Periodic Inspection Items

No.	Inspection item	Inspection details	Criteria	Correction
1	External power supply	Is the power supply voltage measured at the terminal block within standards?	Within the power supply voltage range	Use a voltage tester to check the power supply at the terminals. Take necessary steps to bring the power supply within the power supply voltage range.
2	I/O power supply	Is the power supply voltage measured at the I/O terminal block within standards?	Voltages must be within I/O specifications of each NX Unit.	Use a voltage tester to check the power voltage at the terminals. Take necessary steps to bring the I/O power supply within NX Unit standards.

No.	Inspection item	Inspection details	Criteria	Correction
3	Ambient environment	Is the ambient operating temperature within standards?	0 to 55°C	Use a thermometer to check the temperature and ensure that the ambient operating temperature remains within the allowed range of 0 to 55°C.
		Is the ambient operating humidity within standards?	Relative humidity must be 10% to 95% with no condensation.	Use a hygrometer to check the humidity and ensure that the ambient operating humidity remains between 10% and 95%. Make sure that condensation does not occur due to rapid changes in temperature.
		Is it subject to direct sunlight?	Not in direct sunlight	Protect the Controller if necessary.
		Is there an accumulation of dirt, dust, salt, metal powder, etc.?	No accumulation	Clean and protect the Controller if necessary.
		Is there water, oil, or chemical sprays hitting the Controller?	No spray	Clean and protect the Controller if necessary.
		Are there corrosive or flammable gases in the area of the Controller?	No gases	Check by smell or use a sensor.
		Is the Unit subject to shock or vibration?	Vibration resistance and shock resistance must be within specifications.	Install cushioning or other vibration and shock absorbing equipment if necessary.
		Are there noise sources near the Controller?	No significant noise sources	Either separate the Controller and noise source or protect the Controller.
4	Installation and wiring	Are the DIN Track mounting hooks for each NX Unit securely locked?	No looseness	Securely lock the DIN Track mounting hooks.
		Are the cable connectors fully inserted and locked?	No looseness	Correct any improperly installed connectors.
		Are there any loose screws on the End Plates (PFP-M)?	No looseness	Tighten loose screws with a Phillips-head screwdriver.
		Are the NX Units connected to each other along the hookup guides and until they touch the DIN track?	You must connect and fix the NX Units to the DIN track.	Connect the NX Units to each other along the hookup guides and insert them until they touch the DIN track.
		Are there any damaged external wiring cables?	No visible damage	Check visually and replace cables if necessary.

Tools Required for Inspections

● Required Tools

- Phillips screwdriver
- Flat-blade screwdriver

- Voltage tester or digital voltmeter
- Industrial alcohol and pure cotton cloth

● **Tools Required Occasionally**

- Oscilloscope
- Thermometer and hygrometer

10-2 Maintenance Procedures

When you replace a High-speed Analog Input Unit, follow the procedure in the user's manual for the connected CPU Unit or Communications Coupler Unit.



Appendices

The appendices provide data sheets, dimensions, and other information for the High-speed Analog Input Units.

A-1	Data Sheet.....	A-2
A-1-1	Model List.....	A-2
A-1-2	High-speed Analog Input Units.....	A-3
A-2	Dimensions.....	A-11
A-3	Programming Examples for Analog Input Data Collection with the Library.....	A-13
A-3-1	System Configuration.....	A-13
A-3-2	Programming Example.....	A-13
A-3-3	Connection to the Communications Coupler Unit.....	A-17
A-4	Digital Filter Design with the Library.....	A-21
A-4-1	System Configuration.....	A-21
A-4-2	Digital Filter Design Examples.....	A-21
A-4-3	Programming Example.....	A-25
A-4-4	Connection to the Communications Coupler Unit.....	A-34
A-5	List of NX Objects.....	A-38
A-5-1	Format of NX Object Descriptions.....	A-38
A-5-2	Unit Information Objects.....	A-38
A-5-3	Objects That Accept I/O Allocations.....	A-40
A-5-4	Other Objects.....	A-45
A-6	Version Information with CPU Units.....	A-51
A-6-1	Relationship between Unit Versions of Units.....	A-51
A-7	Version Information with Communications Coupler Units.....	A-52
A-7-1	Connection to an EtherCAT Coupler Unit.....	A-52
A-8	Displaying the Edit Unit Operation Settings Tab Page.....	A-54
A-8-1	Connection to the CPU Unit.....	A-54
A-8-2	Slave Terminal.....	A-55
A-9	Edit Unit Operation Settings Tab Page.....	A-57
A-10	Displaying the User Calibration Window.....	A-59
A-10-1	Connection to the CPU Unit.....	A-59
A-10-2	Slave Terminal.....	A-60

A-1 Data Sheet

This section provides the specifications of the High-speed Analog Input Units.

A-1-1 Model List

Model	Analog input section					Trigger input section		I/O re-freshing method	Reference
	Number of points	Input range	Resolution	Input method	Conversion time	Number of points	Internal I/O common		
NX-HAD401	4 points	<ul style="list-style-type: none"> • -10 to 10 V • -5 to 5 V • 0 to 10 V • 0 to 5 V • 1 to 5 V • 0 to 20 mA • 4 to 20 mA 	*1	Differential input	5 μ s per channel	4 points	NPN	Synchronous I/O refreshing	page A-5
NX-HAD402						4 points	PNP		page A-8

- *1. Depending on the input range, the resolution becomes as follows.
- For -10 to 10 V and -5 to 5 V: 1/64000 (full scale)
 - For other ranges: 1/32000 (full scale)

A-1-2 High-speed Analog Input Units

Description of Items on Data Sheet of the High-speed Analog Input Units

The meanings of the items on the data sheet of the High-speed Analog Input Units are explained in the table below.

Item		Description
Unit name		The name of the Unit.
Model		The number of the Unit.
External connection terminals		The type of terminal block and connector that is used for connecting the Unit. The number of terminals on the terminal block is also described when a screwless clamping terminal block is used.
I/O refreshing method		The I/O refreshing methods that are used by the Unit. Only synchronous I/O refreshing is available.
Indicators		The type of indicators on the Unit and the layout of those indicators.*1
Analog input section	Number of points	The number of analog input points provided by the Unit.
	Input method	The analog signal input method provided by the Unit. Only differential input method is available.
	Input range	The input range of the Unit.
	Input conversion range	The conversion range of converted values for the full scale of the Unit. Input converted values range is fixed to the conversion limit value.
	Absolute maximum rating	The maximum value of analog input signals of the Unit. If a signal exceeding this range is input, the Unit may be damaged.
	Input impedance	The input impedance of the Unit.
	Resolution	The resolution of converted values of the Unit.
	Overall accuracy	The analog input conversion accuracy of the Unit. It is defined under the conditions of 25°C and 0 to 55°C.
	Conversion time	The time required to convert analog input signals of the Unit to the converted values.
Trigger input section	Number of points	The number of trigger input points provided by the Unit.
	Internal I/O common	The polarity of the input devices that are connected to the Unit. NPN connection and PNP connection are available.
	Rated input voltage	The rated input voltage and range of the Unit.
	Input current	The input current at the rated voltage of the Unit.
	ON voltage/ON current	The input voltage in which the Unit input turns ON, and corresponding input current.
	OFF voltage/OFF current	The input voltage in which the Unit input turns OFF, and corresponding input current.
	ON/OFF response time	The delay time for which the status change of the input terminals reaches the internal circuit of the Unit. The input filter time below is not included. It is described according to the ON/OFF sequence.
	Input filter time	The filter time when the status of the internal circuit is read as the data to the internal of the Unit. It is the same for both ON/OFF. The filter time to be set by the Support Software is described.
Dimensions		The dimensions of the Unit. They are described as W × H × D. The unit is "mm".

Item	Description
Isolation method	The isolation method between the input circuits and internal circuits and between the input circuits of the Unit.
Insulation resistance	The insulation resistance between the input circuits and internal circuits and between the input circuits of the Unit.
Dielectric strength	The dielectric strength between the input circuits and internal circuits and between the input circuits of the Unit.
I/O power supply method	The method for supplying I/O power for the Unit. The supply method is determined for each Unit. The power is supplied only from the NX bus.
Current capacity of I/O power supply terminals	The current capacity of the I/O power supply terminals (IOV/IOG) of the Unit. Do not exceed this value when you supply I/O power to external devices connected to the trigger input terminals of the Unit.
NX Unit power consumption	The power consumption of the NX Unit power supply of the Unit. The power consumption of the Unit connected to a CPU Unit and the power consumption of the Unit connected to a Communications Coupler Unit are separately given.
Current consumption from I/O power supply	The current consumption from I/O power supply of the Unit. This value does not include the input current to the trigger input terminals and the current consumption of external devices connected to the trigger input terminals.
Weight	The weight of the Unit.
Circuit Configuration	The input circuit layout of the Unit.
Installation orientation and restrictions	The installation orientation of a CPU Unit containing the Unit and the installation orientation of a Slave Terminal containing the Unit. Any restrictions to specifications that result from the installation orientation are also given.
Terminal connection diagram	A diagram of the connection between the Unit and connected external devices. When an I/O Power Supply Connection Unit or a Shield Connection Unit is required to be connected to the connected external devices, the description for such is included.
Input disconnection detection	The function of the Unit to detect an input disconnection. It detects disconnections only when the input range is 1 to 5 V or 4 to 20 mA.

*1. The layout of the indicators after the appearance change is shown for models released in or before March 2019. For details on the applicable models and the changes, refer to 3-2-3 *Appearance Change of the Indicators* on page 3-5.

Details on Data Sheet

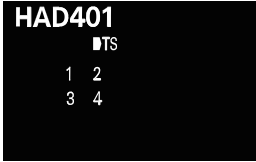
Unit name		High-speed Analog Input Unit	Model	NX-HAD401		
External connection terminals		Screwless clamping terminal block (16 terminals ×2)				
I/O refreshing method		Synchronous I/O refreshing				
Indicators		TS indicator, IN indicator				
						
Analog input section	Number of points	4 points		Trigger input section	Number of points	4 points
	Input method	Differential input			Internal I/O common	NPN
	Input range	Voltage: <ul style="list-style-type: none"> -10 to 10 V -5 to 5 V 0 to 10 V 0 to 5 V 1 to 5 V Current: <ul style="list-style-type: none"> 0 to 20 mA 4 to 20 mA 			Rated input voltage	24 VDC (20.4 to 28.8 VDC)
	Input conversion range	<ul style="list-style-type: none"> Input range of -10 to 10 V or -5 to 5 V -1% to 101% (full scale) Other input ranges -2% to 102% (full scale) 			Input current	3.5 mA typical (24 VDC)
	Absolute maximum rating	Voltage: ±15 V Input current: ±30 mA			ON voltage/ON current	15 VDC min./3 mA min. (between IOV and each signal)
	Input Impedance	Voltage: 1 MΩ min. Current: 250 Ω			OFF voltage/OFF current	5 VDC max./1 mA max. (between IOV and each signal)
	Resolution	<ul style="list-style-type: none"> Input range of -10 to 10 V or -5 to 5 V 1/64000 (full scale) Other input ranges 1/32000 (full scale) 			ON/OFF response time	1 μs max./1 μs max.
	Over all accuracy	25°C	±0.1% (full scale)		Input filter time	No filter, 4 μs, 8 μs (default), 16 μs, 32 μs, 64 μs, 128 μs, 256 μs
0 to 55°C		±0.2% (full scale)				
Conversion time	5 μs per channel*1					

Dimensions	24 (W) × 100 (H) × 71 (D)	Isolation method	Between the analog input and the NX bus: Power = Transformer, Signal = Digital isolator Between analog inputs: Power = Transformer, Signal = Digital isolator Between the trigger input and the NX bus: Signal = Digital isolator Between the analog input and the trigger input: Power = Transformer, Signal = Digital isolator
Insulation resistance	20 MΩ min. between isolated circuits (at 100 VDC)	Dielectric strength	510 VAC between isolated circuits for 1 minute at a leakage current of 5 mA max.
I/O power supply method	Supply from the NX Bus	Current capacity of I/O power supply terminals	IOV: 0.1 A max. per terminal IOG: 0.1 A max. per terminal
NX Unit power consumption	<ul style="list-style-type: none"> Connected to a CPU Unit 3.30 W max. Connected to a Communications Coupler Unit 2.95 W max. 	Current consumption from I/O power supply	30 mA max.
Weight	140 g max.		

Circuit Configuration	<p>The diagram illustrates the internal circuitry of the unit. On the left, a terminal block provides connections for Input1+ to 4+, SHT1+ to 4+, SHT1- to 4-, Input1- to 4-, IOV1 to 4, IN1 to 4, IOG1 to 4, and I/O power supply + and -. On the right, an NX bus connector provides I/O power supply + and -. The circuit includes an amplifier (AMP) with a 250 Ω resistor and 510 kΩ resistors connected to the input terminals. A current control circuit and an isolation circuit are connected to the IOV and IOG terminals. Internal circuits are connected to the I/O power supply terminals.</p>		
	<p>The following channels are individually isolated.</p> <ul style="list-style-type: none"> Input1+, Input1-, SHT1+, SHT1- Input2+, Input2-, SHT2+, SHT2- Input3+, Input3-, SHT3+, SHT3- Input4+, Input4-, SHT4+, SHT4- 		
Installation orientation and restrictions^{*2}	<p>Installation orientation:</p> <ul style="list-style-type: none"> Connected to a CPU Unit Possible in upright installation. Connected to a Communications Coupler Unit Possible in upright installation. <p>Restrictions: No restrictions</p>		

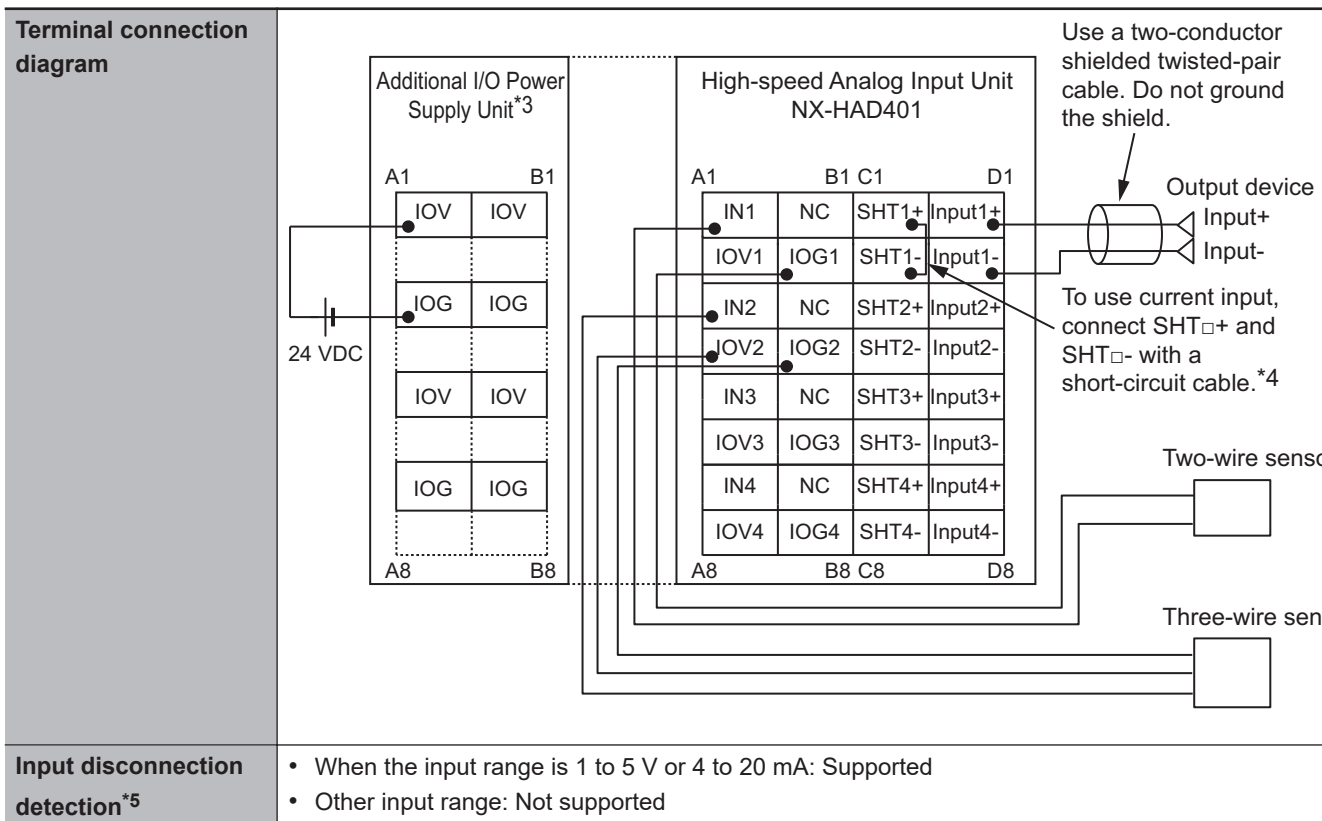

- *1. This is the minimum value. The Units perform conversion in the sampling period determined based on the Number of Samplings Setting. The sampling period must be set to this value or longer.
- *2. The following Unit cannot be connected next to the Unit.
 - Relay Output Unit (NX-OC□□□□)
- *3. Besides the Additional I/O Power Supply Unit, there are Units that can supply I/O power to the NX bus. For example, you can use a Connected Communications Coupler Unit. If you use this Unit to supply I/O power to the High-speed Analog Input Units, the Additional I/O Power Supply Unit is unnecessary. The Additional I/O Power Supply Unit is also unnecessary if you do not use the trigger inputs of the High-speed Analog Input Units.
- *4. Short-circuit cables are not included in the product. The cable length must be 4 cm or less and allow for wiring to the screwless clamping terminal block. Be sure to use cables and ferrules that are applicable to the screwless clamping terminal block.
If the cable is too long, the analog input values may not be accurate.
- *5. To use this function, set the Disconnection Detection Enable/Disable to Enable.

Unit name		High-speed Analog Input Unit	Model	NX-HAD402	
External connection terminals		Screwless clamping terminal block (16 terminals ×2)			
I/O refreshing method		Synchronous I/O refreshing			
Indicators		TS indicator, IN indicator 			
Analog input section	Number of points	4 points	Trigger input section	Number of points	4 points
	Input method	Differential input		Internal I/O common	PNP
	Input range	Voltage: • -10 to 10 V • -5 to 5 V • 0 to 10 V • 0 to 5 V • 1 to 5 V Current: • 0 to 20 mA • 4 to 20 mA		Rated input voltage	24 VDC (20.4 to 28.8 VDC)
	Input conversion range	• Input range of -10 to 10 V or -5 to 5 V -1% to 101% (full scale) • Other input ranges -2% to 102% (full scale)		Input current	3.5 mA typical (24 VDC)
	Absolute maximum rating	Voltage: ±15 V Input current: ±30 mA		ON voltage/ON current	15 VDC min./3 mA min. (between IOG and each signal)
	Input Impedance	Voltage: 1 MΩ min. Current: 250 Ω		OFF voltage/OFF current	5 VDC max./1 mA max. (between IOG and each signal)
	Resolution	• Input range of -10 to 10 V or -5 to 5 V 1/64000 (full scale) • Other input ranges 1/32000 (full scale)		ON/OFF response time	1 μs max./1 μs max.
	Over all ac-cu-racy	25°C		±0.1% (full scale)	Input filter time
0 to 55°C		±0.2% (full scale)			
Conversion time	5 μs per channel*1				

Dimensions	24 (W) × 100 (H) × 71 (D)	Isolation method	Between the analog input and the NX bus: Power = Transformer, Signal = Digital isolator Between analog inputs: Power = Transformer, Signal = Digital isolator Between the trigger input and the NX bus: Signal = Digital isolator Between the analog input and the trigger input: Power = Transformer, Signal = Digital isolator
Insulation resistance	20 MΩ min. between isolated circuits (at 100 VDC)	Dielectric strength	510 VAC between isolated circuits for 1 minute at a leakage current of 5 mA max.
I/O power supply method	Supply from the NX bus	Current capacity of I/O power supply terminals	IOV: 0.1 A max. per terminal IOG: 0.1 A max. per terminal
NX Unit power consumption	<ul style="list-style-type: none"> Connected to a CPU Unit 3.30 W max. Connected to a Communications Coupler Unit 2.95 W max. 	Current consumption from I/O power supply	30 mA max.
Weight	140 g max.		

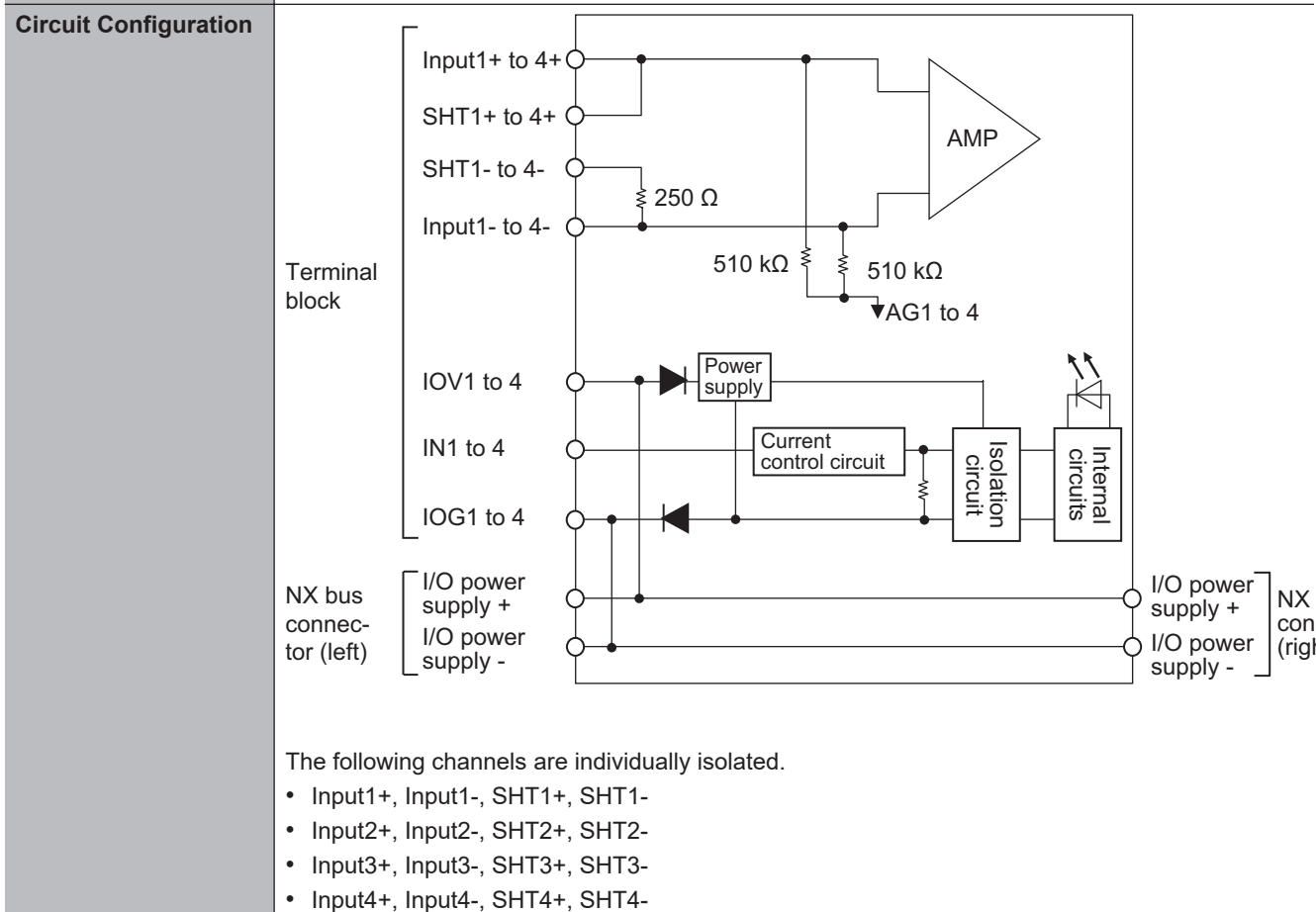

<p>Installation orientation and restrictions^{*2}</p>	<p>Installation orientation:</p> <ul style="list-style-type: none"> • Connected to a CPU Unit Possible in upright installation. • Connected to a Communications Coupler Unit Possible in upright installation. <p>Restrictions: No restrictions</p>
<p>Terminal connection diagram</p>	
<p>Input disconnection detection^{*5}</p>	<ul style="list-style-type: none"> • When the input range is 1 to 5 V or 4 to 20 mA: Supported • Other input range: Not supported

- *1. This is the minimum value. The Units perform conversion in the sampling period determined based on the Number of Samplings Setting. The sampling period must be set to this value or longer.
- *2. The following Unit cannot be connected next to the Unit.
 - Relay Output Unit (NX-OC□□□□)
- *3. Besides the Additional I/O Power Supply Unit, there are Units that can supply I/O power to the NX bus. For example, you can use a Connected Communications Coupler Unit. If you use this Unit to supply I/O power to the High-speed Analog Input Units, the Additional I/O Power Supply Unit is unnecessary. The Additional I/O Power Supply Unit is also unnecessary if you do not use the trigger inputs of the High-speed Analog Input Units.
- *4. Short-circuit cables are not included in the product. The cable length must be 4 cm or less and allow for wiring to the screwless clamping terminal block. Be sure to use cables and ferrules that are applicable to the screwless clamping terminal block.
If the cable is too long, the analog input values may not be accurate.
- *5. To use this function, set the Disconnection Detection Enable/Disable to Enable.

A-2 Dimensions

24 mm Width

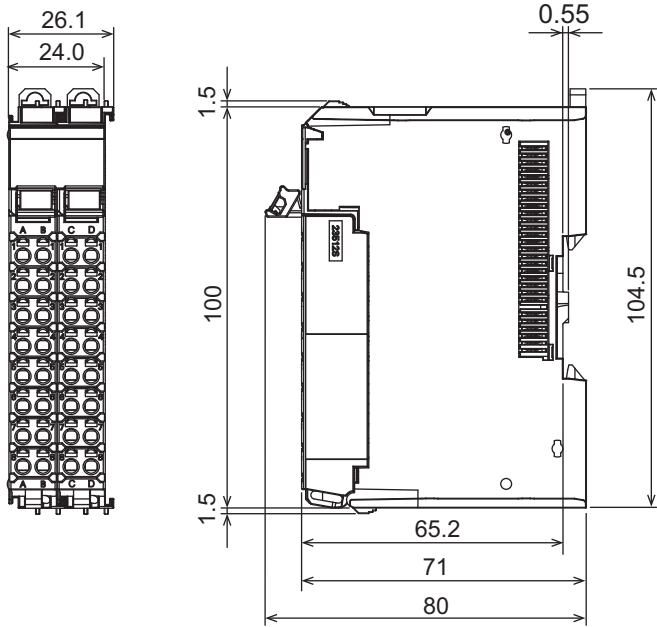

A-2 Dimensions

A

Installation Height

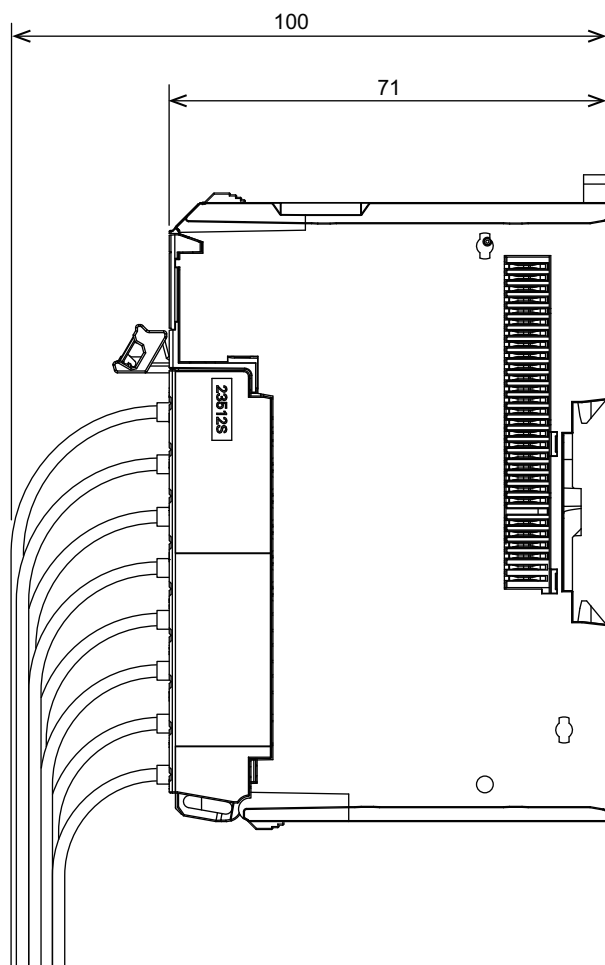

(Unit: mm)

A-3 Programming Examples for Analog Input Data Collection with the Library

The High-speed Analog Input Units read each analog input value that has been sampled in the task periods of the assigned periodic task as more than one I/O data item.

DeviceVariableToArray_100 (Join Device Output Data), a library in the High-speed Analog Inspection Library of Sysmac Library, enables you to join more than one I/O data item into one array variable.

This section shows programming examples that use this library. The system configuration here assumes that the High-speed Analog Input Unit is connected to a CPU Unit. In the programming example where the Unit is connected to an NX-ECC203 EtherCAT Coupler Unit, only differences from the case where it is connected to the CPU Unit are described. Refer to *A-3-3 Connection to the Communications Coupler Unit* on page A-17 for details.

A-3-1 System Configuration

The system configuration is given below.

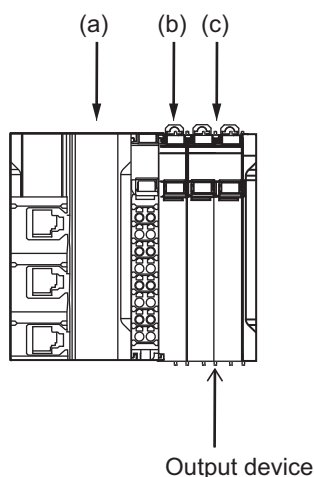

Letter	Description	Model	Description
(a)	NX-series CPU Unit	NX102-□□□□	---
(b)	Additional I/O Power Supply Unit	NX-PF0730	NX Unit number: 1
(c)	High-speed Analog Input Unit	NX-HAD401	<ul style="list-style-type: none"> • NX Unit number: 2 • Channel used: Ch1

A-3-2 Programming Example

The following shows a basic programming example for collecting analog input data by using DeviceVariableToArray_100 (Join Device Output Data), a library in the High-speed Analog Inspection Library of Sysmac Library. Refer to the *Sysmac Library User's Manual for High-speed Analog Inspection Library (Cat. No. W607)* for details on the High-speed Analog Inspection Library of Sysmac Library.

Unit Operation Settings

The following table shows the Unit operation settings for the High-speed Analog Input Units that you set in the program. Use the default values for settings that are not given in the table.

Setting	Set value	Meaning of setting
Ch1 Enable/Disable	TRUE	Ch1 Enable
Ch1 Range Setting	0	-10 to 10 V
Ch1 Number of Samplings Setting	100	100 times

I/O Map

The following table shows the settings of variables that are assigned to the I/O Map on the Sysmac Studio.

I/O port name	Variable name	Description	Data type	Variable type
N2 NX Unit I/O Data Active Status	NXBus_N2_NX_Unit_I_O_Data_Active_Status	NX Unit (Unit2) I/O Data Active	BOOL	Global variable
N2 NX Unit Error Status	NXBus_N2_NX_Unit_Error_Status	NX Unit (Unit2) Error	BOOL	Global variable
Ch1 Number of Samplings	N2_Ch1_Number_of_Samplings	Ch1 Number of Samplings	UINT	Global variable
Ch1 Analog Input Value 1-10	N2_Ch1_Analog_Input_Value_1_10	Ch1 Analog Input Value 1-10	ARRAY[0..9] OF INT	Global variable
Ch1 Analog Input Value 11-20	N2_Ch1_Analog_Input_Value_11_20	Ch1 Analog Input Value 11-20	ARRAY[0..9] OF INT	Global variable
Ch1 Analog Input Value 21-30	N2_Ch1_Analog_Input_Value_21_30	Ch1 Analog Input Value 21-30	ARRAY[0..9] OF INT	Global variable
Ch1 Analog Input Value 31-40	N2_Ch1_Analog_Input_Value_31_40	Ch1 Analog Input Value 31-40	ARRAY[0..9] OF INT	Global variable
Ch1 Analog Input Value 41-50	N2_Ch1_Analog_Input_Value_41_50	Ch1 Analog Input Value 41-50	ARRAY[0..9] OF INT	Global variable
Ch1 Analog Input Value 51-60	N2_Ch1_Analog_Input_Value_51_60	Ch1 Analog Input Value 51-60	ARRAY[0..9] OF INT	Global variable
Ch1 Analog Input Value 61-70	N2_Ch1_Analog_Input_Value_61_70	Ch1 Analog Input Value 61-70	ARRAY[0..9] OF INT	Global variable
Ch1 Analog Input Value 71-80	N2_Ch1_Analog_Input_Value_71_80	Ch1 Analog Input Value 71-80	ARRAY[0..9] OF INT	Global variable
Ch1 Analog Input Value 81-90	N2_Ch1_Analog_Input_Value_81_90	Ch1 Analog Input Value 81-90	ARRAY[0..9] OF INT	Global variable

I/O port name	Variable name	Description	Data type	Variable type
Ch1 Analog Input Value 91-100	N2_Ch1_Analog_Input_Value_91_100	Ch1 Analog Input Value 91-100	ARRAY[0..9] OF INT	Global variable

Variable Table

External variables and internal variables that are used in the programming are given below.

● External Variables

Use the global variables given in the table below as external variables.

Variable name	Data type	Initial value	AT	Retain	Constant	Network publish	Description
NXBus_N2_NX_Unit_I_O_Data_Active_Status	BOOL	FALSE	---	---	---	Do not publish.	NX Unit (Unit2) I/O Data Active
NXBus_N2_NX_Unit_Error_Status	BOOL	FALSE	---	---	---	Do not publish.	NX Unit (Unit2) Error
N2_Ch1_Number_of_Samplings	UINT	---	---	---	---	Do not publish.	Ch1 Number of Samplings
N2_Ch1_Analog_Input_Value_1_10	ARRAY[0..9] OF INT	---	---	---	---	Do not publish.	Ch1 Analog Input Value 1-10
N2_Ch1_Analog_Input_Value_11_20	ARRAY[0..9] OF INT	---	---	---	---	Do not publish.	Ch1 Analog Input Value 11-20
N2_Ch1_Analog_Input_Value_21_30	ARRAY[0..9] OF INT	---	---	---	---	Do not publish.	Ch1 Analog Input Value 21-30
N2_Ch1_Analog_Input_Value_31_40	ARRAY[0..9] OF INT	---	---	---	---	Do not publish.	Ch1 Analog Input Value 31-40
N2_Ch1_Analog_Input_Value_41_50	ARRAY[0..9] OF INT	---	---	---	---	Do not publish.	Ch1 Analog Input Value 41-50
N2_Ch1_Analog_Input_Value_51_60	ARRAY[0..9] OF INT	---	---	---	---	Do not publish.	Ch1 Analog Input Value 51-60
N2_Ch1_Analog_Input_Value_61_70	ARRAY[0..9] OF INT	---	---	---	---	Do not publish.	Ch1 Analog Input Value 61-70
N2_Ch1_Analog_Input_Value_71_80	ARRAY[0..9] OF INT	---	---	---	---	Do not publish.	Ch1 Analog Input Value 71-80
N2_Ch1_Analog_Input_Value_81_90	ARRAY[0..9] OF INT	---	---	---	---	Do not publish.	Ch1 Analog Input Value 81-90
N2_Ch1_Analog_Input_Value_91_100	ARRAY[0..9] OF INT	---	---	---	---	Do not publish.	Ch1 Analog Input Value 91-100

Variable name	Data type	Initial value	AT	Retain	Constant	Network publish	Description
Ch1_Input_Data	AR-RAY[0..9] OF REAL	---	---	---	---	Do not publish.	Ch1 Input Data

● Internal Variables

Variable name	Data type	Initial value	AT	Retain	Constant	Description
I_O_Data_is_Valid	BOOL	FALSE	---	---	---	NX Unit I/O Data Communications Enabled
Ch1_Arrangement_is_Success	BOOL	FALSE	---	---	---	Ch1 Join Successful
Enable_OUT*1	BOOL	FALSE	---	---	---	---

*1. This variable is used only in ST programming.

Ladder Programming

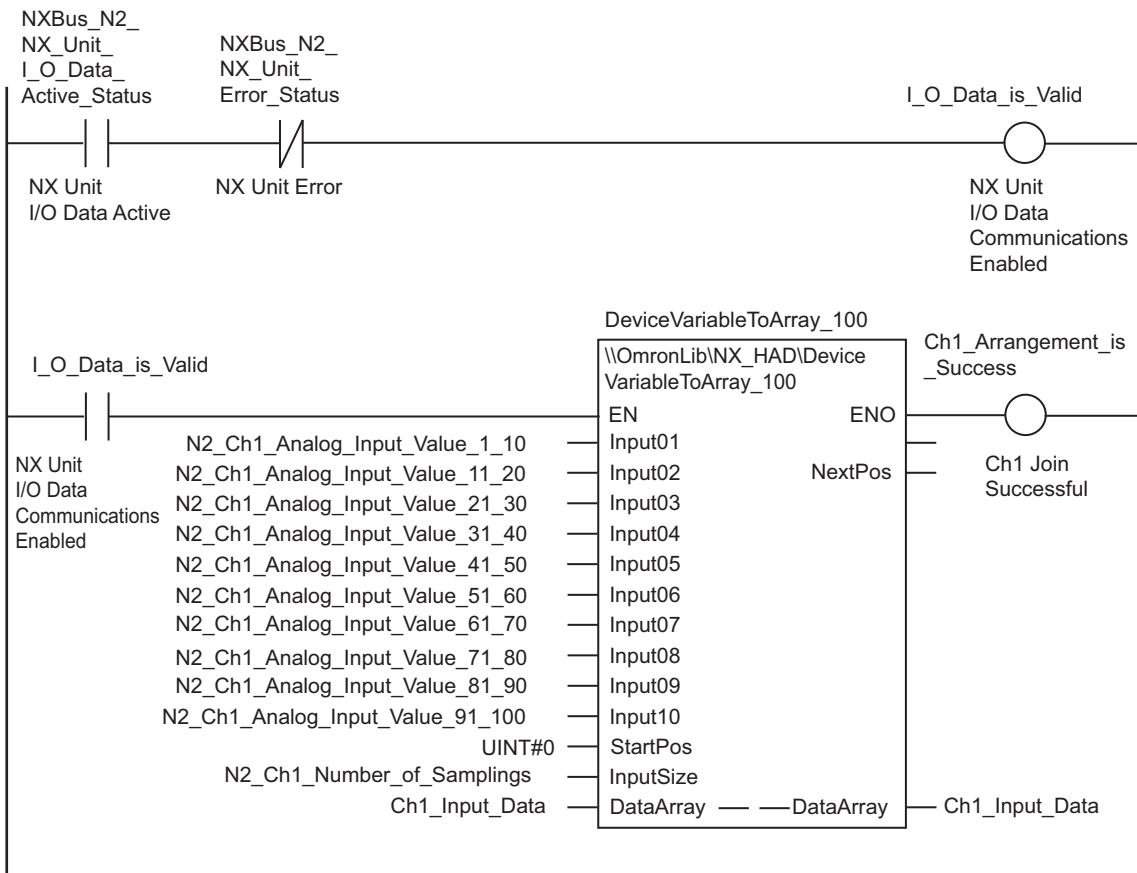

ST Programming

```
//*****
// DeviceVariableToArray_100
```

```

//*****
IF NXBus_N2_NX_Unit_I_O_Data_Active_Status=TRUE AND NXBus_N2_NX_Unit_Error_Status=F
ELSE THEN
    I_O_Data_is_Valid:=TRUE;
ELSE
    I_O_Data_is_Valid:=FALSE;
END_IF;
IF I_O_Data_is_Valid=TRUE THEN
    \OmronLib\NX_HAD\DeviceVariableToArray_100(
        ENO=>Enable_OUT,
        Input01:=N2_Ch1_Analog_Input_Value_1_10,
        Input02:=N2_Ch1_Analog_Input_Value_11_20,
        Input03:=N2_Ch1_Analog_Input_Value_21_30,
        Input04:=N2_Ch1_Analog_Input_Value_31_40,
        Input05:=N2_Ch1_Analog_Input_Value_41_50,
        Input06:=N2_Ch1_Analog_Input_Value_51_60,
        Input07:=N2_Ch1_Analog_Input_Value_61_70,
        Input08:=N2_Ch1_Analog_Input_Value_71_80,
        Input09:=N2_Ch1_Analog_Input_Value_81_90,
        Input10:=N2_Ch1_Analog_Input_Value_91_100,
        StartPos:=UINT#0,
        InputSize:=N2_Ch1_Number_of_Samplings,
        dataArray:=Ch1_Input_Data);
END_IF;
IF Enable_OUT=TRUE THEN
    Ch1_Arrangement_is_Success:=TRUE;
END_IF;

```

A-3-3 Connection to the Communications Coupler Unit

In the programming example where the High-speed Analog Input Unit is connected to an NX-ECC203 EtherCAT Coupler Unit, only differences from the case where it is connected to a CPU Unit are described.

Consider these differences while reading the aforementioned example for connection to the CPU Unit.

System Configuration

The system configuration is given below.

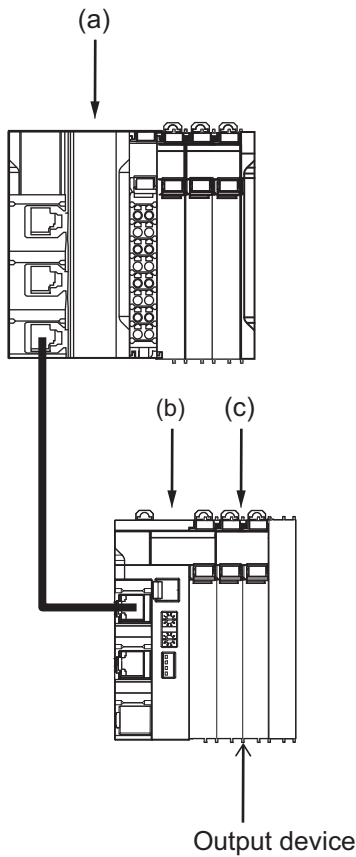

Letter	Description	Model	Description
(a)	NX-series CPU Unit	NX102-□□□□	---
(b)	EtherCAT Coupler Unit	NX-ECC203	Node address: 1
(c)	High-speed Analog Input Unit	NX-HAD401	<ul style="list-style-type: none"> NX Unit number: 1 Channel used: Ch1

Variable Table

External variables and internal variables that are used in the programming are given below.

● External Variables

Use the system-defined variables given in the table below as external variables.

Variable name	Data type	Constant	Description
_EC_PDSlaveTbl[1]	ARRAY[1..192] OF BOOL	<input checked="" type="checkbox"/>	Process Data Communicating Slave Table (Node1)
_EC_CommErrTbl[1]	ARRAY[1..192] OF BOOL	<input checked="" type="checkbox"/>	Communications Error Slave Table (Node1)
_EC_SlaveErrTbl[1]	ARRAY[1..192] OF WORD	<input checked="" type="checkbox"/>	Slave Error Table (Node1)
_EC_InDataInvalid	BOOL	<input checked="" type="checkbox"/>	Input Process Data Invalid Error

● Internal Variables

Variable name	Data type	Initial value	AT	Re-retain	Constant	Description
I_O_Data_is_Valid	BOOL	FALSE	---	---	---	NX Unit I/O Data Communications Enabled
EQ_OUT*1	BOOL	FALSE	---	---	---	---

*1. This variable is used only in ST programming.

Ladder Programming

Change the program as follows when the Unit is connected to an EtherCAT Coupler Unit.

Before change



Change the program as follows.

After change

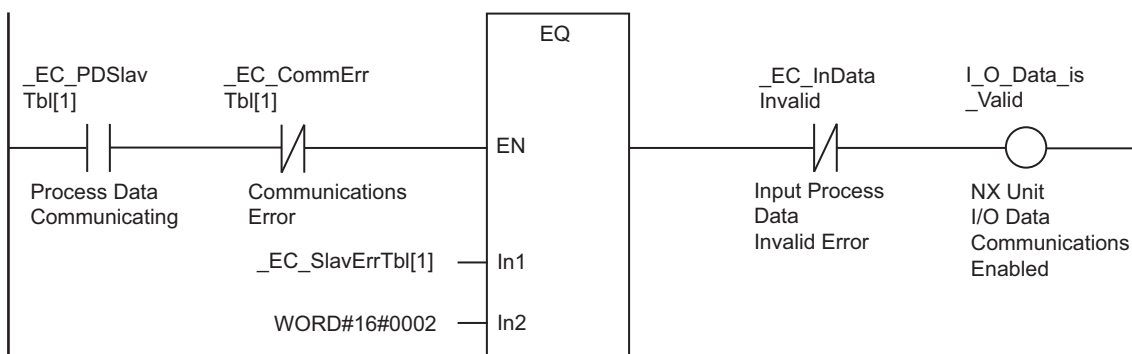

ST Programming

Change the program as follows when the Unit is connected to an EtherCAT Coupler Unit.

Before change

```
IF NXBus_N2_NX_Unit_I_O_Data_Active_Status=TRUE AND NXBus_N2_NX_Unit_Error_Status=F
  ELSE THEN
```

```

        I_O_Data_is_Valid:=TRUE;
ELSE
        I_O_Data_is_Valid:=FALSE;
END_IF;

```

Change the program as follows.

After change

```

IF _EC_PDslavTbl[1]=TRUE AND _EC_CommErrTbl[1]=FALSE AND _EC_SlavErrTbl[1]=WORD#16#
0002 THEN
        EQ_OUT:=TRUE;
ELSE
        EQ_OUT:=FALSE;
END_IF;

IF EQ_OUT =TRUE AND _EC_InDataInvalid=FALSE THEN
        I_O_Data_is_Valid:=TRUE;
ELSE
        I_O_Data_is_Valid:=FALSE;
END_IF;

```

A-4 Digital Filter Design with the Library

This section shows digital filter design examples that utilize the following libraries in the High-speed Analog Inspection Library of Sysmac Library.

- DeviceVariableToArray_100 (Join Device Output Data)
- DataRecorder (Data Recorder)
- LogDataToCSV (Write Log Data to CSV File)

These libraries enable you to output the analog input values that have been read by a High-speed Analog Input Unit to a CSV file. By converting the output data in the form of a CSV file into a graph, you can adjust the digital filter parameters of the High-speed Analog Input Unit and check their effects.

This section describes the system configuration, and shows how to design digital filters and their programming examples. The system configuration here assumes that the High-speed Analog Input Unit is connected to a CPU Unit. In the programming example where the Unit is connected to an NX-ECC203 EtherCAT Coupler Unit, only differences from the case where it is connected to the CPU Unit are described. Refer to *A-4-4 Connection to the Communications Coupler Unit* on page A-34 for details.

A-4-1 System Configuration

The system configuration is given below.

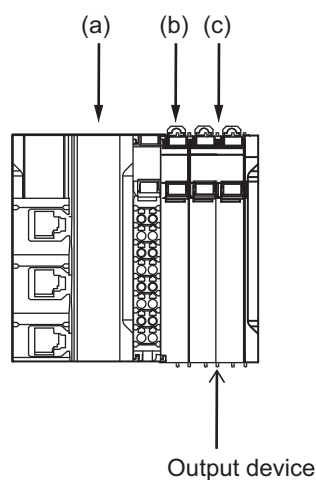

Letter	Description	Model	Description
(a)	NX-series CPU Unit	NX102-□□□□	---
(b)	Additional I/O Power Supply Unit	NX-PF0730	NX Unit number: 1
(c)	High-speed Analog Input Unit	NX-HAD401	<ul style="list-style-type: none"> • NX Unit number: 2 • Channel used: Ch1

A-4-2 Digital Filter Design Examples

The functions used for designing digital filters and the design procedure are shown below.

Functions To Use

The following functions are used in the design examples.

- High-speed Analog Inspection Library of Sysmac Library
DeviceVariableToArray_100 (Join Device Output Data)
DataRecorder (Data Recorder)
LogDataToCSV (Write Log Data to CSV File)

- Moving average filter of digital filtering

In this example, the moving average filter is used to attenuate the signals in the specific frequency because the effect of periodic noise is assumed.

Refer to *Moving Average Filter* on page 8-23 for information on the moving average filter.



Additional Information

Use the digital low-pass filter to stabilize analog input values if measurement values are unstable due to the effects of non-periodic noise. In digital low-pass filtering, the smaller the cutoff frequency is, the wider range of noise you can remove. This stabilizes the analog input values, but causes the step response time to increase. Set the value of the cutoff frequency after you consider the requirements of the response time. Refer to *Digital Low-pass Filter* on page 8-20 for information on the digital low-pass filter.

Digital Filter Setting Procedure

The following gives an example procedure for designing digital filters.

- 1 Execute the program that uses the High-speed Analog Inspection Library of Sysmac Library and export the log data to a CSV file.
Refer to *A-4-3 Programming Example* on page A-25 for a programming example.
- 2 Open the exported CSV file in Microsoft Excel, and then create a broken line graph with the axis specifications below.

Item	Specification
Vertical axis	Ch1 Analog Input Value
Horizontal axis	Number of data items

Adjust the display range of the vertical axis and horizontal axis so that you can analyze the fluctuation frequency of the Ch1 Analog Input Value.

The following gives the CSV file format and data layout.

	A	B
1	StartDateTime	2018-01-23-18:32:43.853000000
2	EndDateTime	2018-01-23-18:32:43.972000000
3	TriggerDateTime	2018-01-23-18:32:43.853000000
4	RecordNum	12000
5	TriggerPos	0
6	TimeStamp	Data
7	1.07479E+11	9857
8	1.07479E+11	9823
9	1.07479E+11	9790
10	1.07479E+11	9760
11	1.07479E+11	9725
12	1.07479E+11	9693
13	1.07479E+11	9662
14	1.07479E+11	9630
15	1.07479E+11	9591
16	1.07479E+11	9566

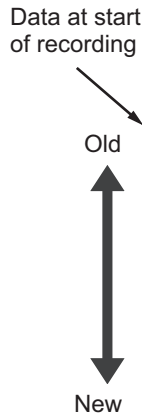

- Column A shows the Analog Input Time Stamps.
- Column B shows the Analog Input Values.
- Row 7 shows the data at the start of recording. The larger the row number, the newer the data.

3 Calculate the fluctuation frequency that is contained in the Ch1 Analog Input Value from the broken line graph.

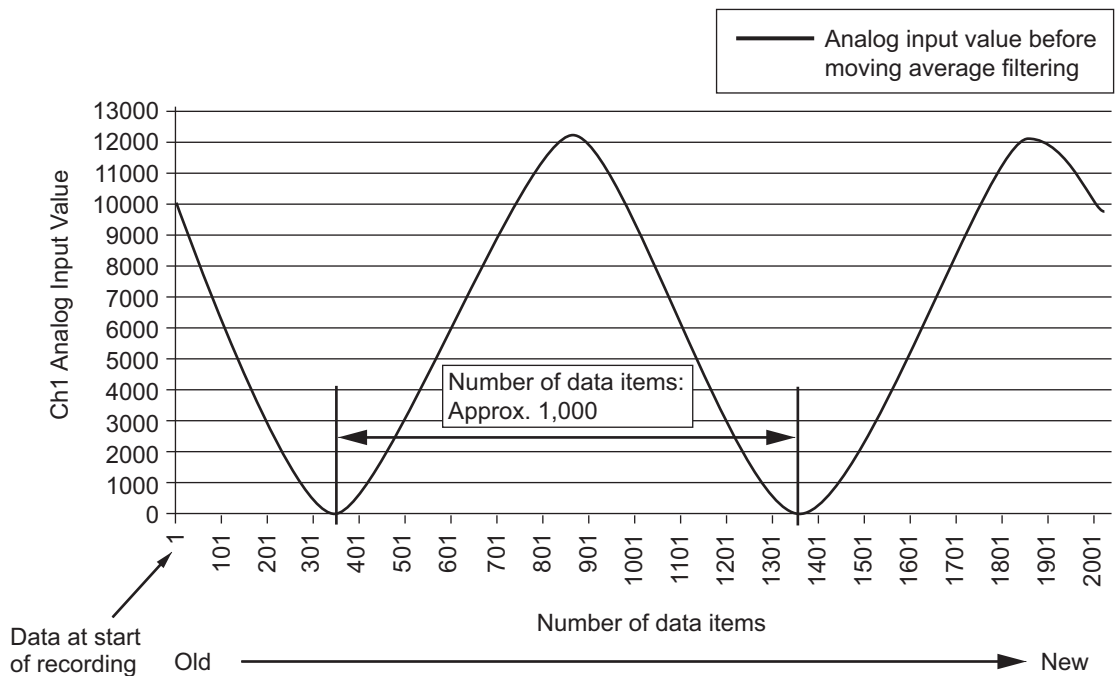

Use the following formula to calculate the fluctuation frequency of the Ch1 Analog Input Value.

$$\text{Fluctuation frequency} = \frac{1}{\text{Fluctuation period}} = \frac{1}{\text{Number of data items} \times \text{Data sampling period}}$$

According to the graph, the number of data items for one fluctuation period is approximately 1,000. When the task period of the assigned periodic task is 1 ms and the number of samplings is 100, the data sampling period is 10 μs. If the fluctuation frequency of the Ch1 Analog Input Value is calculated, it will be as follows.

$$\text{Fluctuation frequency} = \frac{1}{\text{Fluctuation period}} = \frac{1}{1,000 \times 10 [\mu\text{s}]} = 100 [\text{Hz}]$$

- 4** Calculate the set value of moving average count for the moving average filter that attenuates the signal of the fluctuation frequency.

Use the following formula to calculate the set value of moving average count.

$$\text{Set value of moving average count} = \frac{(1 \div \text{Digital Filter Processing Period} [\mu\text{s}]) \times 1,000,000 [\text{Hz}]}{f_N [\text{Hz}]}$$

Refer to *Digital Filter Processing Period* on page 8-19 for information on the Digital Filter Processing Period.

When the sampling period is 10 μs, the Digital Filter Processing Period is 5 μs. The fluctuation frequency is the value calculated in step 3. If the moving average count is calculated, it will be as follows.

$$\begin{aligned} \text{Set value of moving average count} &= \frac{(1 \div \text{Digital Filter Processing Period} [\mu\text{s}]) \times 1,000,000 [\text{Hz}]}{f_N [\text{Hz}]} \\ &= \frac{(1 \div 5 [\mu\text{s}]) \times 1,000,000 [\text{Hz}]}{100 [\text{Hz}]} \\ &= 2,000 [\text{times}] \end{aligned}$$

- 5** Set the moving average count for the Ch1 Moving Average Filter 1 to 2,000 times. Refer to *8-5-3 Setting Method* on page 8-27 for how to set the moving average count.
- 6** Execute the program that use the High-speed Analog Inspection Library of Sysmac Library and export the log data to a CSV file to check the effectiveness of the Ch1 Moving Average Filter 1.
- 7** Open the exported CSV file in Microsoft Excel, and then create a broken line graph with the specifications below.

Item	Specification
Vertical axis	Analog input value after filtering
Horizontal axis	Number of data items

Set the same display range for the vertical axis and the horizontal axis as step 2.

- 8** Check the effectiveness of the Ch1 Moving Average Filter 1 on the broken line graph.

Fluctuations in the measurement values are significantly suppressed by the Ch1 Moving Average Filter 1.

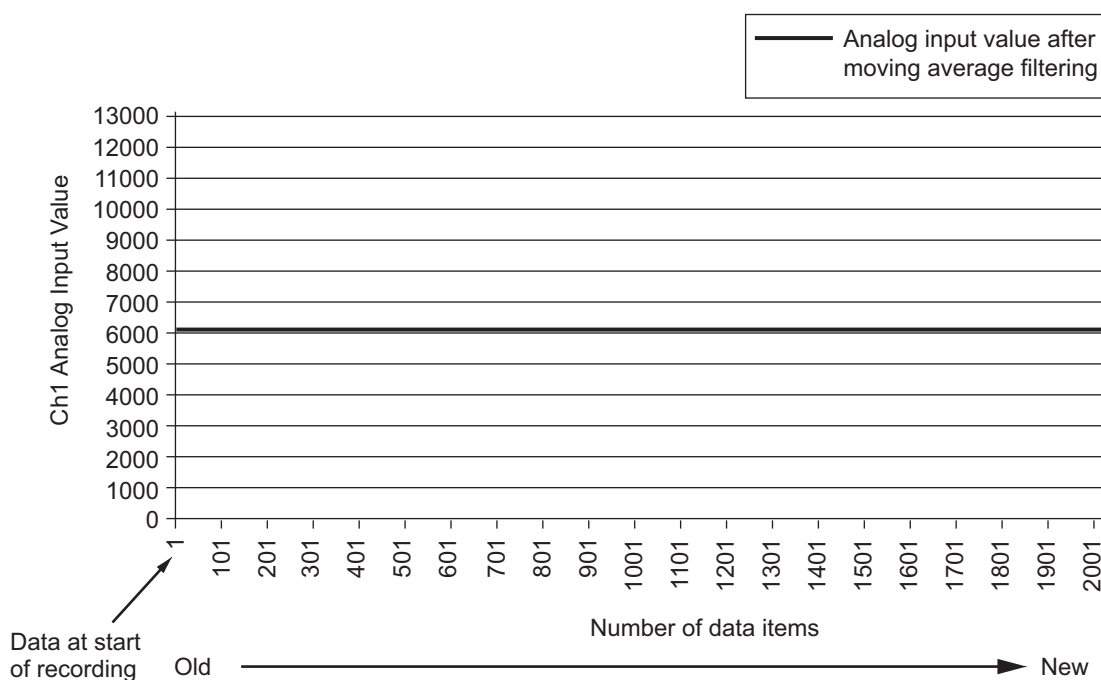

Additional Information

In this example, fluctuations are significantly suppressed using only the Ch1 Moving Average Filter 1. If you cannot suppress frequency fluctuations from a noise component only with the Ch1 Moving Average Filter 1, use the Ch1 Moving Average Filter 2 together to suppress the fluctuations. At this time, design the Ch1 Moving Average Filter 2 with the same design procedure and same requirements as the Ch1 Moving Average Filter 1 after you design the Ch1 Moving Average Filter 1.

A-4-3 Programming Example

This section shows programming examples that use the following libraries in the High-speed Analog Inspection Library of Sysmac Library.

- DeviceVariableToArray_100 (Join Device Output Data)
- DataRecorder (Data Recorder)
- LogDataToCSV (Write Log Data to CSV File)

Refer to the *Sysmac Library User's Manual for High-speed Analog Inspection Library (Cat. No. W607)* for details on the High-speed Analog Inspection Library of Sysmac Library.

In the following programming examples, you collect analog input values of Ch1 and then export the collected data to a CSV file.

Unit Operation Settings

The following table shows the Unit operation settings for the High-speed Analog Input Unit that you set in the program. Use the default values for settings that are not given in the table.

Setting	Set value	Meaning of setting
Ch1 Enable/Disable	TRUE	Ch1 Enable
Ch1 Range Setting	0	-10 to 10 V
Ch1 Number of Samplings Setting	100	100 times
Ch1 Filter 1 Moving Average Count	0	Ch1 Moving Average Filter 1 disabled
Ch1 Filter 2 Moving Average Count	0	Ch1 Moving Average Filter 2 disabled

Task Settings

The following table shows the task settings.

Task type	Task name	Period	Program to be assigned
Priority-4 primary periodic task	PrimaryTask	1 ms	Assign a program that uses the following libraries: <ul style="list-style-type: none"> DeviceVariableToArray_100 (Join Device Output Data) DataRecorder (Data Recorder)
Priority-17 periodic task	PeriodicTask0	10 ms	To reduce the possibility of a Task Period Exceeded error, assign a program that uses the following library. <ul style="list-style-type: none"> LogDataToCSV (Write Log Data to CSV File)

The following table shows the task settings for controlling I/O.

Unit position	Unit	Task name
NXBusMaster	NX Bus Master	---
Unit1	NX-PF0730	PrimaryTask
Unit2	NX-HAD401	PrimaryTask

I/O Map

The following table shows the settings of variables that are assigned to the I/O Map on the Sysmac Studio.

I/O port name	Variable name	Description	Data type	Variable type
N2 NX Unit I/O Data Active Status	NXBus_N2_NX_Unit_I_O_Data_Active_Status	NX Unit (Unit2) I/O Data Active	BOOL	Global variable
N2 NX Unit Error Status	NXBus_N2_NX_Unit_Error_Status	NX Unit (Unit2) Error	BOOL	Global variable
Analog Input Time Stamp	N2_Analog_Input_Time_Stamp	Analog Input Time Stamp	ULINT	Global variable
Ch1 Number of Samplings	N2_Ch1_Number_of_Samplings	Ch1 Number of Samplings	UINT	Global variable
Ch1 Analog Input Value 1-10	N2_Ch1_Analog_Input_Value_1_10	Ch1 Analog Input Value 1-10	ARRAY[0..9] OF INT	Global variable
Ch1 Analog Input Value 11-20	N2_Ch1_Analog_Input_Value_11_20	Ch1 Analog Input Value 11-20	ARRAY[0..9] OF INT	Global variable

I/O port name	Variable name	Description	Data type	Variable type
Ch1 Analog Input Value 21-30	N2_Ch1_Analog_Input_Value_21_30	Ch1 Analog Input Value 21-30	ARRAY[0..9] OF INT	Global variable
Ch1 Analog Input Value 31-40	N2_Ch1_Analog_Input_Value_31_40	Ch1 Analog Input Value 31-40	ARRAY[0..9] OF INT	Global variable
Ch1 Analog Input Value 41-50	N2_Ch1_Analog_Input_Value_41_50	Ch1 Analog Input Value 41-50	ARRAY[0..9] OF INT	Global variable
Ch1 Analog Input Value 51-60	N2_Ch1_Analog_Input_Value_51_60	Ch1 Analog Input Value 51-60	ARRAY[0..9] OF INT	Global variable
Ch1 Analog Input Value 61-70	N2_Ch1_Analog_Input_Value_61_70	Ch1 Analog Input Value 61-70	ARRAY[0..9] OF INT	Global variable
Ch1 Analog Input Value 71-80	N2_Ch1_Analog_Input_Value_71_80	Ch1 Analog Input Value 71-80	ARRAY[0..9] OF INT	Global variable
Ch1 Analog Input Value 81-90	N2_Ch1_Analog_Input_Value_81_90	Ch1 Analog Input Value 81-90	ARRAY[0..9] OF INT	Global variable
Ch1 Analog Input Value 91-100	N2_Ch1_Analog_Input_Value_91_100	Ch1 Analog Input Value 91-100	ARRAY[0..9] OF INT	Global variable

Variable Table

External variables and internal variables that are used in the programming are given below.

● External Variables

Use the global variables given in the table below as external variables.

Variable name	Data type	Initial value	AT	Re-tain	Con-stant	Network publish	Description
NXBus_N2_NX_Unit_I_O_Data_Active_Status	BOOL	FALSE	---	---	---	Do not publish.	NX Unit (Unit2) I/O Data Active
NXBus_N2_NX_Unit_Error_Status	BOOL	FALSE	---	---	---	Do not publish.	NX Unit (Unit2) Error
N2_Analog_Input_Time_Stamp	ULINT	---	---	---	---	Do not publish.	Analog Input Time Stamp
N2_Ch1_Number_of_Samplings	UINT	---	---	---	---	Do not publish.	Ch1 Number of Samplings
N2_Ch1_Analog_Input_Value_1_10	ARRAY[0..9] OF INT	---	---	---	---	Do not publish.	Ch1 Analog Input Value 1-10
N2_Ch1_Analog_Input_Value_11_20	ARRAY[0..9] OF INT	---	---	---	---	Do not publish.	Ch1 Analog Input Value 11-20

Variable name	Data type	Initial value	AT	Re-retain	Constant	Network publish	Description
N2_Ch1_Analog_Input_Value_21_30	ARRAY[0..9] OF INT	---	---	---	---	Do not publish.	Ch1 Analog Input Value 21-30
N2_Ch1_Analog_Input_Value_31_40	ARRAY[0..9] OF INT	---	---	---	---	Do not publish.	Ch1 Analog Input Value 31-40
N2_Ch1_Analog_Input_Value_41_50	ARRAY[0..9] OF INT	---	---	---	---	Do not publish.	Ch1 Analog Input Value 41-50
N2_Ch1_Analog_Input_Value_51_60	ARRAY[0..9] OF INT	---	---	---	---	Do not publish.	Ch1 Analog Input Value 51-60
N2_Ch1_Analog_Input_Value_61_70	ARRAY[0..9] OF INT	---	---	---	---	Do not publish.	Ch1 Analog Input Value 61-70
N2_Ch1_Analog_Input_Value_71_80	ARRAY[0..9] OF INT	---	---	---	---	Do not publish.	Ch1 Analog Input Value 71-80
N2_Ch1_Analog_Input_Value_81_90	ARRAY[0..9] OF INT	---	---	---	---	Do not publish.	Ch1 Analog Input Value 81-90
N2_Ch1_Analog_Input_Value_91_100	ARRAY[0..9] OF INT	---	---	---	---	Do not publish.	Ch1 Analog Input Value 91-100
Ch1_Input_Data	ARRAY[0..99] OF REAL	---	---	---	---	Do not publish.	Ch1 Input Data
Ch1_Log_Data	ARRAY[0..11999] OF OmronLib\DataRecorder\Log-Data	---	---	---	---	Do not publish.	Ch1 Log Data
Ch1_Data_Buf	ARRAY[0..11999] OF OmronLib\DataRecorder\Log-Data	---	---	---	---	Do not publish.	Ch1 Input Buffer
Ch1_Rec_Info	OmronLib\DataRecorder\RecordInfo	---	---	---	---	Do not publish.	Ch1 Record Information
Rec_is_End	BOOL	FALSE	---	---	---	Do not publish.	Recording Ended

● Internal Variables

Variable name	Data type	Initial value	AT	Re-retain	Constant	Description
I_O_Data_is_Valid	BOOL	FALSE	---	---	---	NX Unit I/O Data Communications Enabled
Ch1_Arrangement_is_Success	BOOL	FALSE	---	---	---	Ch1 Join Successful
Enable_OUT*1	BOOL	FALSE	---	---	---	---

Variable name	Data type	Initial value	AT	Retain	Constant	Description
DataRecorder_instance	OmronLib \DataRecorder\DataRecorder	---	---	---	---	Data Recorder
Start	BOOL	FALSE	---	---	---	Start
Rec_is_Start	BOOL	FALSE	---	---	---	Recording Started
Trig_Rdy	BOOL	FALSE	---	---	---	Trigger Input Ready
Ch1_Trig_Input	BOOL	FALSE	---	---	---	Ch1 Trigger Input
Ch1_Rec_End	BOOL	FALSE	---	---	---	Ch1 Recording Ended
Enable*1	BOOL	FALSE	---	---	---	---
LogDataToCSV_instance	OmronLib \DataRecorder \LogDataToCSV	---	---	---	---	Write Log Data to CSV File
CSV_Output_is_Start	BOOL	FALSE	---	---	---	CSV Output Started
CSV_Output_is_Done	BOOL	FALSE	---	---	---	CSV Output Done
Execute*1	BOOL	FALSE	---	---	---	---
Done*1	BOOL	FALSE	---	---	---	---

*1. This variable is used only in ST programming.

Ladder Programming

● Programming Examples That Use DeviceVariableToArray_100 and DataRecorder

The following shows programming examples that use DeviceVariableToArray_100 (Join Device Output Data) and DataRecorder (Data Recorder). Assign the programs to the priority-4 primary periodic task.

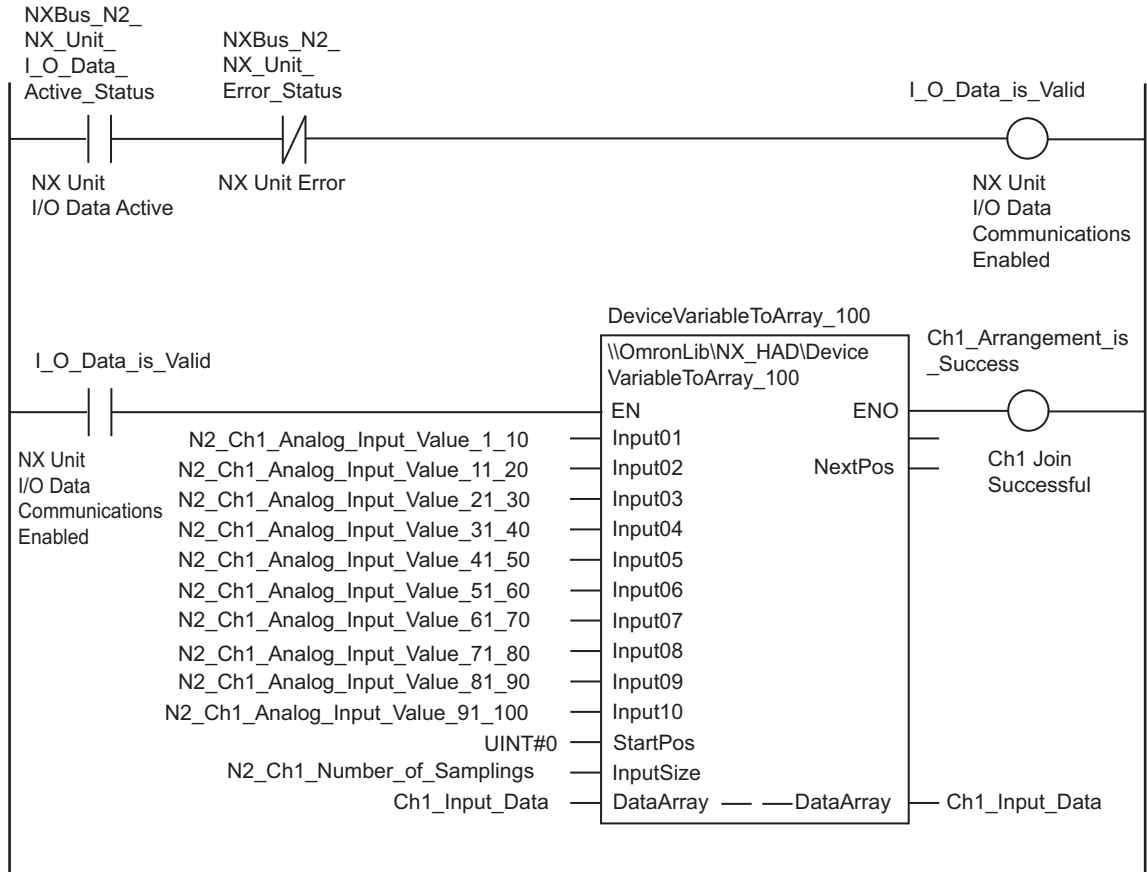

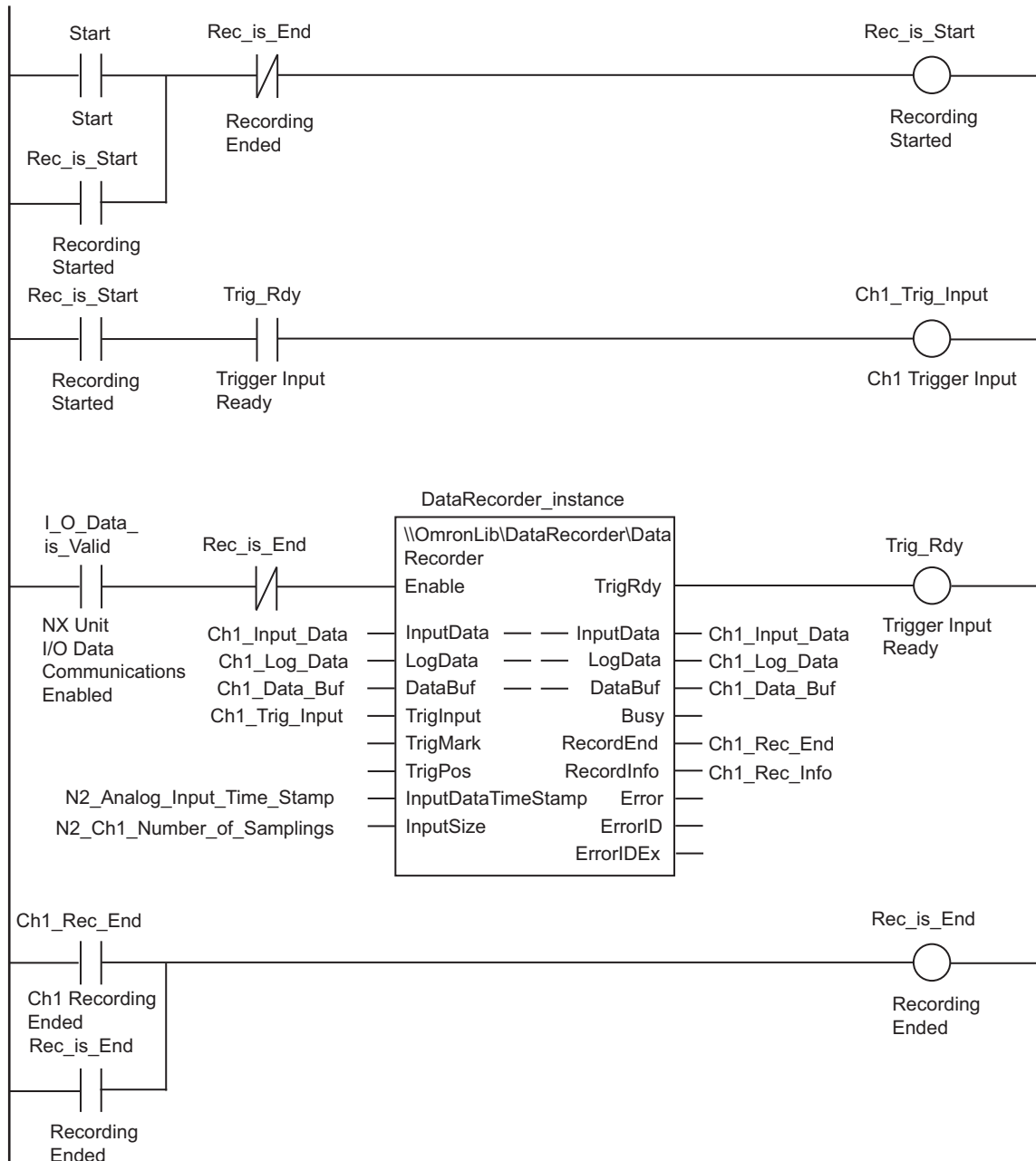

● **Programming Example That Uses LogDataToCSV**

The following shows a programming example that uses LogDataToCSV (Write Log Data to CSV File). Assign this program to the priority-17 periodic task.

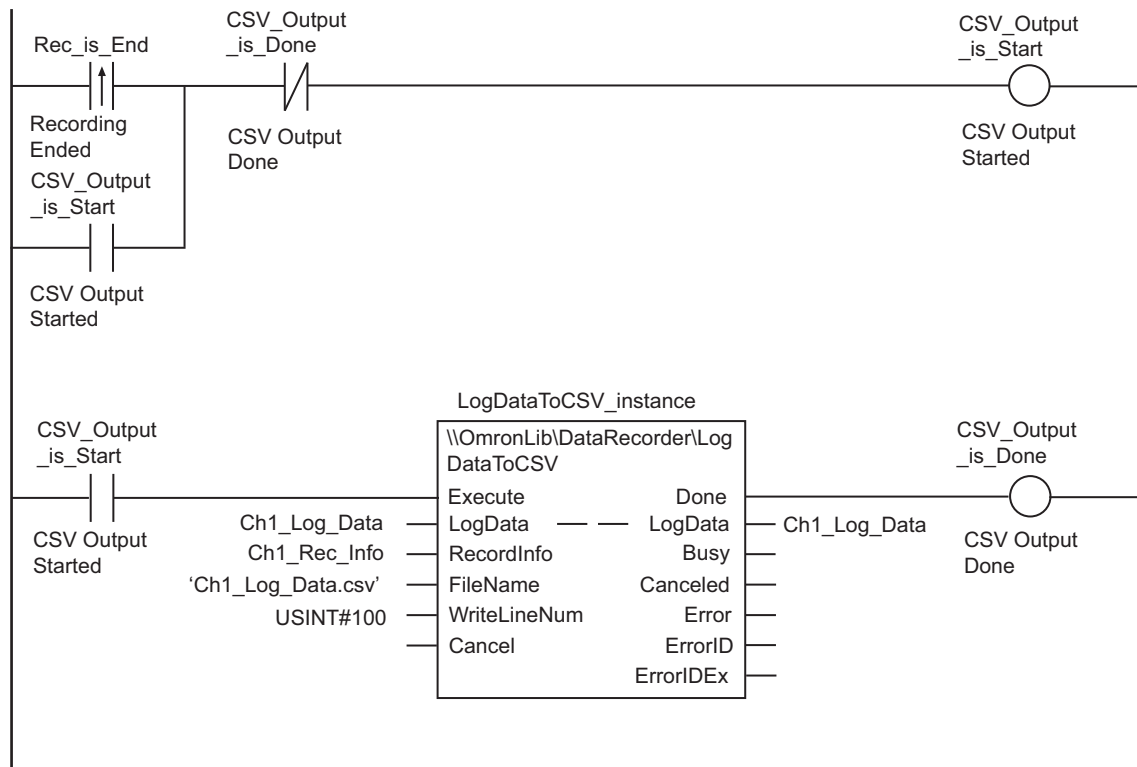

ST Programming

● Programming Examples That Use DeviceVariableToArray_100 and DataRecorder

The following shows programming examples that use DeviceVariableToArray_100 (Join Device Output Data) and DataRecorder (Data Recorder). Assign the programs to the priority-4 primary periodic task.

```

//*****
// DeviceVariableToArray_100
//*****
IF NXBus_N2_NX_Unit_I_O_Data_Active_Status=TRUE AND NXBus_N2_NX_Unit_Error_Status
=FALSE THEN
    I_O_Data_is_Valid:=TRUE;
ELSE
    I_O_Data_is_Valid:=FALSE;
END_IF;
IF I_O_Data_is_Valid=TRUE THEN
    \\OmronLib\NX_HAD\DeviceVariableToArray_100(
        ENO=>Enable_OUT,
        Input01:=N2_Ch1_Analog_Input_Value_1_10,
        Input02:=N2_Ch1_Analog_Input_Value_11_20,
        Input03:=N2_Ch1_Analog_Input_Value_21_30,
        Input04:=N2_Ch1_Analog_Input_Value_31_40,
        Input05:=N2_Ch1_Analog_Input_Value_41_50,

```

```

        Input06:=N2_Ch1_Analog_Input_Value_51_60,
        Input07:=N2_Ch1_Analog_Input_Value_61_70,
        Input08:=N2_Ch1_Analog_Input_Value_71_80,
        Input09:=N2_Ch1_Analog_Input_Value_81_90,
        Input10:=N2_Ch1_Analog_Input_Value_91_100,
        StartPos:=UINT#0,
        InputSize:=N2_Ch1_Number_of_Samplings,
        dataArray:=Ch1_Input_Data);
END_IF;
IF Enable_OUT=TRUE THEN
    Ch1_Arrangement_is_Success:=TRUE;
END_IF;

//*****
//  DataRecorder
//*****
IF Start=TRUE AND Rec_is_End=FALSE THEN
    Rec_is_Start:=TRUE;
    Enable:=TRUE;
END_IF;

IF Rec_is_Start=TRUE AND Trig_Rdy=TRUE THEN
    Ch1_Trig_Input:=TRUE;
END_IF;

IF I_O_Data_is_Valid=TRUE AND Rec_is_End=FALSE THEN
    DataRecorder_instance(Enable:=Enable,
        InputData:=Ch1_Input_Data,
        LogData:=Ch1_Log_Data,
        DataBuf:=Ch1_Data_Buf,
        TrigInput:=Ch1_Trig_Input,
        InputDataTimeStamp:=N2_Analog_Input_Time_Stamp,
        InputSize:=N2_Ch1_Number_of_Samplings,
        TrigRdy=>Trig_Rdy,
        RecordEnd=>Ch1_Rec_End,
        RecordInfo=>Ch1_Rec_Info);
END_IF;

IF Ch1_Rec_End=TRUE THEN
    Rec_is_End:=TRUE;
    Enable:=FALSE;
End_IF;

```

● Programming Example That Uses LogDataToCSV

The following shows a programming example that uses LogDataToCSV (Write Log Data to CSV File). Assign this program to the priority-17 periodic task.

```

//*****
//  LogDataToCSV
//*****
IF Rec_is_End=TRUE AND CSV_Output_is_Done=FALSE THEN
    CSV_Output_is_Start:=TRUE;
    Rec_is_End:=FALSE;
    Execute:=TRUE;
END_IF;

IF CSV_Output_is_Start=TRUE THEN
    LogDataToCSV_instance (Execute:=Execute,
        LogData:=Ch1_Log_Data,
        RecordInfo:=Ch1_Rec_Info,
        FileName:='Ch1_Log_Data.csv',
        WriteLineNum:=USINT#100,
        Done=>Done);
END_IF;

IF Done=TRUE THEN
    CSV_Output_is_Done:=TRUE;
    Execute:=FALSE;
END_IF;

```

A-4-4 Connection to the Communications Coupler Unit

In the programming example where the High-speed Analog Input Unit is connected to an NX-ECC203 EtherCAT Coupler Unit, only differences from the case where it is connected to a CPU Unit are described.

Consider these differences while reading the aforementioned example for connection to the CPU Unit.

System Configuration

The system configuration is given below.

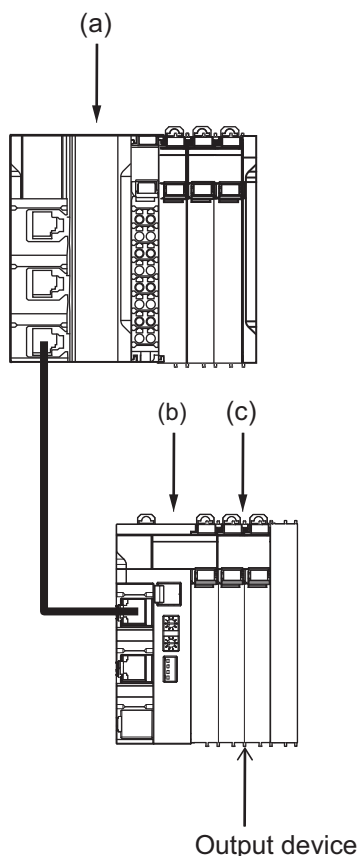

Letter	Description	Model	Description
(a)	NX-series CPU Unit	NX102-□□□□	---
(b)	EtherCAT Coupler Unit	NX-ECC203	Node address: 1
(c)	High-speed Analog Input Unit	NX-HAD401	<ul style="list-style-type: none"> • NX Unit number: 1 • Channel used: Ch1

Variable Table

External variables and internal variables that are used in the programming are given below.

● External Variables

Use the system-defined variables given in the table below as external variables.

Variable name	Data type	Constant	Description
_EC_PDslavTbl[1]	ARRAY[1..192] OF BOOL	<input checked="" type="checkbox"/>	Process Data Communicating Slave Table (Node1)
_EC_CommErrTbl[1]	ARRAY[1..192] OF BOOL	<input checked="" type="checkbox"/>	Communications Error Slave Table (Node1)
_EC_SlavErrTbl[1]	ARRAY[1..192] OF WORD	<input checked="" type="checkbox"/>	Slave Error Table (Node1)
_EC_InDataInvalid	BOOL	<input checked="" type="checkbox"/>	Input Process Data Invalid Error

● Internal Variables

Variable name	Data type	Initial value	AT	Re-tain	Constant	Description
I_O_Data_is_Valid	BOOL	FALSE	---	---	---	NX Unit I/O Data Communications Enabled
EQ_OUT*1	BOOL	FALSE	---	---	---	---

*1. This variable is used only in ST programming.

Ladder Programming

Change the program as follows when the Unit is connected to an EtherCAT Coupler Unit.

Before change



Change the program as follows.

After change

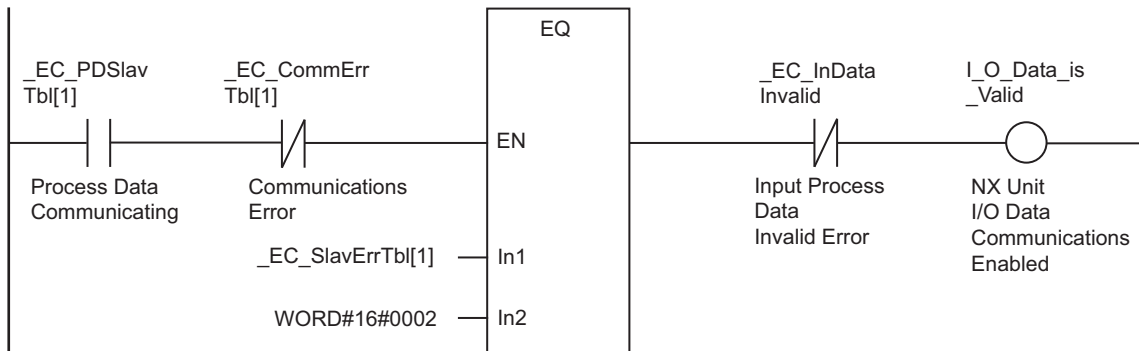

ST Programming

Change the program as follows when the Unit is connected to an EtherCAT Coupler Unit.

Before change

```
IF NXBus_N2_NX_Unit_I_O_Data_Active_Status=TRUE AND NXBus_N2_NX_Unit_Error_Status=F
  ELSE THEN
```



```
    I_O_Data_is_Valid:=TRUE;  
ELSE  
    I_O_Data_is_Valid:=FALSE;  
END_IF;
```

Change the program as follows.

After change

```
IF _EC_PDslavTbl[1]=TRUE AND _EC_CommErrTbl[1]=FALSE AND _EC_SlavErrTbl[1]=WORD#16#  
0002 THEN  
    EQ_OUT:=TRUE;  
ELSE  
    EQ_OUT:=FALSE;  
END_IF;  
  
IF EQ_OUT =TRUE AND _EC_InDataInvalid=FALSE THEN  
    I_O_Data_is_Valid:=TRUE;  
ELSE  
    I_O_Data_is_Valid:=FALSE;  
END_IF;
```

A-5 List of NX Objects

This section explains the NX objects of the High-speed Analog Input Units.

The method to access NX objects through instructions or other messages depends on where the NX Unit is connected.

If the NX Unit is connected to a CPU Unit, access is possible with the Read NX Unit Object instruction and the Write NX Unit Object instruction.

When the NX Unit is connected to a Communications Coupler Unit, the method depends on the connected communications master and Communications Coupler Unit.

Refer to the user's manual for the connected Communications Coupler Unit for method to use messages to access NX objects on Slave Terminals.

A-5-1 Format of NX Object Descriptions

In this manual, NX objects are described with the following format.

Index (hex)	Subindex (hex)	Object name	Default value	Data range	Unit	Data type	Access	I/O allocation	Data attribute
-------------	----------------	-------------	---------------	------------	------	-----------	--------	----------------	----------------

- Index (hex) : This is the index of the NX object that is expressed as a four-digit hexadecimal number.
- Subindex (hex) : This is the subindex of the NX object that is expressed as a two-digit hexadecimal number.
- Object name : This is the name of the object. For a subindex, this is the name of the subindex.
- Default value : This is the value that is set by default.
- Data range : For a read-only (RO) NX object, this is the range of the data you can read. For a read-write (RW) NX object, this is the setting range of the data.
- Unit : The unit is the physical units.
- Data type : This is the data type of the object.
- Access : This data tells if the object is read-only or read/write.
RO: Read only
RW: Read/write
- I/O allocation : This tells whether I/O allocation is allowed.
- Data attribute : This is the timing when changes to writable NX objects are enabled.
Y: Enabled by restarting
N: Enabled at all times
---: Write-prohibited

A-5-2 Unit Information Objects

The following objects are related to the product information.

Index (hex)	Subindex (hex)	Object name	Default value	Data range	Unit	Data type	Access	I/O allocation	Data attribute
1000	---	NX Bus Identity	---	---	---	---	---	---	---
	00	Number of Entries	7	7	---	USINT	RO	Not possible	---
	02	Model	*1	---	---	ARRAY[0..11] OF BYTE	RO	Not possible	---
	03	Device Type	*2	---	---	UDINT	RO	Not possible	---
	04	Product Code	*3	---	---	UDINT	RO	Not possible	---
	05	Vendor Code	00000001 hex*4	---	---	UDINT	RO	Not possible	---
	06	Unit Version	*5	---	---	UDINT	RO	Not possible	---
	07	Serial Number	*6	00000000 to FFFFFFFF hex	---	UDINT	RO	Not possible	---
1001	---	Production Info	---	---	---	---	---	---	---
	00	Number of Entries	4	4	---	USINT	RO	Not possible	---
	01	Lot Number	*7	00000000 to FFFFFFFF hex	---	UDINT	RO	Not possible	---
	02	Hardware Version	*8	---	---	ARRAY[0..19] OF BYTE	RO	Not possible	---
	03	Software Version	*8	---	---	ARRAY[0..19] OF BYTE	RO	Not possible	---

- *1. Product models are assigned in ascending order from the lowest number of array elements. Any remainder elements are filled with spaces.
- *2. The device types are assigned for each product Unit type.
Bits 0 to 31: Device type
- *3. The product codes are assigned for each product model.
Bits 0 to 31: Product code
- *4. OMRON vendor code.
- *5. Bits 24 to 31: Integer part of the unit version
Bits 16 to 23: Fractional part of the unit version
Bits 0 to 15: Reserved
(Example) For version 1.0: 0100□□□□ hex
- *6. A unique serial number is assigned for each product unit.
Bits 0 to 31: Serial number
- *7. The year, month, and day of production are assigned to the "lot number".
Bits 24 to 31: Date of production
Bits 16 to 23: Month of production
Bits 8 to 15: Year of production
Bits 0 to 7: Reserved

- *8. Version numbers are assigned in ascending order from the earliest number of array elements. Any remainder elements are filled with spaces.

A-5-3 Objects That Accept I/O Allocations

These objects accept I/O allocations.

You cannot access the objects that are described below with the Read NX Unit Object instruction, Write NX Unit Object instruction, or other messages.

Index (hex)	Subindex (hex)	Object name	Default value	Data range	Unit	Data type	Access	I/O allocation	Data attribute
6000	---	Analog Input Time Stamp	---	---	---	---	---	---	---
	00	Number of Entries	1	1	---	USINT	RO	Not possible	---
	01	Analog Input Time Stamp	0	0000000000 000000 to FFFFFFFF FFFFFFF hex	ns	ULINT	RO	Possible	---

- Refer to *Analog Input Time Stamp* on page 7-7 for details on the relevant data.

Index (hex)	Subindex (hex)	Object name	Default value	Data range	Unit	Data type	Access	I/O allocation	Data attribute
6001	---	Ch1 Input Data	---	---	---	---	---	---	---
	00	Number of Entries	67 hex	67 hex	---	USINT	RO	Not possible	---
	01	Ch1 Status	0000 hex	0000 to 0xFFFF hex	---	WORD	RO	Possible	---
	02	Ch1 Trigger Input Time Stamp	0	0000000000 000000 to FFFFFFFF FFFFFFF hex	ns	ULINT	RO	Possible	---
	03	Ch1 Number of Samplings	1	1, 2, 4, 5, 8, 10, 20, 25, 40, 50, 80, 100, 125, 200, 250, 400, 500, 625, or 1000	---	UINT	RO	Possible	---
	04	Ch1 Analog Input Value 1-10	0	---	---	AR- RAY[0..9] OF INT	RO	Possible	---
	05	Ch1 Analog Input Value 11-20	0	---	---	AR- RAY[0..9] OF INT	RO	Possible	---
	:	:	:	:	:	:	:	:	:
	67	Ch1 Analog Input Value 991-1000	0	---	---	AR- RAY[0..9] OF INT	RO	Possible	---

- Refer to the relevant data in 7-1-2 *Data Details* on page 7-6 for details on data.

Index (hex)	Subindex (hex)	Object name	Default value	Data range	Unit	Data type	Accesses	I/O allocation	Data attribute
6002	---	Ch2 Input Data	---	---	---	---	---	---	---
	00	Number of Entries	67 hex	67 hex	---	USINT	RO	Not possible	---
	01	Ch2 Status	0000 hex	0000 to 0xFFFF hex	---	WORD	RO	Possible	---
	02	Ch2 Trigger Input Time Stamp	0	0000000000 000000 to FFFFFFFF FFFFFFFF hex	ns	ULINT	RO	Possible	---
	03	Ch2 Number of Samplings	1	1, 2, 4, 5, 8, 10, 20, 25, 40, 50, 80, 100, 125, 200, 250, 400, 500, 625, or 1000	---	UINT	RO	Possible	---
	04	Ch2 Analog Input Value 1-10	0	---	---	AR-RAY[0..9] OF INT	RO	Possible	---
	05	Ch2 Analog Input Value 11-20	0	---	---	AR-RAY[0..9] OF INT	RO	Possible	---
	:	:	:	:	:	:	:	:	:
	67	Ch2 Analog Input Value 991-1000	0	---	---	AR-RAY[0..9] OF INT	RO	Possible	---

- Refer to the relevant data in *7-1-2 Data Details* on page 7-6 for details on data.

Index (hex)	Subindex (hex)	Object name	Default value	Data range	Unit	Data type	Access	I/O allocation	Data attribute
6003	---	Ch3 Input Data	---	---	---	---	---	---	---
	00	Number of Entries	67 hex	67 hex	---	USINT	RO	Not possible	---
	01	Ch3 Status	0000 hex	0000 to 0xFFFF hex	---	WORD	RO	Possible	---
	02	Ch3 Trigger Input Time Stamp	0	0000000000 000000 to FFFFFFFF FFFFFFF hex	ns	ULINT	RO	Possible	---
	03	Ch3 Number of Samplings	1	1, 2, 4, 5, 8, 10, 20, 25, 40, 50, 80, 100, 125, 200, 250, 400, 500, 625, or 1000	---	UINT	RO	Possible	---
	04	Ch3 Analog Input Value 1-10	0	---	---	AR- RAY[0..9] OF INT	RO	Possible	---
	05	Ch3 Analog Input Value 11-20	0	---	---	AR- RAY[0..9] OF INT	RO	Possible	---
	:	:	:	:	:	:	:	:	:
	67	Ch3 Analog Input Value 991-1000	0	---	---	AR- RAY[0..9] OF INT	RO	Possible	---

- Refer to the relevant data in 7-1-2 *Data Details* on page 7-6 for details on data.

Index (hex)	Subindex (hex)	Object name	Default value	Data range	Unit	Data type	Accesses	I/O allocation	Data attribute
6004	---	Ch4 Input Data	---	---	---	---	---	---	---
	00	Number of Entries	67 hex	67 hex	---	USINT	RO	Not possible	---
	01	Ch4 Status	0000 hex	0000 to 0xFFFF hex	---	WORD	RO	Possible	---
	02	Ch4 Trigger Input Time Stamp	0	0000000000 000000 to FFFFFFFF hex	ns	ULINT	RO	Possible	---
	03	Ch4 Number of Samplings	1	1, 2, 4, 5, 8, 10, 20, 25, 40, 50, 80, 100, 125, 200, 250, 400, 500, 625, or 1000	---	UINT	RO	Possible	---
	04	Ch4 Analog Input Value 1-10	0	---	---	AR-RAY[0..9] OF INT	RO	Possible	---
	05	Ch4 Analog Input Value 11-20	0	---	---	AR-RAY[0..9] OF INT	RO	Possible	---
	:	:	:	:	:	:	:	:	:
	67	Ch4 Analog Input Value 991-1000	0	---	---	AR-RAY[0..9] OF INT	RO	Possible	---

- Refer to the relevant data in 7-1-2 *Data Details* on page 7-6 for details on data.

Index (hex)	Subindex (hex)	Object name	Default value	Data range	Unit	Data type	Accesses	I/O allocation	Data attribute
7000	---	Ch1 Output Data	---	---	---	---	---	---	---
	00	Number of Entries	1	1	---	USINT	RO	Not possible	---
	01	Ch1 Operation Command	0000 hex	0000 to 0xFFFF hex	---	WORD	R/W	Possible	N

- Refer to *Ch□ Operation Command* on page 7-11 for details on the Ch□ Operation Command.

Index (hex)	Subindex (hex)	Object name	Default value	Data range	Unit	Data type	Access	I/O allocation	Data attribute
7001	---	Ch2 Output Data	---	---	---	---	---	---	---
	00	Number of Entries	1	1	---	USINT	RO	Not possible	---
	01	Ch2 Operation Command	0000 hex	0000 to 0xFFFF hex	---	WORD	R/W	Possible	N

- Refer to *Ch□ Operation Command* on page 7-11 for details on the Ch□ Operation Command.

Index (hex)	Subindex (hex)	Object name	Default value	Data range	Unit	Data type	Access	I/O allocation	Data attribute
7002	---	Ch3 Output Data	---	---	---	---	---	---	---
	00	Number of Entries	1	1	---	USINT	RO	Not possible	---
	01	Ch3 Operation Command	0000 hex	0000 to 0xFFFF hex	---	WORD	R/W	Possible	N

- Refer to *Ch□ Operation Command* on page 7-11 for details on the Ch□ Operation Command.

Index (hex)	Subindex (hex)	Object name	Default value	Data range	Unit	Data type	Access	I/O allocation	Data attribute
7003	---	Ch4 Output Data	---	---	---	---	---	---	---
	00	Number of Entries	1	1	---	USINT	RO	Not possible	---
	01	Ch4 Operation Command	0000 hex	0000 to 0xFFFF hex	---	WORD	R/W	Possible	N

- Refer to *Ch□ Operation Command* on page 7-11 for details on the Ch□ Operation Command.

A-5-4 Other Objects

This section lists other objects.

Index (hex)	Subindex (hex)	Object name	Default value	Data range	Unit	Data type	Accesses	I/O allocation	Data attribute
5002	---	Input Enable/Disable Setting	---	---	---	---	---	---	---
	00	Number of Entries	4	4	---	USINT	RO	Not possible	---
	01	Ch1 Enable/Disable	TRUE	TRUE or FALSE*1	---	BOOL	R/W	Not possible	Y
	02	Ch2 Enable/Disable	TRUE	TRUE or FALSE*1	---	BOOL	R/W	Not possible	Y
	03	Ch3 Enable/Disable	TRUE	TRUE or FALSE*1	---	BOOL	R/W	Not possible	Y
	04	Ch4 Enable/Disable	TRUE	TRUE or FALSE*1	---	BOOL	R/W	Not possible	Y

*1. The meanings of the set values for **Ch□ Enable/Disable** are as follows.

Set value	Meaning
FALSE	Disable
TRUE	Enable

- Refer to 8-2 *Selecting Channel To Use* on page 8-4 for details on the function.

Index (hex)	Subindex (hex)	Object name	Default value	Data range	Unit	Data type	Accesses	I/O allocation	Data attribute
5003	---	Input Range Setting	---	---	---	---	---	---	---
	00	Number of Entries	4	4	---	USINT	RO	Not possible	---
	01	Ch1 Range Setting	0	0 to 6*1	---	UINT	R/W	Not possible	Y
	02	Ch2 Range Setting	0	0 to 6*1	---	UINT	R/W	Not possible	Y
	03	Ch3 Range Setting	0	0 to 6*1	---	UINT	R/W	Not possible	Y
	04	Ch4 Range Setting	0	0 to 6*1	---	UINT	R/W	Not possible	Y

*1. The meanings of the set values for **Ch□ Range Setting** are as follows.

Set value	Meaning
0	-10 to 10 V
1	-5 to 5 V
2	0 to 10 V
3	0 to 5 V
4	1 to 5 V
5	0 to 20 mA
6	4 to 20 mA

- Refer to 8-3 *Input Range Selection* on page 8-6 for details on the function.

Index (hex)	Subindex (hex)	Object name	Default value	Data range	Unit	Data type	Access	I/O allocation	Data attribute
5004	---	Disconnection Detection Enable/Disable Setting	---	---	---	---	---	---	---
	00	Number of Entries	4	4	---	USINT	RO	Not possible	---
	01	Ch1 Disconnection Detection Enable/Disable	FALSE	TRUE or FALSE*1	---	BOOL	R/W	Not possible	N
	02	Ch2 Disconnection Detection Enable/Disable	FALSE	TRUE or FALSE*1	---	BOOL	R/W	Not possible	N
	03	Ch3 Disconnection Detection Enable/Disable	FALSE	TRUE or FALSE*1	---	BOOL	R/W	Not possible	N
	04	Ch4 Disconnection Detection Enable/Disable	FALSE	TRUE or FALSE*1	---	BOOL	R/W	Not possible	N

*1. The meanings of the set values for **Ch□ Disconnection Detection Enable/Disable** are as follows.

Set value	Meaning
FALSE	Disable
TRUE	Enable

- Refer to *8-6 Input Disconnection Detection* on page 8-29 for details on the function.

Index (hex)	Subindex (hex)	Object name	Default value	Data range	Unit	Data type	Accesses	I/O allocation	Data attribute
5005	---	Number of Samplings Setting	---	---	---	---	---	---	---
	00	Number of Entries	4	4	---	USINT	RO	Not possible	---
	01	Ch1 Number of Samplings Setting	1	1, 2, 4, 5, 8, 10, 20,	time s	UINT	R/W	Not possible	Y
	02	Ch2 Number of Samplings Setting	1	25, 40, 50, 80,	time s	UINT	R/W	Not possible	Y
	03	Ch3 Number of Samplings Setting	1	100, 125, 200, 250,	time s	UINT	R/W	Not possible	Y
	04	Ch4 Number of Samplings Setting	1	400, 500, 625, or 1000 *1	time s	UINT	R/W	Not possible	Y

*1. The meanings of the set values for **Ch□ Number of Samplings Setting** are as follows.

Set value	Meaning
1	1 time
2	2 times
4	4 times
5	5 times
8	8 times
10	10 times
20	20 times
25	25 times
40	40 times
50	50 times
80	80 times
100	100 times
125	125 times
200	200 times
250	250 times
400	400 times
500	500 times
625	625 times
1000	1000 times

- Refer to 8-4 *Number of Samplings Setting* on page 8-8 for details on the function.

Index (hex)	Subindex (hex)	Object name	Default value	Data range	Unit	Data type	Access	I/O allocation	Data attribute
5006	---	Digital Low-pass Filter Cutoff Frequency	---	---	---	---	---	---	---
	00	Number of Entries	4	4	---	USINT	RO	Not possible	---
	01	Ch1 Digital Low-pass Filter Cutoff Frequency	0	0 to 9900	× 10 Hz	UINT	R/W	Not possible	N
	02	Ch2 Digital Low-pass Filter Cutoff Frequency	0	0 to 9900	× 10 Hz	UINT	R/W	Not possible	N
	03	Ch3 Digital Low-pass Filter Cutoff Frequency	0	0 to 9900	× 10 Hz	UINT	R/W	Not possible	N
	04	Ch4 Digital Low-pass Filter Cutoff Frequency	0	0 to 9900	× 10 Hz	UINT	R/W	Not possible	N

- Refer to 8-5 *Digital Filtering* on page 8-18 for details on the function.

Index (hex)	Subindex (hex)	Object name	Default value	Data range	Unit	Data type	Access	I/O allocation	Data attribute
5007	---	Filter 1 Moving Average Count	---	---	---	---	---	---	---
	00	Number of Entries	4	4	---	USINT	RO	Not possible	---
	01	Ch1 Filter 1 Moving Average Count	0	0 to 4096	time s	UINT	R/W	Not possible	N
	02	Ch2 Filter 1 Moving Average Count	0	0 to 4096	time s	UINT	R/W	Not possible	N
	03	Ch3 Filter 1 Moving Average Count	0	0 to 4096	time s	UINT	R/W	Not possible	N
	04	Ch4 Filter 1 Moving Average Count	0	0 to 4096	time s	UINT	R/W	Not possible	N

- Refer to 8-5 *Digital Filtering* on page 8-18 for details on the function.

Index (hex)	Subindex (hex)	Object name	Default value	Data range	Unit	Data type	Access	I/O allocation	Data attribute
5008	---	Filter 2 Moving Average Count	---	---	---	---	---	---	---
	00	Number of Entries	4	4	---	USINT	RO	Not possible	---
	01	Ch1 Filter 2 Moving Average Count	0	0 to 4096	time s	UINT	R/W	Not possible	N
	02	Ch2 Filter 2 Moving Average Count	0	0 to 4096	time s	UINT	R/W	Not possible	N
	03	Ch3 Filter 2 Moving Average Count	0	0 to 4096	time s	UINT	R/W	Not possible	N
	04	Ch4 Filter 2 Moving Average Count	0	0 to 4096	time s	UINT	R/W	Not possible	N

- Refer to 8-5 *Digital Filtering* on page 8-18 for details on the function.

Index (hex)	Subindex (hex)	Object name	Default value	Data range	Unit	Data type	Access	I/O allocation	Data attribute
5009	---	Trigger Input Filter Setting	---	---	---	---	---	---	---
	00	Number of Entries	4	4	---	USINT	RO	Not possible	---
	01	Ch1 Input Filter Value Setting	4	0, or 3 to 9 ^{*1}	---	USINT	R/W	Not possible	N
	02	Ch2 Input Filter Value Setting	4	0, or 3 to 9 ^{*1}	---	USINT	R/W	Not possible	N
	03	Ch3 Input Filter Value Setting	4	0, or 3 to 9 ^{*1}	---	USINT	R/W	Not possible	N
	04	Ch4 Input Filter Value Setting	4	0, or 3 to 9 ^{*1}	---	USINT	R/W	Not possible	N

*1. The meanings of the set values for **Ch□ Input Filter Value Setting** are as follows.

Set value	Meaning
0	No Filter
3	4 μs
4	8 μs
5	16 μs
6	32 μs
7	64 μs
8	128 μs
9	256 μs

- Refer to 8-11 *Input Filter* on page 8-48 for details on the function.

A-6 Version Information with CPU Units

This section provides version-related information when connecting Units to a CPU Unit. This section describes the relationships between the unit versions of each Unit and the CPU Unit, and Sysmac Studio version, and the specification changes for each unit version of each Unit.

A-6-1 Relationship between Unit Versions of Units

The relationship between the unit versions of each Unit and the CPU Unit, and Sysmac Studio version are shown below.

Interpreting the Version Combination Table

The items that are used in the version combination table are given below.

Refer to the user's manual for the CPU Unit for the models of CPU Unit to which NX Units can be connected.

NX Unit		Corresponding unit versions/versions	
Model	Unit version	CPU Unit	Sysmac Studio
Model numbers of NX Units.	Unit versions of NX Units.	Unit versions of the CPU Unit that are compatible with the NX Units.	Sysmac Studio versions that are compatible with the NX Units and CPU Unit.

Version Combination Table

- With the combinations of the unit versions/versions shown below, you can use the functions that are supported by the unit version of the Unit model. Use the unit versions/versions (or the later/higher unit versions/versions) that correspond to the NX Unit models and the unit versions. You cannot use the specifications that were added or changed for the relevant NX Unit models and the unit versions unless you use the corresponding unit versions/versions.
- Depending on the type and model of the Unit to which the NX Unit is connected, some Units do not have the corresponding versions given in the table. If a Unit does not have the specified version, support is provided by the oldest available version after the specified version. Refer to the user's manuals for the specific Units for the relation between models and versions.
- If you use the corresponding unit versions/versions given in the following table or later/higher versions, refer to the version information in the user's manual for the CPU Unit.

NX Unit		Corresponding unit versions/versions	
Model	Unit version	CPU Unit	Sysmac Studio
NX-HAD401	Ver.1.0	Ver. 1.18	Ver.1.23
NX-HAD402			

A-7 Version Information with Communications Coupler Units

This section provides version-related information when connecting Units to a Communications Coupler Unit. The High-speed Analog Input Units can be connected only to an EtherCAT Coupler Unit.

A-7-1 Connection to an EtherCAT Coupler Unit

This section describes the relationship between the unit versions of each Unit, EtherCAT Coupler Unit, CPU Unit and Industrial PC, versions of the Sysmac Studio, and the specification changes for each unit version.

Relationship between Unit Versions of Units

The items that are used in the version combination table are given below.

NX Unit		Corresponding unit versions/versions		
Model	Unit version	EtherCAT Coupler Unit	CPU Unit or Industrial PC	Sysmac Studio
Model numbers of NX Units.	Unit versions of NX Units.	Unit versions of EtherCAT Coupler Units that are compatible with the NX Units.	Unit versions of NJ/NX-series CPU Units or NY-series Industrial PCs that are compatible with the EtherCAT Coupler Units.	Sysmac Studio versions that are compatible with the NX Units, EtherCAT Coupler Units, CPU Units, and Industrial PCs.

The version combination table is given below.

- With the combinations of the unit versions/versions shown below, you can use the functions that are supported by the unit version of the Unit model. Use the unit versions/versions (or the later/higher unit versions/versions) that correspond to the NX Unit models and the unit versions. You cannot use the specifications that were added or changed for the relevant NX Unit models and the unit versions unless you use the corresponding unit versions/versions.
- Depending on the type and model of the Unit to which the NX Unit is connected, some Units do not have the corresponding versions given in the table. If a Unit does not have the specified version, support is provided by the oldest available version after the specified version. Refer to the user's manuals for the specific Units for the relation between models and versions.
- You cannot connect the relevant NX Unit to the target Communications Coupler Unit if "---" is shown in the corresponding unit versions/versions column.
- If you use the corresponding unit versions/versions given in the following table or later/higher versions, refer to the version information in the user's manual for the Communications Coupler Unit, CPU Unit, and Industrial PC.

NX Unit		Corresponding unit versions/versions		
Model	Unit version	EtherCAT Coupler Unit	CPU Unit or Industrial PC	Sysmac Studio
NX-HAD401	Ver.1.0	Ver.1.0	Ver. 1.18	Ver.1.23
NX-HAD402				

A

A-8 Displaying the Edit Unit Operation Settings Tab Page

A-8-1 Connection to the CPU Unit

This section describes how to display the Edit Unit Operation Settings Tab Page when you edit Unit operation settings on the Sysmac Studio for NX Units connected to the CPU Unit.

You can use the methods described below to display the Edit Unit Operation Settings Tab Page via the CPU and Expansion Racks Tab Page on the Sysmac Studio.

Refer to the *Sysmac Studio Version 1 Operation Manual (Cat. No. W504)* for the method of displaying the CPU and Expansion Racks Tab Page.

● Method 1

Double-click the NX Unit to set.

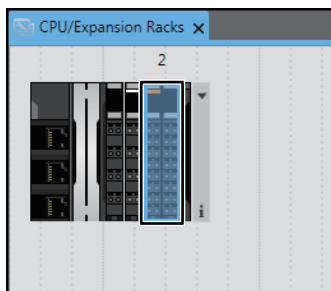

● Method 2

Right-click the NX Unit and select **Edit Unit Operation Settings** from the menu.

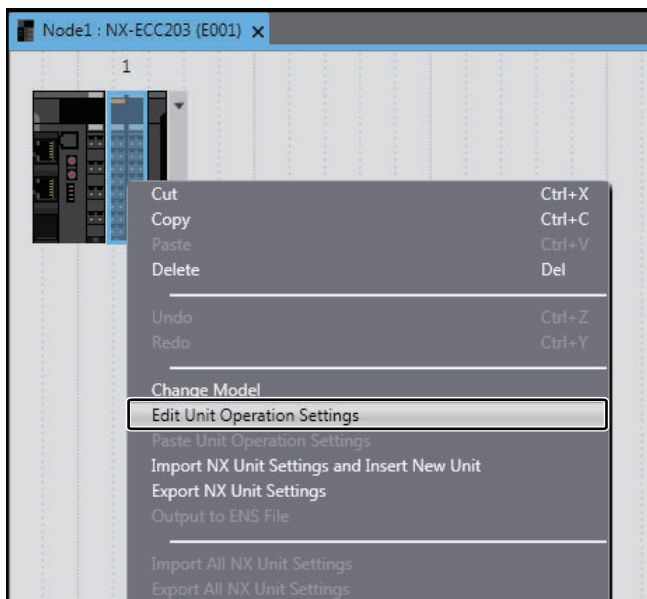

● Method 3

Select the NX Unit and click the **Edit Unit Operation Settings** Button.

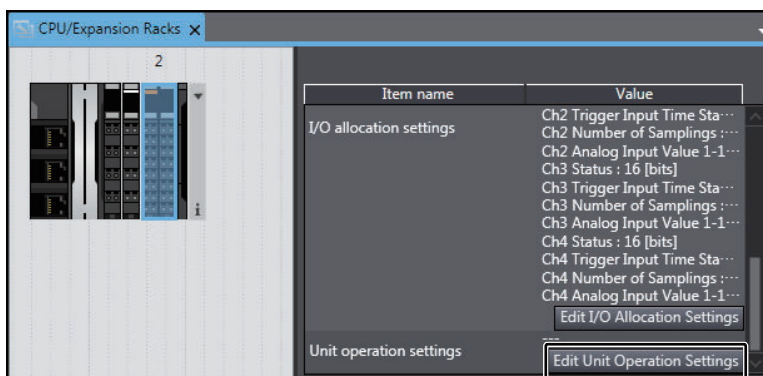

A-8-2 Slave Terminal

This section describes how to display the Edit Unit Operation Settings Tab Page when you edit Unit operation settings on the Sysmac Studio for NX Units configured as a Slave Terminal. You can use the methods described below to display the Edit Unit Operation Settings Tab Page via the Edit Slave Terminal Configuration Tab Page on the Sysmac Studio. Refer to the *Sysmac Studio Version 1 Operation Manual (Cat. No. W504)* for how to display the Edit Slave Terminal Configuration Tab Page.

● Method 1

Double-click the NX Unit to set.

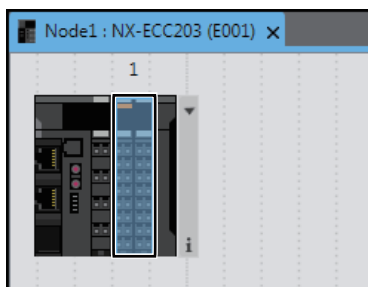

● Method 2

Right-click the NX Unit and select **Edit Unit Operation Settings** from the menu.

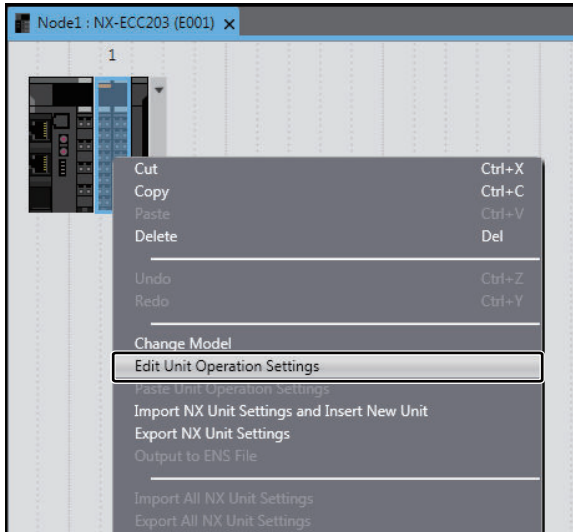

● **Method 3**

Select the NX Unit and click the **Edit Unit Operation Settings** Button.

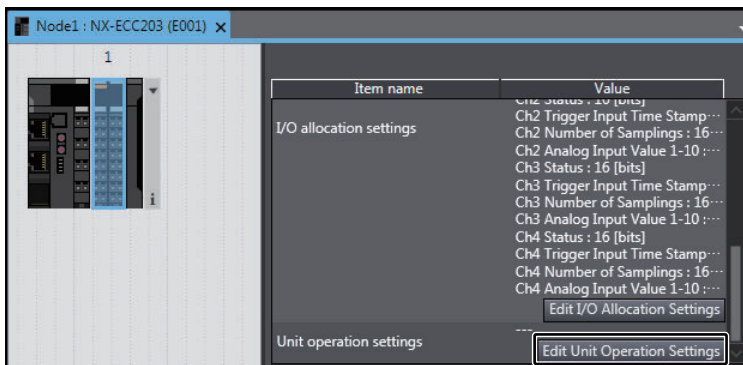

A-9 Edit Unit Operation Settings Tab Page

The following screen capture shows the Edit Unit Operation Settings Tab Page on the Sysmac Studio.

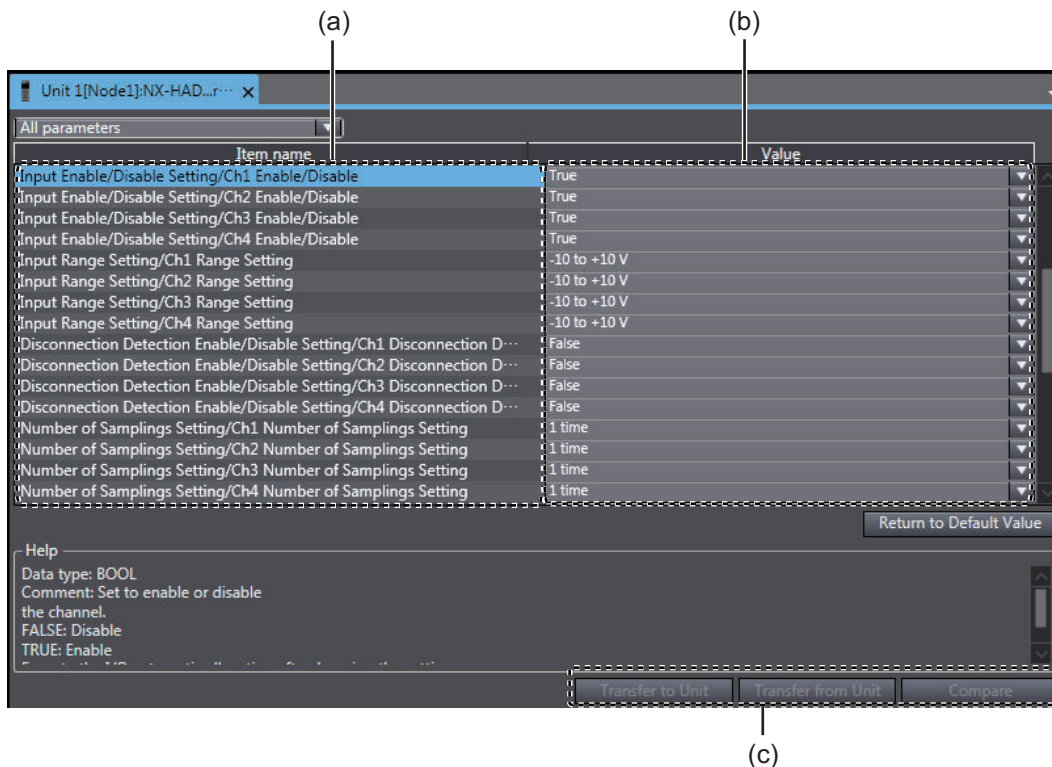

Letter	Description
(a)	Unit operation settings.
(b)	Set values of the Unit operation settings. For each setting, select a set value from the list, or enter a set value in the text box.
(c)	Transfer Buttons and Compare Button. Click the Transfer to Unit Button to transfer the Unit operation settings from the Sysmac Studio to the NX Unit.



Additional Information

- Click a list button below the tab to select specific operation settings to display in the Edit Unit Operation Settings Tab Page. The following screen captures show an example of displaying only the Input Enable/Disable Setting under Ch1.

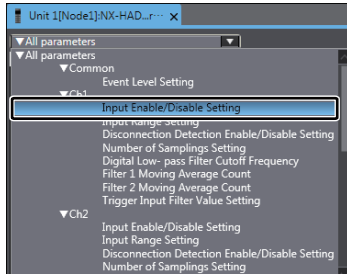

Select Input Enable/Disable Setting under Ch1

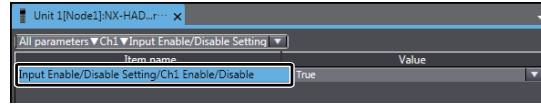

Only Input Enable/Disable Setting under Ch1 is displayed

- If you set a value different from the default value, the **Value** on the Sysmac Studio is displayed in a different color.
- You can click the **Return to Default Value** Button to return all the set values on the Sysmac Studio to the default values.
- Help for the settings is displayed at the bottom of the Edit Unit Operation Settings Tab Page.

A-10 Displaying the User Calibration Window

A-10-1 Connection to the CPU Unit

This section describes how to display the Sysmac Studio User Calibration Window for a High-speed Analog Input Unit connected to the CPU Unit.

- 1 In the Multiview Explorer, double-click the CPU Rack to which the target High-speed Analog Input Unit is connected to open the CPU and Expansion Racks Tab Page. The following tab page is displayed.

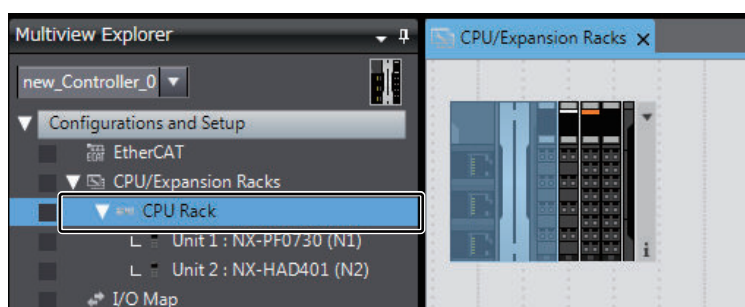

- 2 Go online, right-click the High-speed Analog Input Unit on the CPU and Expansion Racks Tab Page, and select **User Calibration** from the menu.

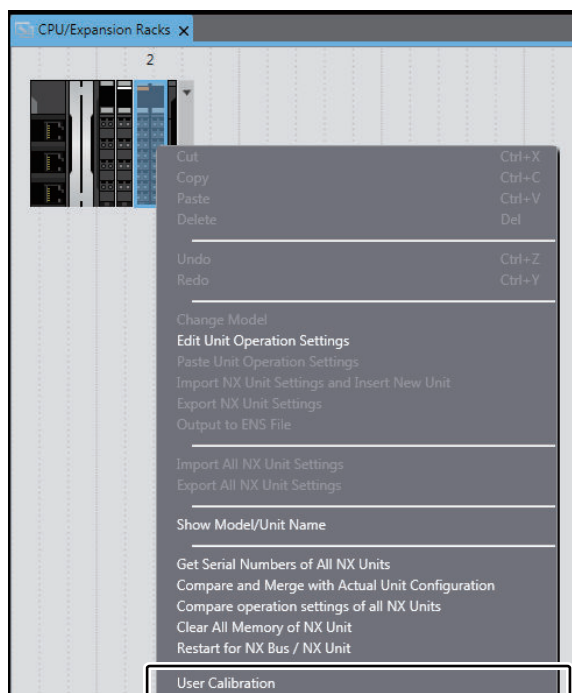

The following window is displayed.

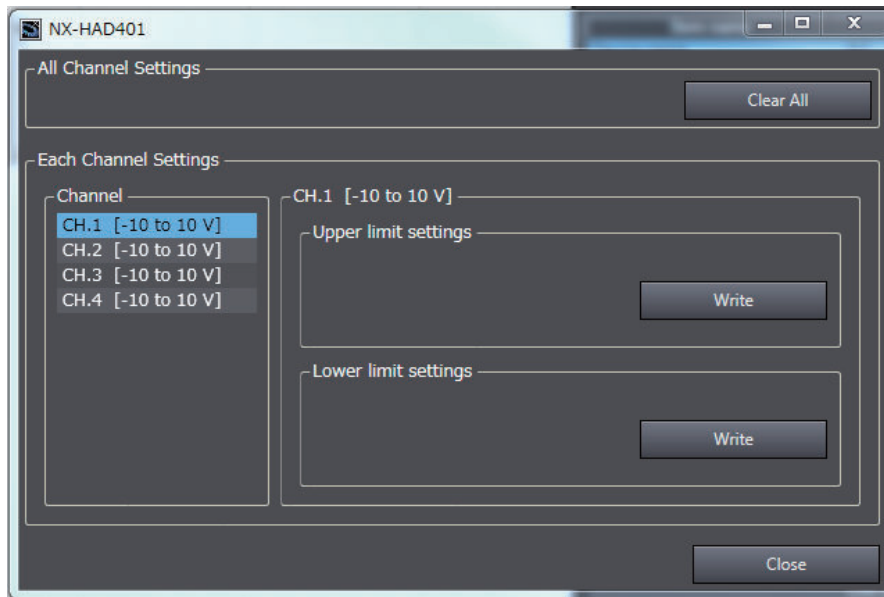

A-10-2 Slave Terminal

This section describes how to display the Support Software User Calibration Window for a High-speed Analog Input Unit connected to the Communications Coupler Unit.

- 1 In the Multiview Explorer, double-click the Communications Coupler Unit to which the target High-speed Analog Input Unit is connected to open the Edit Slave Terminal Configuration Tab Page.

The following tab page is displayed.

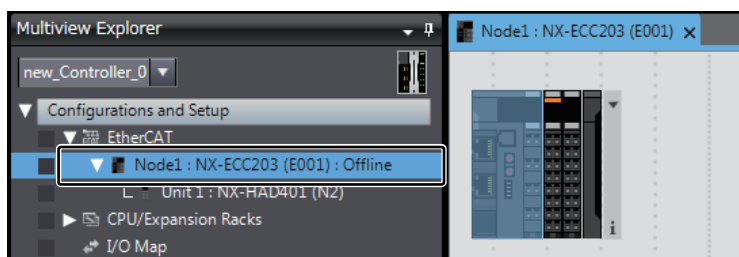

- 2 Go online, right-click the High-speed Analog Input Unit on the Edit Slave Terminal Configuration Tab Page, and select **User Calibration** from the menu.

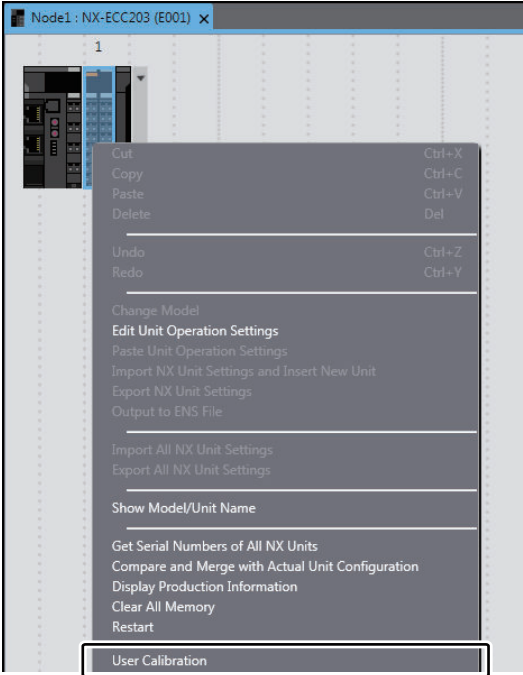

The following window is displayed.

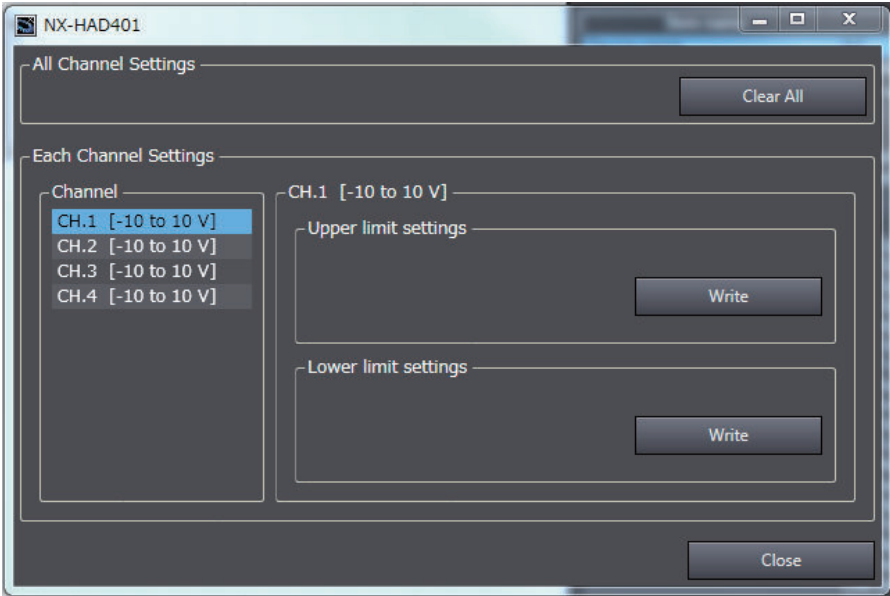



Index



Index

A	
Access.....	A-38
Additional I/O Power Supply Units.....	4-5
Additional NX Unit Power Supply Units.....	4-5
angle for insertion.....	4-11, 4-14
Applicable Wire.....	4-7
B	
built-in EtherCAT port.....	6
C	
Coding Pin.....	4-18
Communications Coupler Unit.....	1-6
Communications Master Unit.....	5-3
CPU Rack.....	1-6
CPU Unit.....	5-3
crimping tool.....	4-8
Current Error.....	9-5
D	
Data attribute.....	A-38
Data range.....	A-38
Data type.....	A-38
DC enable.....	5-7
Default value.....	A-38
Digital filter processing frequency.....	8-16
Digital Filter Processing Period.....	8-19
Digital Low-pass Filter.....	8-20
DIN Track mounting hook.....	3-2
F	
Ferrule.....	4-8
G	
Ground terminal.....	4-8, 4-9
I	
I/O allocation.....	A-38
I/O entry.....	7-2
I/O power supply.....	4-4
I/O Power Supply Connection Units.....	4-5
I/O power supply terminal.....	4-4
incorrect attachment prevention hole.....	4-20
Index.....	A-38
Indicator.....	3-2
Industrial PC.....	5
L	
Log of Error.....	9-5
M	
Marker attachment location.....	3-2
maximum I/O power supply current.....	4-5
Model number indication.....	3-3
Moving Average Filter.....	8-23
N	
NX bus connector.....	3-2
NX Object.....	A-38
NX Unit power supply.....	4-4
O	
Object name.....	A-38
Objects that accept I/O allocations.....	A-40
Other Objects.....	A-45
P	
Periodic Inspection Item.....	10-2
Preventing Incorrect Attachment.....	4-17
Protrusions for removing the Unit.....	3-2
R	
refresh cycle of the NX bus.....	5-2, 5-3
Release hole.....	3-6
S	
Sampling frequency.....	7-17
sampling operation.....	5-9
sampling period.....	8-8
Securing Wires.....	4-13
Slave Terminal.....	1-6
Solid Wire.....	4-9
Subindex.....	A-38
Supply from the NX bus.....	4-4
T	
Terminal block.....	3-2, 3-6
Terminal hole.....	3-6
Terminal number indication.....	3-6
Twisted Wire.....	4-9
U	
Unit.....	A-38
Unit hookup guide.....	3-2
Unit Information Object.....	A-38
Unit specifications.....	3-2
Update timing.....	7-20

W

Wiring Terminal..... 4-7

OMRON Corporation Industrial Automation Company

Kyoto, JAPAN

Contact : www.ia.omron.com

Regional Headquarters

OMRON EUROPE B.V.

Wegalaan 67-69, 2132 JD Hoofddorp
The Netherlands
Tel: (31) 2356-81-300 Fax: (31) 2356-81-388

OMRON ELECTRONICS LLC

2895 Greenspoint Parkway, Suite 200
Hoffman Estates, IL 60169 U.S.A.
Tel: (1) 847-843-7900 Fax: (1) 847-843-7787

OMRON ASIA PACIFIC PTE. LTD.

438B Alexandra Road, #08-01/02 Alexandra
Technopark, Singapore 119968
Tel: (65) 6835-3011 Fax: (65) 6835-3011

OMRON (CHINA) CO., LTD.

Room 2211, Bank of China Tower,
200 Yin Cheng Zhong Road,
PuDong New Area, Shanghai, 200120, China
Tel: (86) 21-6023-0333 Fax: (86) 21-5037-2388

Authorized Distributor:

©OMRON Corporation 2018-2025 All Rights Reserved.
In the interest of product improvement,
specifications are subject to change without notice.

Cat. No. W592-E1-04 1025